

DALBO®

**Reservedele
Spareparts
Ersatzteile
Pieces**

**MINIMAX 950 CB
(22930-7, 22925-7, 22933, 22931, 22932)
Serie no. 109960 - 111379**

MADE IN  DENMARK

RESERVEDELSLISTENS OPBYGNING, THE CONSTRUCTION OF THE SPAREPARTSLIST	5
MINIMAX 950 UDEN GODS/AKSLER/HYDRAULIK	6
NAV FOR 950 KPL. MONROC Ø60/A450, NABE, HUB, MOYEU	8
GODS PÅ AKSEL CROSKILL 53CM, METAL ON SHAFT, GIESSGUT AUF WELLEN, METAL SUR ARBRES	10
GODS PÅ AKSEL CAMBRIDGE SNOWFLAKE 50, METAL ON SHAFT, GIESSGUT AUF WELLEN, METAL SUR ARBRES.....	12
GODS PÅ AKSEL CROSS COMBI 50, METAL ON SHAFT, GIESSGUT AUF WELLEN, METAL SUR ARBRES	16
GODS PÅ AKSEL CROSS COMBI 55, METAL ON SHAFT, GIESSGUT AUF WELLEN, METAL SUR ARBRES	17
HYDRAULIK VIPPECYLINDER HOVEDDRAMME, HYDRAULIC MAIN FRAME, HYDRAULIK HAUPTTRAHMEN, CHASSIS HYDAULIQUE	18
HYDRAULIK SAMMENKLAP, HYDRAULIC FOLDING, HYDRAULIK AUS/ZUSAMMENKLAPPEN, HYDAULIQUE DE REPLIAGE	20
EKSTRAUDSTYR, OPTIONS, ZUSATZAUSRÜSTUNG, ACCESSOIRES EN OPTION	22
LYS, LIGHT SET, BELEUCHTUNGSANLAGE, ENSEMBLE DE PHARES	22
CRACKERBOARD 950	24
LAMELTAND KPL. MED BRED SLIDDEL. CRACKERBORD TINE. CB – ZINKEN. DENT CB.....	26
HYDRAULIK FOR LAMELPLANKE, HYDRAULIK CRACKERBOARD, HYDRAULIC CRACKERBOARD, CRACKERBOARD HYDRAULIQUE.....	28
STENKASSE 100 L MED BESLAG, STEINKISTE, STONE BOX, BOITE A PIERRES	30
LIFTRÆK KAT. 3, ZUG, DRAWBAR, ATTELAGE.....	32

Reservedelslistens opbygning, the construction of the sparepartslist

<p>Reservedelstegningerne tager udgangspunkt i en MINIMAX 830. Ved de øvrige modeller er der udarbejdet en ekstra reservedelsliste hvor i forskellene som hoveddrammer mm. fremgår</p>	<p>The spare parts drawings have there point of origin in a MINIMAX 830. For the other models there is made an extra spare parts list, where the differences is shown.</p>	<p>Die Ersatzteilzeichnungen sind ursprünglich von der MINIMAX 830. Für die anderen Typen gibt es eine separate Ersatzteilliste, die Unterschiede aufzeigt.</p>	<p>Les dessins des pièces détachées sont basés sur un MINIMAX 830. Pour les autres modèles une liste supplémentaire de pièces est établie où les différences sont montrées.</p>
<p>For deres sikkerhed samt for funktionsdygtigheden af deres maskine, bør der kun anvendes originale DALBO reservedele til deres maskine</p> <p>Når de bestiller reservedele bør de altid informere om:</p> <ul style="list-style-type: none"> • Reservedelsnummer • Maskinens typenummer • Antal styk af reservedelen 	<p>For your safety and for the functions of the mashing, you should only use original spare parts for m DALBO.</p> <p>When you order spare parts, you should always inform about:</p> <ul style="list-style-type: none"> • Spare part number • The mashing type number • Amount of spare parts pieces 	<p>Zu Ihrer Sicherheit und zur einwandfreien Funktion ihres Gerätes sollten sie unbedingt nur original DALBO Ersatzteile verwenden.</p> <p>Wenn sie Ersatzteile bestellen bitte folgendes beachten:</p> <ul style="list-style-type: none"> • Ersatzteil-Nummer • Geräte-Nummer und -typ • Anzahl der Ersatzteile 	<p>Pour votre sécurité et pour les fonctions du matériel, vous devez utiliser uniquement des pièces détachées d'origine DALBO.</p> <p>Lorsque vous commandez vos pièces détachées, vous devez toujours nous indiquer :</p> <ul style="list-style-type: none"> • Le numéro de la pièce • Le type de la machine • La quantité des pièces détachées.

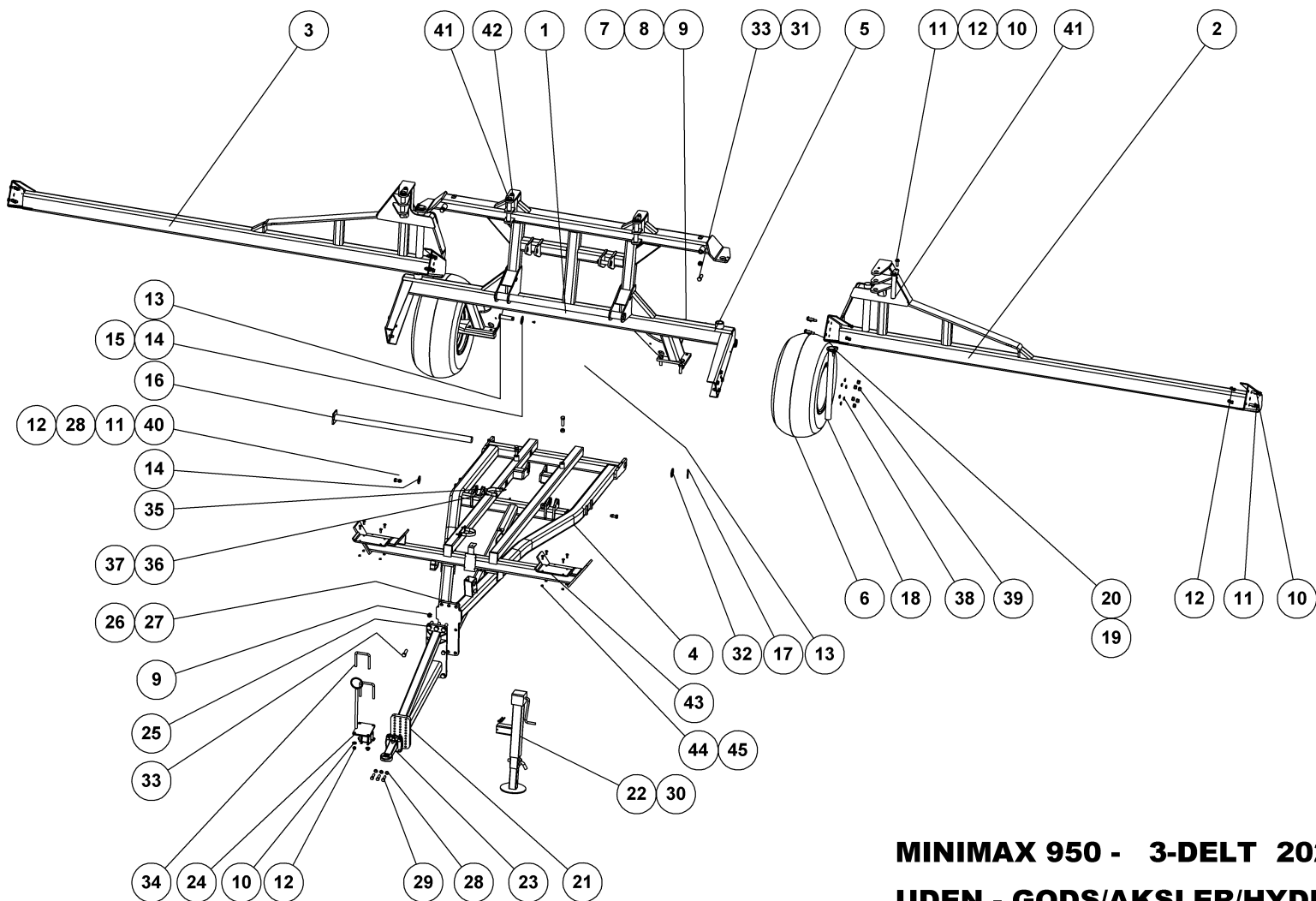

MINIMAX 950 - 3-DELT 2022
UDEN - GODS/AKSLER/HYDRAULIK

24965



MINIMAX 950 - 3-DELT 2022

UDEN - GODS/AKSLER/HYDRAULIK

24965

Pos.	Qty.	Part nr.	Benævnelse	Bezeichnung	Description	Designation
1	1	24890	MIDTERSEKTION - MINIMAX 950 - 2022	MITTLERE SEKTION	MIDDLE SECTION	SECTION CENTRALE
2	1	24893	MINIMAX 950 SÍDESEKTION - 2022	SEITENRAHMEN LINKS	SIDE FRAME, LEFT	CADRE LATÉRAL GAUCHE
3	1	24892	MINIMAX 950 SÍDESEKTION - 2022	SEITENRAHMEN RECHTS	SIDE FRAME, RIGHT	CADRE LATÉRAL DROITE
4	1	24891	TRÆK MINIMAX 950 - 3 DELT - 2022	ZUG JUBI HINTEN	DRAWBAR	ATTELAGE DE DERRIÈRE
5	2	67220	NAV MED FLANGE	NABE	HUB	MOYEU
6	2	25259	HJUL KPL. 400/60-15,5 14 PLY	RAD	WHEEL	ROUE
7	6	92342	BOLT M20X70 MM 8.8 GALV.	SCHRAUBE	SCREW	BOULON
8	6	90671	SKIVE Ø21-Ø37-3	UNTERLEGSSCHEIBE	WASHER	RONDELLE DE SERRAGE
9	6	92052	MØTRIK M20, SELVLÅS, GALV. KV. 8.8	MUTTER SELBSTGESICHERT	SELF-LOCKING NUT	ÉCROU DE SÉCURITÉ
10	32	90663	SKIVE Ø17/Ø35X2 MM	SCHEIBE	WASHER	RONDELLE
11	28	92317	BOLT 16X50 MM 8.8 GALV.	SCHRAUBE	SCREW	BOULON
12	32	92051	MØTRIK M16, SELVLÅS, GALV. KV. 8.8	MUTTER	NUT	ÉCROU
13	2	20263	NAGLE R Ø30X105(120)	BOLZEN	PIN	AXE
14	10	90660	SKIVE Ø33-Ø68-4	UNTERLEGSSCHEIBE	WASHER	RONDELLE DE SERRAGE
15	2	90677	SPLIT 8X50 MM GALV.	SPLINT	SPLIT PIN	GOUPILLE
16	1	23297	NAGLE F Ø50 X 1210 (1241)	BOLZEN	PIN	AXE
17	1	90684	SPLIT Ø8X60 MM	SPLINTE	SPLIT PIN	GOUPILLE
18	2	23294	NAGLE F Ø50X665(678) SPEC.T/SIDES.	BOLZEN	PIN	AXE
19	4	90669	SKIVE Ø13-Ø24-2,5	UNTERLEGSSCHEIBE	WASHER	RONDELLE DE SERRAGE
20	4	92295	BOLT 12x30 8.8 GALV. (SÆTBOLT)	SCHRAUBE	SET SCREW	BOULON
21	1	23273	TRÆK 930CM VENDBAR FOR	ZUG VERLÄNGERUNG	DRAWBAR EXTENSION	ALLONGEMENT D'ATTELAGE
22	1	23515	STØTTEBEN MINIMAX 830 2008	STÜTZFUSS	JACK	BÉQUILLE
23	1	25240	SCHARMÜLLER Ø40 MM - 2500 KG	ZUG	DRAWBAR EYE	CROCHET D'ATTELAGE
24	1	23393	HOLDER FOR STØTTEBEN	STÜTZFUSSBEFESTIGUNG	JACK BRACKET	FIXATION DE BÉQUILLE
25	6	92351	BOLT 24x80 8.8 GALV.	SCHRAUBE	SCREW	BOULON
26	6	90670	SKIVE Ø25-Ø44-4	UNTERLEGSSCHEIBE	WASHER	RONDELLE DE SERRAGE
27	6	92053	MØTRIK M24, SELVLÅS, GALV. KV. 8.8	MUTTER	SELF-LOCKING NUT	ÉCROU
28	8	90643	SKIVE Ø17/Ø29X3 MM	SCHEIBE	WASHER	RONDELLE
29	6	92314	BOLT 16X55 MM 8.8 GALV.	SCHRAUBE	SCREW	BOULON
30	1	90645	HÄRNÄL Ø6 X 114	SPLINT	HAIRPIN	GOUPILLE
31	4	92032	MØTRIK M20, GALV. KV. 8.8	MUTTER	NUT	ÉCROU
32	1	51349	SKIVE Ø51-Ø75-3 Giv	SCHEIBE	WASHER	RONDELLE
33	4	92343	BOLT 20x70 8.8 GALV. (SÆTBOLT)	BOLZEN	SET SCREW	BOULON
34	2	14202	BØJLE TIL HARVESÆT	SCHRAUBE	SCREW	BOULON
35	2	37543	BØJLE FOR AKKUMULATOR	HALTER	BRACKET	SUPPORT
36	4	91307	BOLT M8X35, M/SKAFT GALV. KV. 8.8	SCHRAUBE FÜR SCHLAUCHHALTER	HOSE CLAMP SCREW	BOULON POUR SUPPORT TUYAU
37	5	92048	MØTRIK M8, SELVLÅS, GALV. KV. 8.8	MUTTER	NUT	ÉCROU
38	12	33283	FJEDERSKIVE FZB M18	SCHEIBE	WASHER	RONDELLE
39	12	33282	NAV MØTRIK 10 FZG M18X1,5	MUTTER	NUT	ÉCROU
40	2	26841	NAGLE Ø30 95MM M16	BOLZEN	PIN	AXE
41	4	69137	NAGLE Ø35 X 225	BOLZEN	PIN	AXE
42	2	92315	BOLT 16X30 MM 8.8 GALV.	SCHRAUBE	SCREW	BOULON
43	2	24836	STØDPLADE TIL GODSBERER	GUMMIKLÖTZ	RUBBER BLOCK	BLOC EN CAOUTCHOUC
44	8	92029	MØTRIK M10, GALV. KV. 8.8	MUTTER	NUT	ÉCROU
45	8	92381	BOLT M10X30, BRÆDEBOLT GALV. KV. 8.8	SCHRAUBE	BOARD BOLT	BOULON

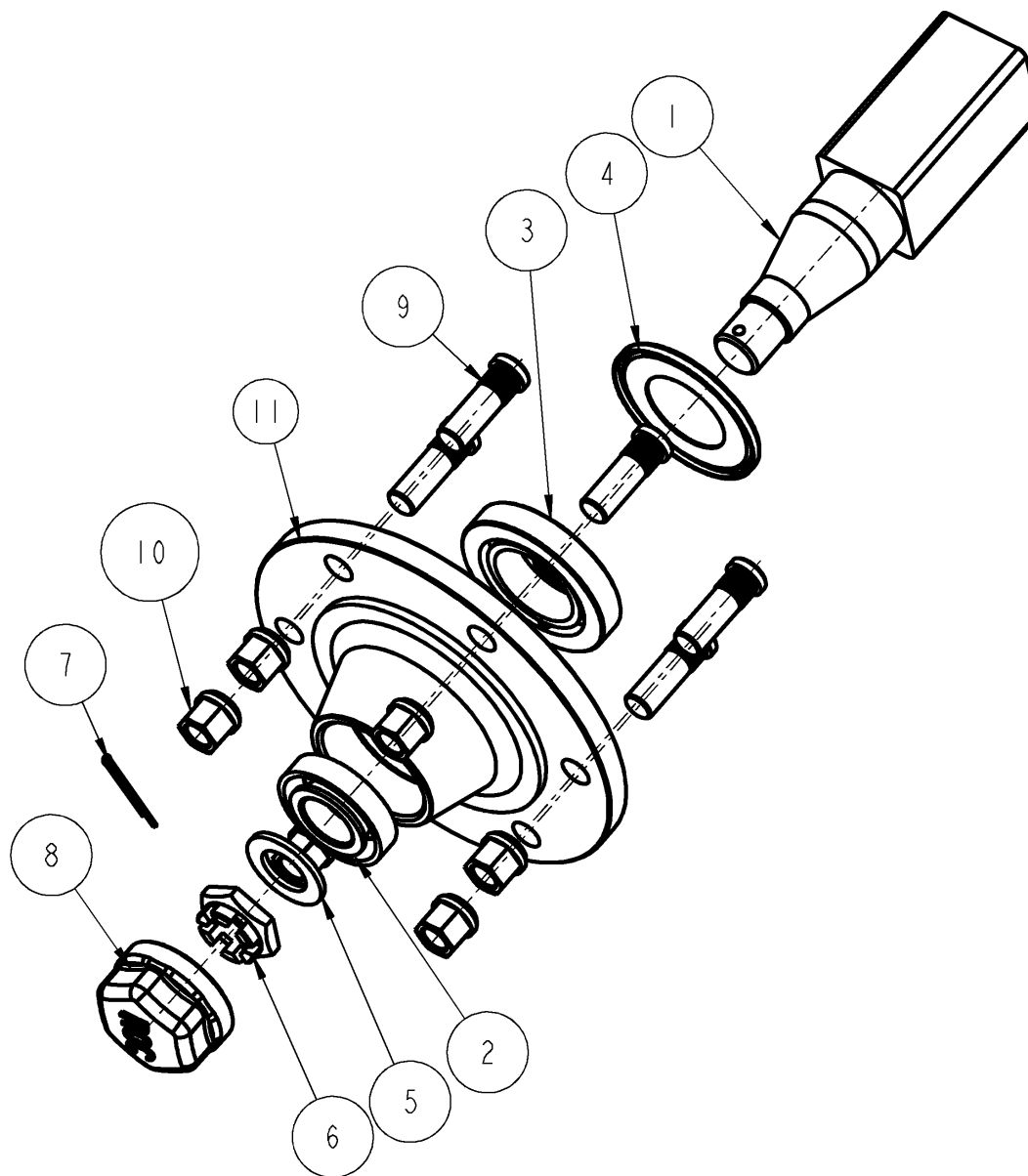

33207

Pos.	Qty.	Part nr.	Benævnelse	Bezeichnung	Description	Designation
1	1	33210	AKSEL	WELLE	SHAFT	ARBRE
2	1	12849	LEJE 30207	LAGER	BEARING	FIXATION
3	1	12863	LEJE 30211	LAGER	BEARING	FIXATION
4	1	33211	TÆTNINGSRING	DICHTUNGSRING	SEAL	BAGUE D'ÉTANCHEITE
5	1	33212	SKIVE 31X52X4	SCHEIBE	WASHER	RONDELLE DE SERRAGE
6	1	33213	KRONEMØTRIK	ACHSENMUTTER	SHAFT NUT	ECROU D'ARBRE
7	1	33214	SPLIT	SPLINTE	SPLIT PIN	GOUPILLE
8	1	33215	NAVKAPSEL	NABEKAPSEL	HUB CAP	BOITE DE MOYEU
9	6	23452	NAV Bolt M18X1,5 – 40/54	SCHRAUBE	SCREW	BOULON
10	6	23453	NAVMØTRIK M18	MUTTER	NUT	ECROU

Gods på aksel Croskill 53cm, Metal on shaft, Giessgut auf Wellen, Metal sur arbres

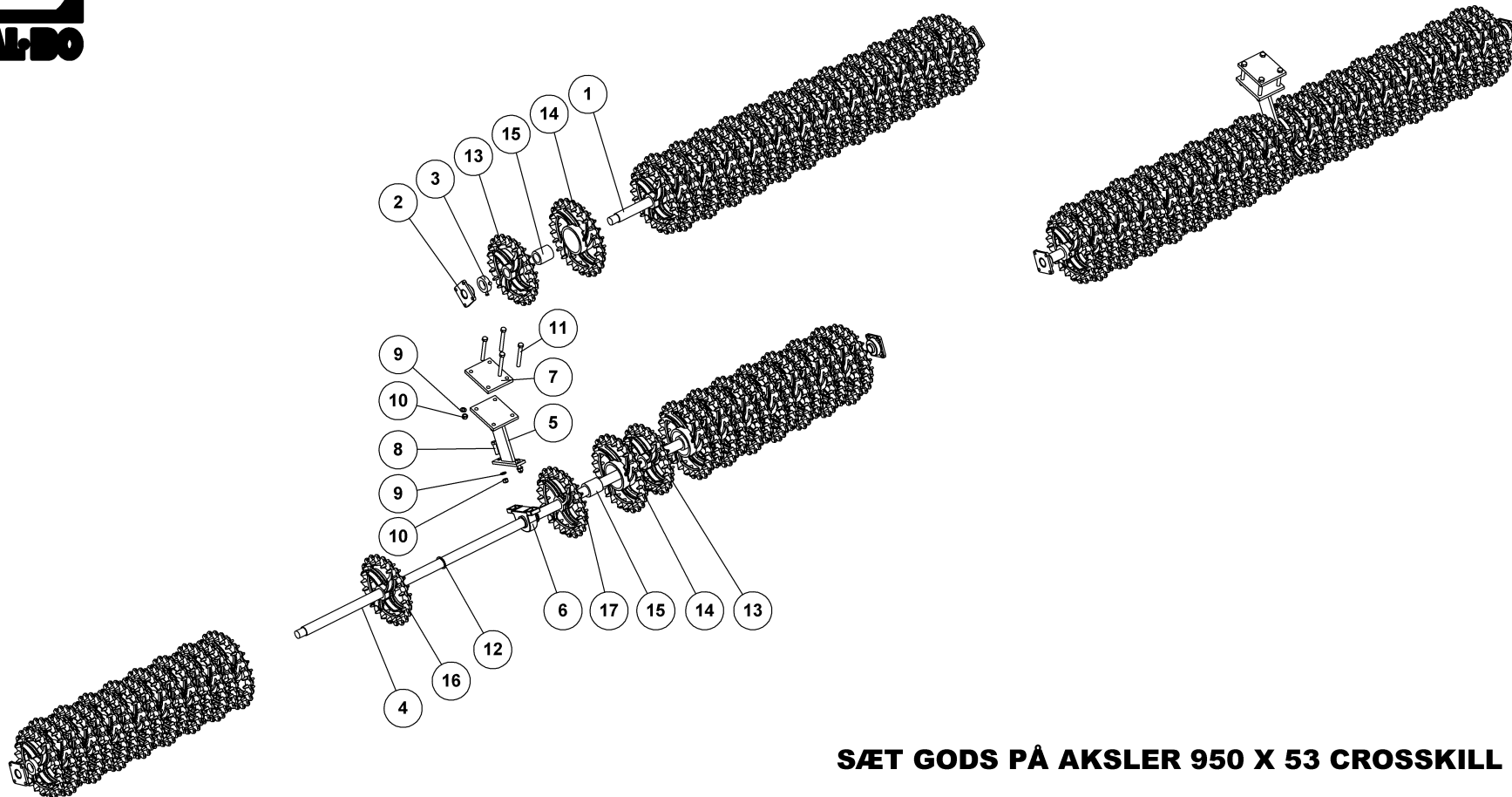

SÆT GODS PÅ AKSLER 950 X 53 CROSSKILL

22937



SÆT GODS PÅ AKSLER 950 X 53 CROSSKILL

22937

Pos.	Qty.	Part nr.	Benævnelse	Bezeichnung	Description	Designation
1	1	23386	AKSEL Ø60X2940	WELLE	SHAFT	ARBRE
2	6	12457	FLANGELEJE Ø50 SKF FY 50 TR	KOMPLETTES Y-LAGER	COMPLETE Y-BEARING	PALIER-Y COMPLET
3	6	12334	STOPRING Ø 60 KPL.	ANSCHLAGRING	STOP BUSHING	BAGUE D'ARRÊT
4	2	22924	AKSEL Ø60X3750 - MINIMAX 950 SIDE	WELLE	SHAFT	ARBRE
5	2	22928	STØTTE FOR MIDTERLEJE	STÜTZE	SUPPORT	FIXATION
6	2	12459	KOMPLET STÅLEJE Ø60 MM - SKF SYJ65KF+H2313.	KOMPLETTES STEH LAGER	COMPLETE STEEL BEARING	PALIER COMPLET
7	2	37986	FLANGEPLADE TIL STØTTELEJE	FLANSCHEN	FLANGE	AILE
8	4	92342	BOLT M20X70 MM 8.8 GALV.	SCHRAUBE	SCREW	BOULON
9	12	90671	SKIVE Ø21-Ø37-3	UNTERLEGSSCHEIBE	WASHER	RONDELLE DE SERRAGE
10	12	92052	MØTRIK M20 SELVLÅS GALV. KV. 8.8	MUTTER SELBSTGESICHERT	SELF-LOCKING NUT	ÉCROU DE SÉCURITÉ
11	8	92604	BOLT 20x170 8.8 GALV.	SCHRAUBE	SCREW	BOULON
12	6	93130000590L90L	EMNERØR 80X63 ISO2938 ST			
13	46	18101	CROSSKILL RING Ø480/62	CROSSKILL RING	CROSSKILL RING	ANNEAU CROSSKILL
14	45	18102	CROSSKILL RING Ø530/160	ZYLINDER	CROSSKILL RING	ANNEAU CROSSKILL
15	45	18103	CROSSKILL BØSNING Ø90/62	CROSSKILL BUCHSE	CROSSKILL BUSHING	DOUILLE CROSSKILL
16	2	18109	CROSSKILL Ø480 - SMAL VENSTRE	CROSSKILL SCHMAL LINKS	CROSSKILL, NARROW LEFT	CROSSKILL - ÉTROIT GAUCHE
17	2	18108	CROSSKILL Ø480 - SMAL HØJRE	CROSSKILL SCHMAL RECHTS	CROSSKILL, NARROW RIGHT	CROSSKILL - ÉTROIT DROITE

Gods på aksel Cambridge Snowflake 50, Metal on shaft , Giessgut auf Wellen, Metal sur arbres

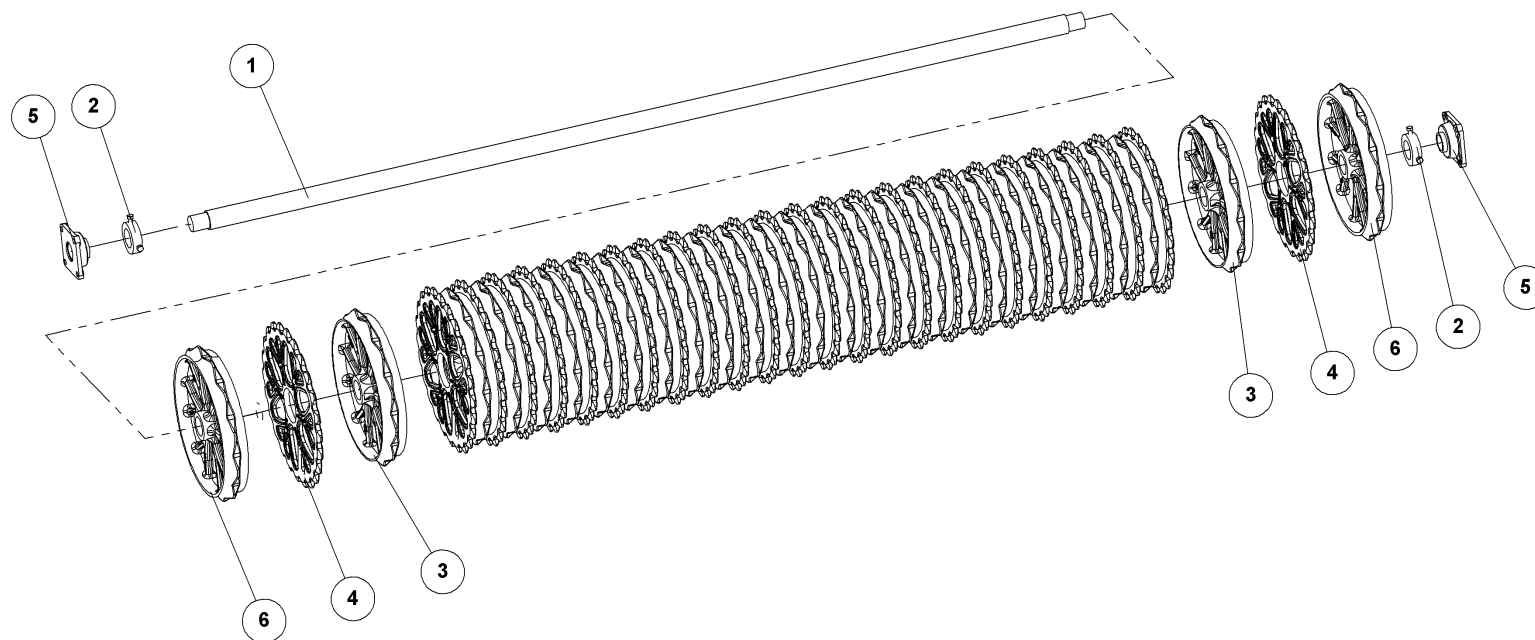

GODS PÅ AKSEL 1030X50 L=2940
CAMBRIDGE SNOWFLAKE

SATZ GIESSGUT FÜR DIE WELLEN
METAL SET FOR AXLE
MÉTAL SUR ARBRES

37221-7



GODS PÅ AKSEL 1030X50 L=2940

CAMBRIDGE SNOWFLAKE

37221-7

SATZ GIESSGUT FÜR DIE WELLEN
METAL SET FOR AXLE
MÉTAL SUR ARBRES

Pos.	Qty.	Part nr.	Benævnelse	Bezeichnung	Description	Designation
1	1	23386	AKSEL Ø60X2940	WELLE	SHAFT	ARBRE
2	2	12334	STOPRING Ø 60 KPL.	ANSCHLAGRING	STOP BUSHING	BAGUE D'ARRÊT
3	25	15184	50 CM GLAT RING - SNOWFLAKE	GLATTER RING	SMOOTH RING	ANNEAU LISSE
4	26	15185	50 CM TAKKET RING - SNOWFLAKE	GEZAHNTER RING - ATG	NOTCHED RING	ANNEAU DENTÉ -
5	2	12457	FLANGELEJE Ø50 SKF FY 50 TR	KOMPLETTES Y-LAGER	COMPLETE Y-BEARING	PALIER-Y COMPLET
6	2	15187	50 CM GLAT ENDERING - SNOWFLAKE	GLATTER RING	SMOOTH RING	ANNEAU LISSE

Midtersektion, middle section, mittlere section, section centrale

					Lejer Bearing Lager Palier	Stopringe Stop bushing Anschlagring Bague d'arrêt	Aksel Shaft Achse Arbre	Komplet gods på aksel Metal set for axle Satz giessgut für Wellen Métal sur arbres				
	Cambridge SNOWFLAKE				Ø50mm	Ø60mm	Ø60mm					
	50 cm		55 cm		50 cm/ 55 cm	50 cm/ 55 cm	50 cm	55 cm	50 cm	55 cm		
Model	15184/ 15187	15185	15784/ 15787	15785	12457	12457	12334					
MINIMAX 950	25/2	26	25/2	26	-/-	2/2	2/2	23386	23386	22934-7	22534-7	

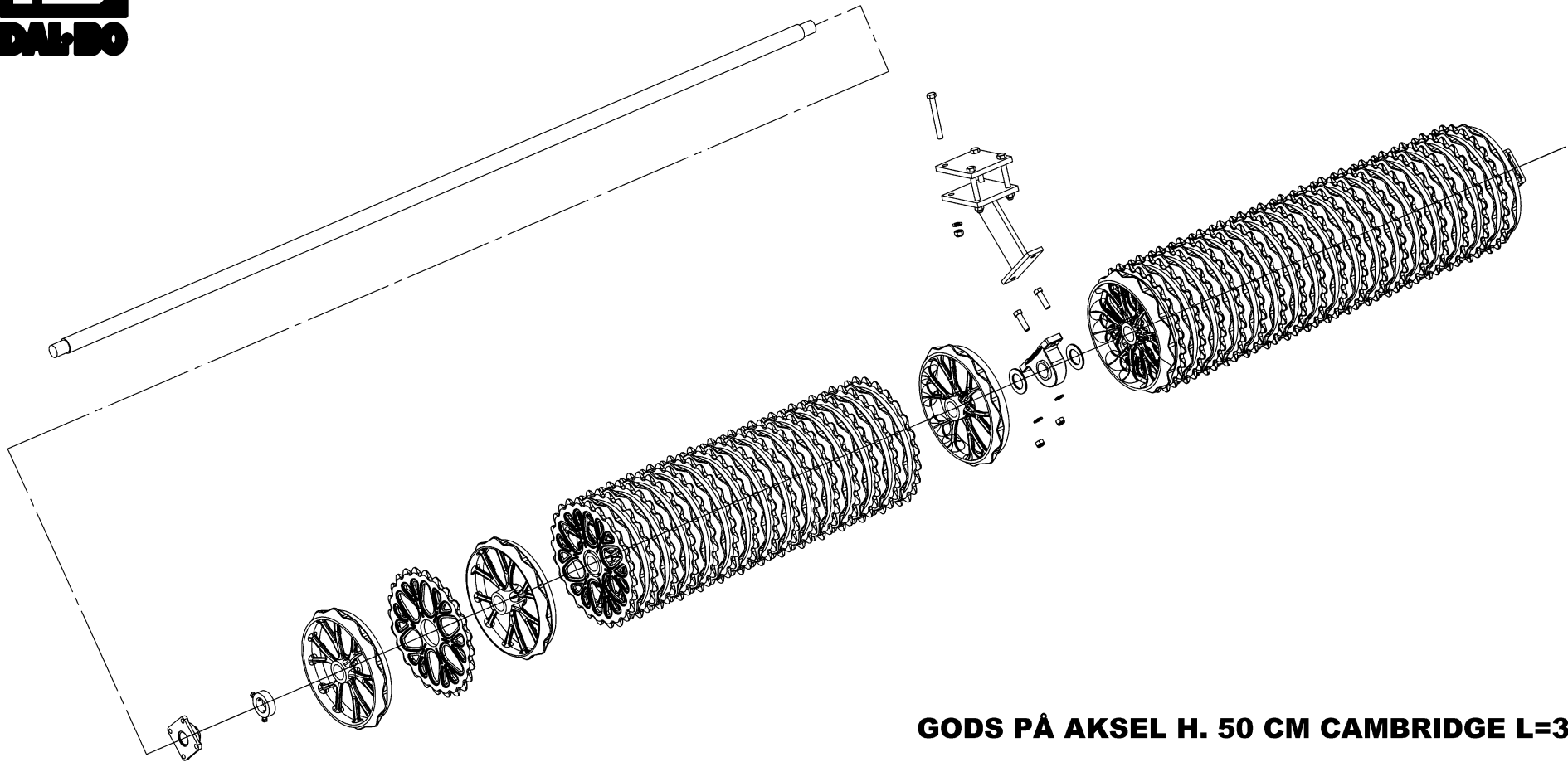

GODS PÅ AKSEL H. 50 CM CAMBRIDGE L=3755
MINIMAX 950 SIDE - SNOWFLAKE





SATZ GIESSGUT FÜR DIE WELLEN
METAL SET FOR AXLE
MÉTAL SUR ARBRES

22938-7

GODS PÅ AKSEL 50 CM CAMBRIDGE L=3755 MINIMAX SIDE – SNOWFLAKE 22938-7

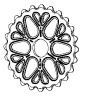
Pos.	Qty.	PART NO.	Part nr.	Benævnelse	Bezeichnung	Description	Designation
1	1	22924	22924	AKSEL Ø60X3750 - MINIMAX 950 SIDE	WELLE	SHAFT	ARBRE
2	1		22928	STØTTE FOR MIDTERLEJE	STÜTZE	SUPPORT	FIXATION
3	1	12459	12459	KOMPLET STÅLEJE Ø60 MM - SKF SYJ6SKF+H2313.	KOMPLETTES STEH LAGER	COMPLETE STEEL BEARING	PALIER COMPLET
4	1	37986-1	37986-1	FLANGEPLADE TIL STØTTELEJE, GALV.	FLANSCHEN	FLANGE	AILE
5	2	92342_20x70	92342	BOLT M20X70 MM 8.8 GALV.	SCHRAUBE	SCREW	BOULON
6	6	Ø21-Ø37-3_90671	90671	SKIVE Ø21-Ø37-3	UNTERLEGSCHIBE	WASHER	RONDELLE DE SERRAGE
7	6	92052_M20	92052	MØTRIK M20, SELVLÅS. GALV. KV. 8.8	MUTTER SELBSTGESICHERT	SELF-LOCKING NUT	ÉCROU DE SÉCURITÉ
8	31	15184	15184	50 CM GLAT RING - SNOW FLAKE	GLATTER RING	SMOOTH RING	ANNEAU LISSE
9	33	15185	15185	50 CM TAKKET RING - SNOWFLAKE	GEZAHNTER RING - ATG	NOTCHED RING	ANNEAU DENTÉ -
10	2	12334	12334	STOPRING Ø 60 KPL.	ANSCHLAGRING	STOP BUSHING	BAGUE D'ARRÊT
11	2	12457	12457	FLANGELEJE Ø50 SKF FY 50 TR	KOMPLETTES Y-LAGER	COMPLETE Y-BEARING	PALIER-Y COMPLET
12	4	92604_20x170	92604	BOLT 20x170 8.8 GALV.	SCHRAUBE	SCREW	BOULON
13	6	Ø62-Ø101-2_90667	90667	SKIVE Ø62-Ø101-2	SCHEIBE	WASHER	RONDELLE
14	2	15189	15189	50 CM GLAT MIDTERLEJERING - SNOWFLAKE	GLATTER RING	SMOOTH RING	ANNEAU LISSE
15	2	15188	15188	50 CM GLAT ENDERING AFDREJET - SNOWFLAKE	GLATTER RING	SMOOTH RING	ANNEAU LISSE

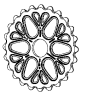
Sidesektion, side section, seiten section, section laterale

							Lejer Bearing Lager Palier		Stopringe Stop bushing Anschlagring Bague d'arrêt		Aksel Shaft Achse Arbre		Komplet gods på aksel Metal set for axle Satz giessgut für Wellen Métal sur arbres	
	Cambridge SNOWFLAKE						Ø50mm		Ø60mm		Ø60mm			
	50 cm			55 cm			50 cm/ 55 cm		50 cm/ 55 cm		50 cm	55 cm	50 cm	55 cm
Model	15184/ 15187	15185	15189	15784/ 15787	15785	15789	12459	12459	12334					
MINIMAX 950	32/2	34	2	32/2	34	2	1/1	2/2	2/2	22924	22924	22934-7	22534-7	

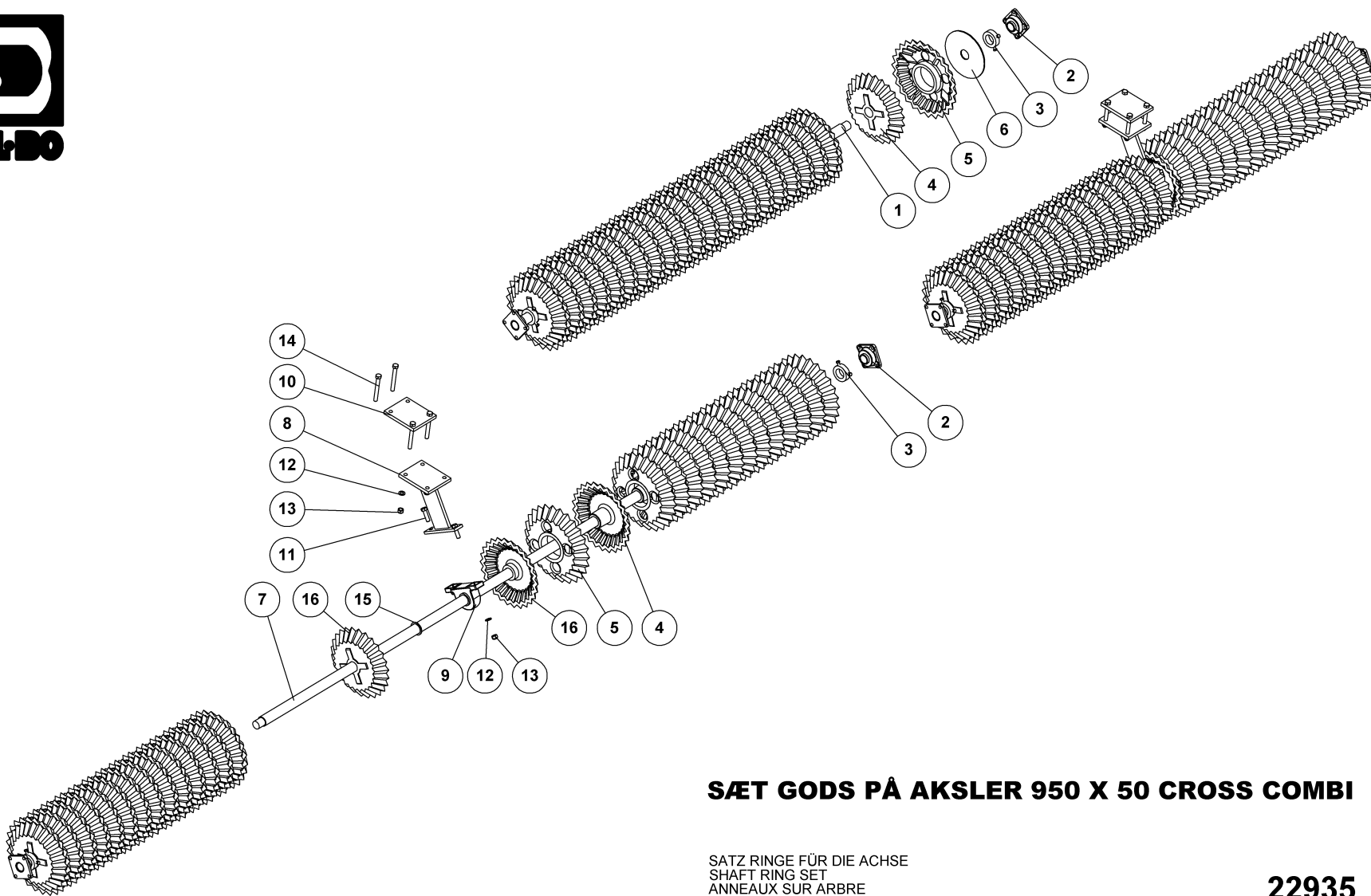

SÆT GODS PÅ AKSLER 950 X 50 CROSS COMBI

SATZ RINGE FÜR DIE ACHSE
SHAFT RING SET
ANNEAUX SUR ARBRE

22935



SÆT GODS PÅ AKSLER 950 X 50 CROSS COMBI

22935

SATZ RINGE FÜR DIE ACHSE
SHAFT RING SET
ANNEAUX SUR ARBRE

Pos.	Qty.	Part nr.	Benævnelse	Bezeichnung	Description	Designation
1	1	23386	AKSEL Ø60X2940	WELLE	SHAFT	ARBRE
2	6	12457	FLANGELEJE Ø50 SKF FY 50 TR	KOMPLETTES Y-LAGER	COMPLETE Y-BEARING	PALIER-Y COMPLET
3	6	12334	STOPRING Ø 60 KPL.	ANSCHLAGRING	STOP BUSHING	BAGUE D'ARRÊT
4	78	18060	CROSS - COMBI Ø450 MM	SATZ RINGE FÜR DIE ACHSE	SHAFT RING SET	ANNEAUX SUR ARBRE
5	78	18061	CROSS - COMBI Ø500 MM	SATZ RINGE FÜR DIE ACHSE	SHAFT RING SET	ANNEAUX SUR ARBRE
6	1	56480	SKIVE TIL CROSSKILL	SCHEIBE DES CROSSKILL	WASHER, CROSSKILL	RONDELLE POUR CROSSKILL
7	2	22924	AKSEL Ø60X3750 - MINIMAX 950 SIDE	WELLE	SHAFT	ARBRE
8	2	22928	STØTTE FOR MIDTERLEJE	STÜTZE	SUPPORT	FIXATION
9	2	12459	KOMPLET STÅLEJE Ø60 MM - SKF SYJ65KF+H2313.	KOMPLETTES STEH LAGER	COMPLETE STEEL BEARING	PALIER COMPLET
10	2	37986	FLANGEPLADE TIL STØTTELEJE	FLANSCHEN	FLANGE	AILE
11	4	92342	BOLT M20X70 MM 8.8 GALV.	SCHRAUBE	SCREW	BOULON
12	12	90671	SKIVE Ø21-Ø37-3	UNTERLEGSCHIEBE	WASHER	RONDELLE DE SERRAGE
13	12	92052	MØTRIK M20, SELVLÅS. GALV. KV. 8.8	MUTTER SELBSTGESICHERT	SELF-LOCKING NUT	ÉCROU DE SÉCURITÉ
14	8	92604	BOLT 20x170 8.8 GALV.	SCHRAUBE	SCREW	BOULON
15	2	93130000590L90L	SKIVNERØR 80X63 ISO2938 ST			
16	4	18059	CROSS - COMBI Ø450 MM - AFDREJET 60 MM	SATZ RINGE FÜR DIE ACHSE	SHAFT RING SET	ANNEAUX SUR ARBRE

Gods på aksel Cross Combi 55, Metal on shaft , Giessgut auf Wellen, Metal sur arbres

22936

Pos.	Qty.	Part nr.	Benævnelse	Bezeichnung	Description	Designation
4	78	18160	CROSS – COMBI Ø500 MM	CROSS-COMBI RING	CROSS-COMBI RING	ANNEAU CROSS-COMBI
5	78	18161	CROSS – COMBI Ø550 MM	CROSS-COMBI RING	CROSS-COMBI RING	ANNEAU CROSS-COMBI
16	4	18159	CROSS – COMBI Ø500 MM – AFDREJET	CROSS-COMBI RING	CROSS-COMBI RING	ANNEAU CROSS-COMBI

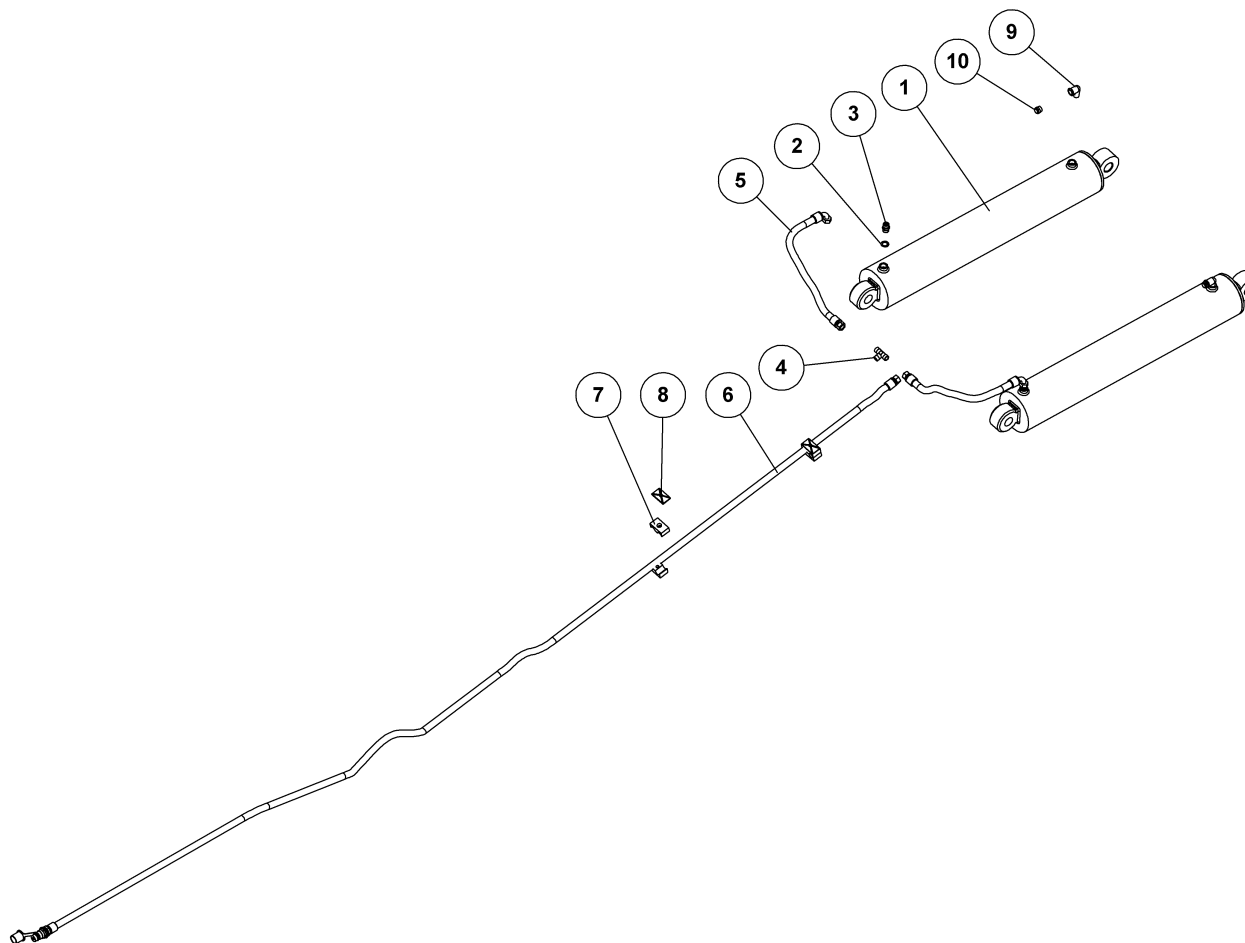

**HYDRAULIK VIPPECYLINDER
MINIMAX 950**

HYDRAULIK HAUPTTRAHMEN
HYDRAULIC MAIN FRAME
CHASSIS HYDRAULIQUE

22496



HYDRAULIK VIPPECYLINDER

MINIMAX 950

22496

HYDRAULIK HAUPTTRAHMEN
HYDRAULIC MAIN FRAME
CHASSIS HYDRAULIQUE

Pos.	Qty.	Part nr.	Benævnelse	Bezeichnung	Description	Designation
1	2	91828	CYLINDER 120X60X700	ZYLINDER	CYLINDER	VERRIN
2	2	91028	3/8" BONDED SEALS PAKRING	BONDED SEALS PAKRING	BONDED SEAL WASHER	JOINT BONDED SEALS
3	2	91003	BRYSTNIPPEL M18 x 3/8" RG GALV.	VERSCHRAUBUNG	HEXAGON NIPPLE CONNECTOR	RACCORD DE JONCTIONS MÂLES
4	1	91006	T-STYKKE M18X1.5 P-TV 12L	T-STÜCK	T-PIECE	T-PIÈCE
5	2	22588	SLANGE M18 L + M18 V L=420 MM	SCHLAUCH	HOSE	TUYAU
6	1	22589	SLANGE HAN + M18 L L=5200 MM	SCHLAUCH	HOSE	TUYAU
7	4	91305	PLASTKLAMME 18 MM DB	PLASTIK KLAMMER	PLASTIC HOSE CLAMP	CROCHET EN PLASTIQUE
8	2	91308	DÆKPLADE T/SLANGEHOLDER	DECKPLATTE FÜR DEN SCHLAUCHHALTER	COVER FOR HOSE CLAMP	DESSUS POUR SUPPORT-TUYAU
9	2	91023	VINKEL 3/8 HAN + 3/8 HUN VANDRØR	WINKELBEFESTIGUNG	CONNECTOR	JOINT D'ANGLE
10	2	91088	UDLUFTNINGSPROP 3/8" RG	LÜFTUNGSSTÖPSEL	AIR RELIEF PLUG	BOUCHON DE VENTILATION

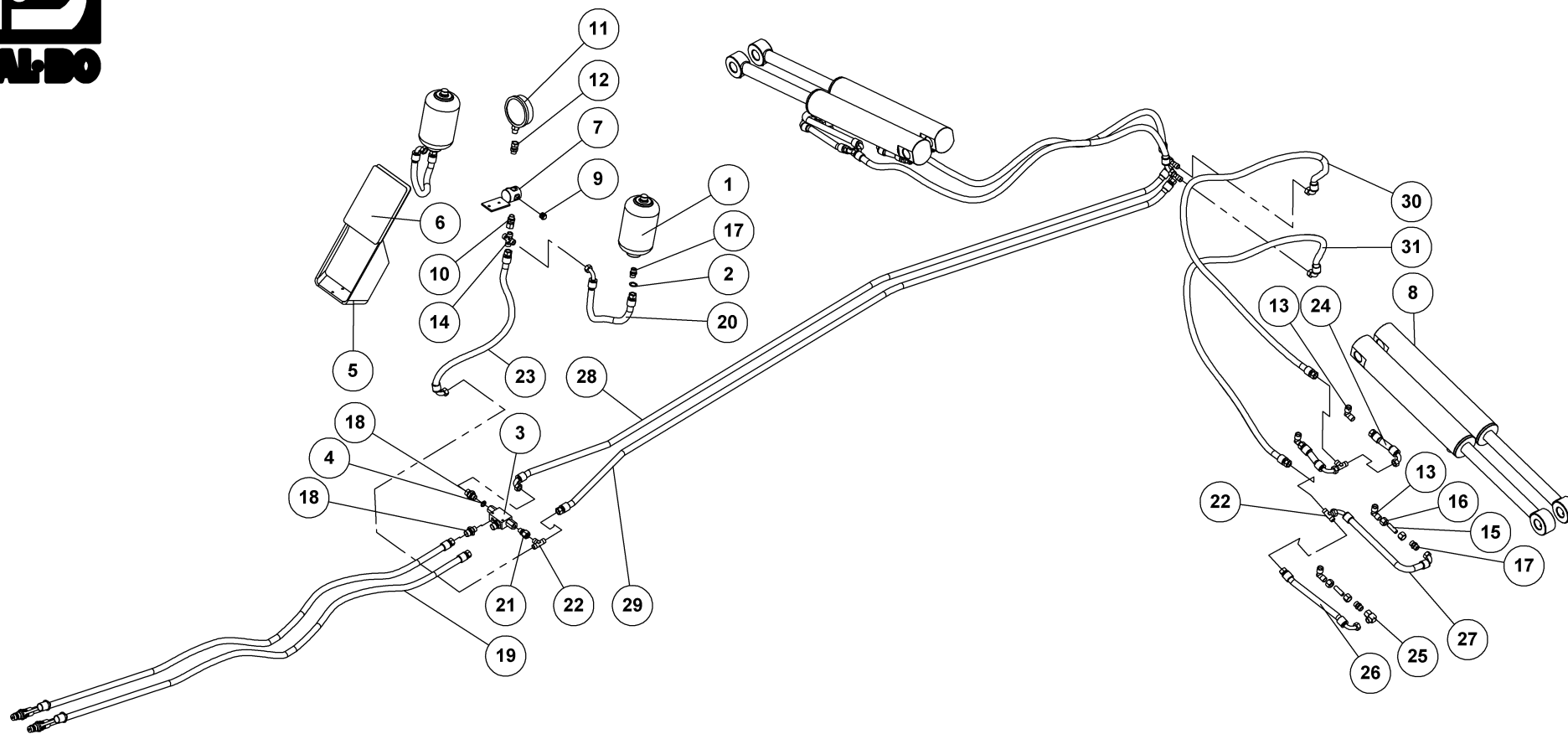

HYDRAULIK SÆT - UDKLAP AF SIDER MINIMAX 950

HYDRAULIK AUS/ZUSAMMENKLAPPEN
HYDRAULIC FOLDING
HYDRAULIQUE DE REPLIAGE

22499



HYDRAULIK SÆT - UDKLAP AF SIDER MINIMAX 950

22499

HYDRAULIK AUS/ZUSAMMENKLAPPEN
HYDRAULIC FOLDING
HYDRAULIQUE DE REPLIAGE

Pos.	Qty.	Part nr.	Benævnelse	Bezeichnung	Description	Designation
1	2	91258	AKKUMULATOR 1 L H1000R - 25 BAR	AKKUMULATOR	ACCUMULATOR	ACCUMULATEUR
2	2	91026	M18 BONDED SEALS PAKRING	M18 BONDED SEALS PAKRING	BONDED SEAL WASHED	JOINT BONDED SEALS
3	1	27396	PILOTSTYRET KONTRAVENTIL 1/4" - ENKELT	PILOTGESTEUERTES SPERRVENTIL EINFACH	PILOT-OPERATED CHECK VALVE, SINGLE	CLAPET DE BLOCAGE PILOTE SIMPLE
4	1	91027	1/4" BONDED SEALS PAKRING	BONDED SEALS PAKRING	BONDED SEAL WASHER	JOINT BONDED SEALS
5	1	37690	SKILT TIL MAXIROLL VED MANOMETER	SCHILD	PLATE	PLAQUE
6	1	91057	FLYDESTILLING	TRANSFER	TRANSFER	TRANSFERT
7	1	37366	ACCUMULATOR HOLDER	ACCUMULATOR HALTERUNG	HOLDER FOR ACCUMULATOR	GARNITURE DE FIXATION
8	4	91805	CYLINDER 80/40X350	ZYLINDER	CYLINDER	CYLINDRE
9	3	91093	SLUTPROP M/PAKNING 3/8"	SCHLUSSSTÖPSEL	END PLUG	BOUCHON DE FERMETURE
10	1	91113	LIGE FORSKR. P-EGES 12 LR-WD-SV	GERADE VERSCHRAUBUNG	STRAIGHT CONNECTION	JOINT DROIT
11	1	91240	MANOMETER 3/8" RG DALBO	MANOMETER	MANOMETER	MANOMÈTRE
12	1	91081	LIGE FORSKR. 3/8"X3/8" MALE/FEMALE	GERADE VERSCHRAUBUNG MÄNNL./WEIBL.	STRAIGHT CONNECTION	JOINT DROIT MÂLE/FEMELLE
13	8	91263	VINKEL P-WEV 12LRK	WINKEL	CONNECTOR	ANGLE
14	1	91007	KRYDS M18 Ø12 GALV. P-KV 12L	KREUZ	CROSS	CROIX
15	4	13315	DRØVLING Ø1,0	DROSSEL	THROTTLE	GRIVE
16	8	91103	OMLØBER M/SKÆRERING M18	VERSCHRAUBUNG	ADAPTOR	RACCORD
17	6	91078	Lige forskrning M18 x M18	GERADE VERSCHRAUBUNG	STRAIGHT CONNECTION	JOINT DROIT
18	3	91073	BRYSTNIPPEL 1/2"RG/M18X1,5 GALV	VERSCHRAUBUNG	HEXAGON NIPPLE CONNECTOR	RACCORD DE JONCTIONS MÂLES
19	2	22573	SLANGE HAN + M18 L L=2700 MM	SCHLAUCH	HOSE	TUYAU
20	2	22574	SLANGE M18 L + M18 V L=350 MM	SCHLAUCH	HOSE	TUYAU
21	1	91114	LIGE FORSKRUNING 1/4"MALE / M18 FEMALE	GERADE VERSCHRAUBUNG	STRAIGHT CONNECTION	JOINT DROIT
22	7	91006	T-STYKKE M18X1,5 P-TV 12L	T-STÜCK	T-PIECE	T-PIÈCE
23	1	22575	SLANGE M18 L + M18 V L=600 MM	SCHLAUCH	HOSE	TUYAU
24	4	22576	SLANGE M18 L + M18 V L=100 MM	SCHLAUCH	HOSE	TUYAU
25	2	91041	STILBAR VINK FORSKR. Ø 12-L-D	WINKELBEFESTIGUNG	CONNECTOR	JOINT D'ANGLE
26	2	22577	SLANGE M18 L + M18 V L=400 MM	SCHLAUCH	HOSE	TUYAU
27	2	22578	SLANGE M18 V + M18 V L=500 MM	SCHLAUCH	HOSE	TUYAU
28	1	22535	SLANGE M18 L + M18 V L=3000 MM	SCHLAUCH	HOSE	TUYAU
29	1	22536	SLANGE M18 L + M18 L L=3000 MM	SCHLAUCH	HOSE	TUYAU
30	2	22537	SLANGE M18 L + M18 V L=1700 MM	SCHLAUCH	HOSE	TUYAU
31	2	22538	SLANGE M18 L + M18 V L=1650 MM	SCHLAUCH	HOSE	TUYAU

Ekstraudstyr, options, Zusatzausrüstung, Accessoires en option
Lys, light set, Beleuchtungsanlage, ensemble de phares

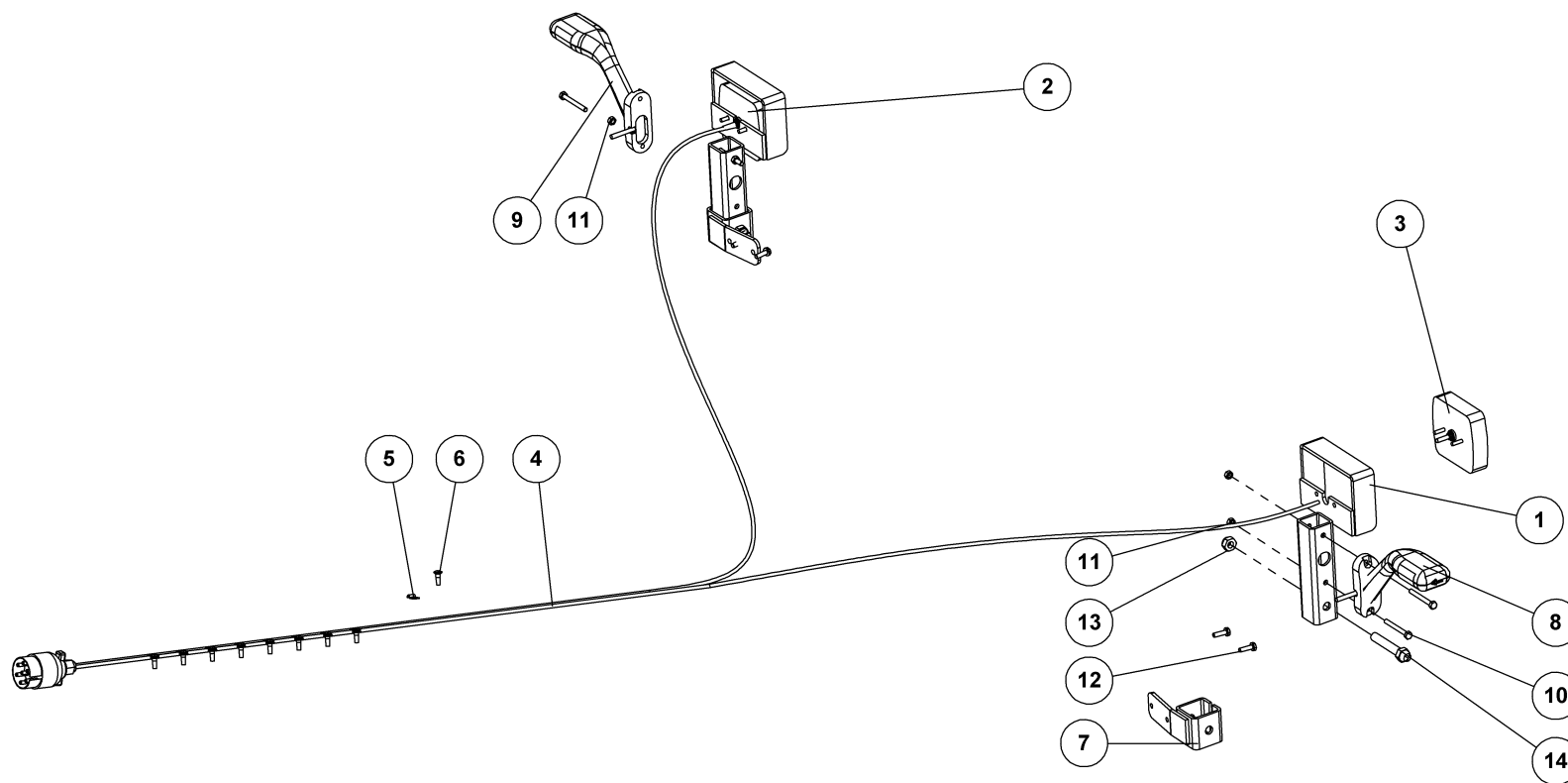

LYGTESÆT - LED

MINIMAX 760/830/930CM

LEUCHTSSATZ
LIGHT SET
ENSEMBLE DE PHARES

23595



LYGTESÆT - LED

LEUCHTSSATZ
LIGHT SET
ENSEMBLE DE PHARES

MINIMAX 760/830/930CM

23595

Pos.	Qty.	Part nr.	Benævnelse	Bezeichnung	Description	Designation
1	2	71454	LYGTESTANDER FÆLLES	LEUCHTSTÄNDER	LIGHT STAND	BÂTON DES LUMIÈRES
2	1	89707	BAGLYGTE LED - HØJRE	RÜCKLICHT - BLINK/STOP/RÜCKLICHT	BACK LIGHTS - TURN/STOP/BACK	PHARE ARRIÈRE -CLIGNO./ARRÊT/PHARE ARRIÈRE
3	1	89706	BAGLYGTE - LED - VENSTRE MED NUMMERPLADELYS	RÜCKLICHT - BLINK/STOP/RÜCKLICHT	BACK LIGHTS - TURN/STOP/BACK	PHARE ARRIÈRE -CLIGNO./ARRÊT/PHARE ARRIÈRE
4	1	89731	KABELSÆT 2x9M - 7-POL STIK - LED	KABELSATZ	CABLE ASSEMBLY	ENSEMBLE DE CÂBLES
5	9	88146	KABELBØJLER 5 mm	KABELHALTER	CABLE BRACKET	COLLIER DE CÂBLE
6	9	92401	GALOPSKRUE PZD. L/H 4.8 x 16	TAPTITE	TAPTITE	TAPTITE
7	2	23362	BEFÆSTIGELSE FOR LYGTESTANDER	BEFESTIGUNG	MOUNTING	FIXATION
8	1	89715	MARKERINGSLYS VENSTRE - LED	LEUCHTE LINKS	MARKING LIGHTS, LEFT	LUMIÈRE DE SIGNALISATION GAUCHE
9	1	89716	MARKERINGSLYS HØJRE - LED	LEUCHTE RECHTS	MARKING LIGHTS, RIGHT	LUMIÈRE DE SIGNALISATION GAUCHE
10	4	92253	BOLT M6X55, U/SKAF T GALV. KV. 8.8	SCHRAUBE	SCREW	BOULON
11	4	92027	MØTRIK M6, GALV. KV. 8.8	MUTTER	NUT	ÉCROU
12	4	92247	BOLT M6X20, FLANGE GALV. KV. 8.8	SCHRAUBE	SCREW	BOULON
13	2	92050	MØTRIK M12, SELVLÅS, GALV. KV. 8.8	MUTTER SELBSTSCHLIESSEND	SELFLOCKING NUT	ÉCROU DE SÉCURITÉ
14	2	92299	BOLT 12x70 8.8 GALV.	SCHRAUBE	SCREW	BOULON

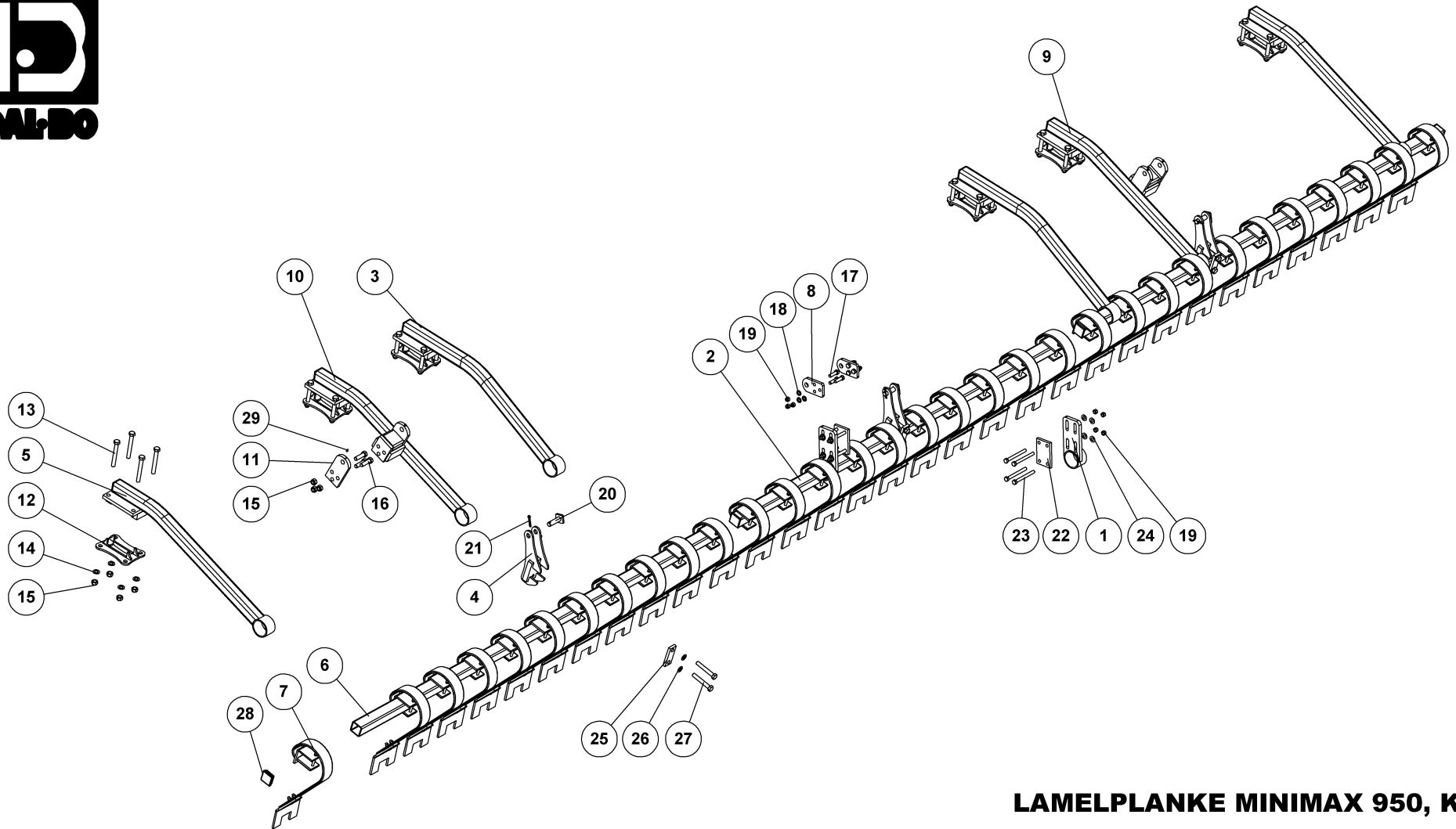

LAMELPLANKE MINIMAX 950, KPL

CRACKERBOARD
CRACKERBOARD
CRACKERBOARD

22920



LAMELPLANKE MINIMAX 950, KPL

22920

CRACKERBOARD
CRACKERBOARD
CRACKERBOARD

Pos.	Qty.	Part nr.	Benævnelse	Bezeichnung	Description	Designation
1	2	22488	BESLAG - OPHÆNG/MONTERING AF	BESCHLAG	MOUNTING PLATE	FIXATION
2	1	93031280090L90L	KIRK-RØR 70X70X5 MM S355			
3	2	22922	ARM T/CRACKERBOARD - KPL.	ARM	ARM	BRAS
4	3	39812	HOLDER. SV	ARM	ARM	BRAS
5	2	38595-4	ARM T/CRACKERBOARD - KPL.	ARM	ARM	BRAS
6	2	93031310090L90L	KIRK-RØR 70X70X5 MM S355			
7	32	91693	LAMELTAND 80MM BRED KPL. M. 200 MM BRED SLIDDEL	CB-ZINKEN	CRACKERBOARD TINE	DENT CB
8	2	22493	PÅ-BOLTNING BESLAG CYLINDER - CB	BESCHLAG	MOUNTING PLATE	FIXATION
9	1	38596-4	ARM VENSTRE T/CRACKERBOARD M. CYL.	ARM	ARM	BRAS
10	1	38597-4	ARM HØJRE T/CRACKERBOARD M. CYL.	ARM	ARM	BRAS
11	2	37907	PLADE TIL CYLINDERFÆSTE - ØVERST	BESCHLAG	MOUNTING PLATE	FIXATION
12	6	23932	SPÆNDPLADE, SV - MINIMAX XL	BESCHLAG	MOUNTING PLATE	FIXATION
13	24	92603	BOLT 20x160 8.8 GALV.	SCHRAUBE	SCREW	BOULON
14	24	90671	SKIVE Ø21-Ø37-3	UNTERLEGSSCHEIBE	WASHER	RONDELLE DE SERRAGE
15	30	92052	MØTRIK M20. SELVLÅS. GALV. KV. 8.8	MUTTER SELBSTGESICHERT	SELF-LOCKING NUT	ÉCROU DE SÉCURITÉ
16	6	92342	BOLT M20X70 MM 8.8 GALV.	SCHRAUBE	SCREW	BOULON
17	6	92314	BOLT 16X55 MM 8.8 GALV.	SCHRAUBE	SCREW	BOULON
18	6	90643	SKIVE Ø17/Ø29X3 MM	SCHEIBE	WASHER	RONDELLE
19	14	92051	MØTRIK M16. SELVLÅS. GALV. KV. 8.8	MUTTER	NUT	ÉCROU
20	3	74312	NAGLE F. Ø25X75(103)	BOLZEN	PIN	AXE
21	3	90677	SPLIT 8X50 MM GALV.	SPLINT	SPLIT PIN	GOUPILLE.
22	2	22489	BESLAG - LAMELPLANKE MIDT	BESCHLAG	MOUNTING PLATE	FIXATION
23	8	92328	BOLT 16x160 8.8 GALV.	SCHRAUBE	SCREW	BOULON
24	8	90663	SKIVE Ø17/Ø35X2 MM	SCHEIBE	WASHER	RONDELLE
25	3	37680	SPÆNDEPLADE Ø21-71-50X15	PLATTE	FASTENING PLATE	PLAQUE
26	6	90644	SPÆND. SKIVE Ø37 X Ø21 X 3	UNTERLEGSSCHEIBE	SEALING WASHER	RONDELLE DE SERRAGE
27	6	92341	BOLT 20x130 8.8 GALV.	SCHRAUBE	SCREW	BOULON
28	6	90766	DUPSKO RHS 70X70 - 2-4	RÖHRENSTÖPSEL	END CAP	BOUCHON DE TUBE
29	4	90721	SMØRENIPPEL LIGE M8x1 MM	SCHMIERNIPPEL	GREASE NIPPLE	GRAISSEUR

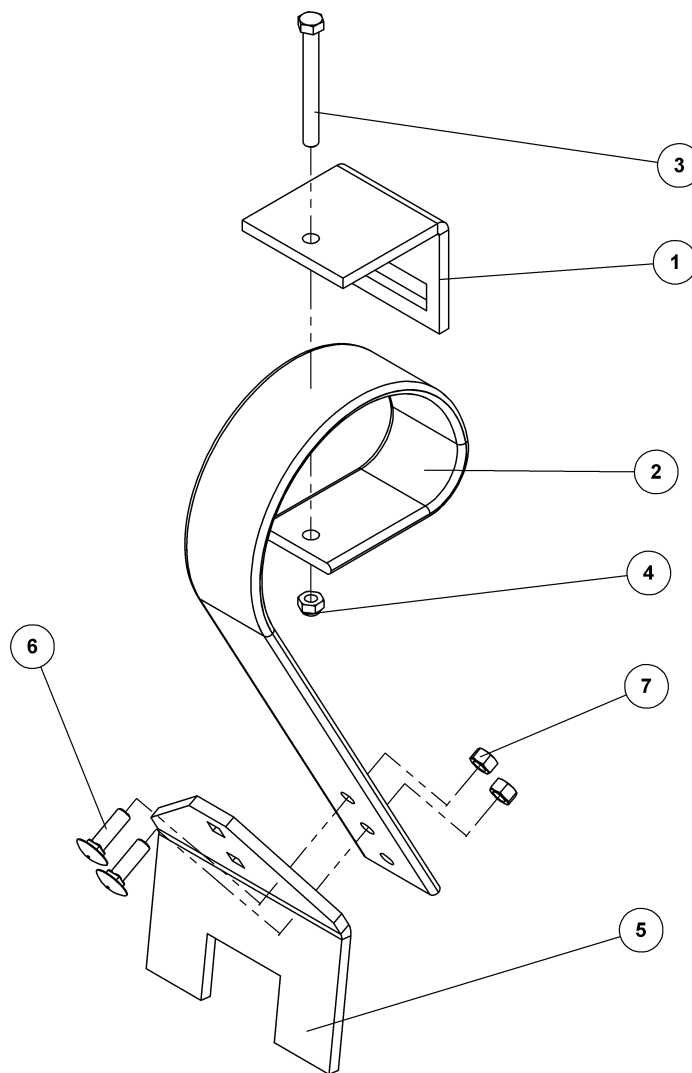

LAMELTAND KPL. M. BRED SLIDDEI

CB-ZINKEN
CRACKERBOARD TINE
DENT CB

91693



LAMELTAND KPL. M. BRED SLIDDEL

91693

CB-ZINKEN
CRACKERBOARD TINE
DENT CB

Pos.	Qty.	Part nr.	Benævnelse	Bezeichnung	Description	Designation
1	1	91721	SPÆNDESTYKKE 10 MM TIL 80 MM TAND	SPANNSTÜCK	PLATE	PIÈCE DE SERRAGE
2	1	91707	LAMELTAND LANG 3 HULS 80MM BRED	CB-ZINKEN	CB - TINE	DENT DE CB
3	1	92303	BOLT 12x110 8.8 GALV	SCHRAUBE	SCREW	BOULON
4	1	92050	MØTRIK M12 SELVLÅS GLV. 8	MUTTER SELBSTSCHLIESSEND	SELFLOCKING NUT	ÉCROU DE SÉCURITÉ
5	1	91735	SLIDDEL BUKKET 200X10	SPITZE GEROGEN	CB POINT	POINT
6	2	92391	BOLT 12X40 GALV (BRÆDDEBOLT)	SCHRAUBE	BOARD BOLT	BOULON
7	2	92030	MØTRIK M12 GALV kl.8	MUTTER	NUT	ÉCROU

Hydraulik for lamelplanke, Hydraulik crackerboard, Hydraulic crackerboard, Crackerboard hydraulique

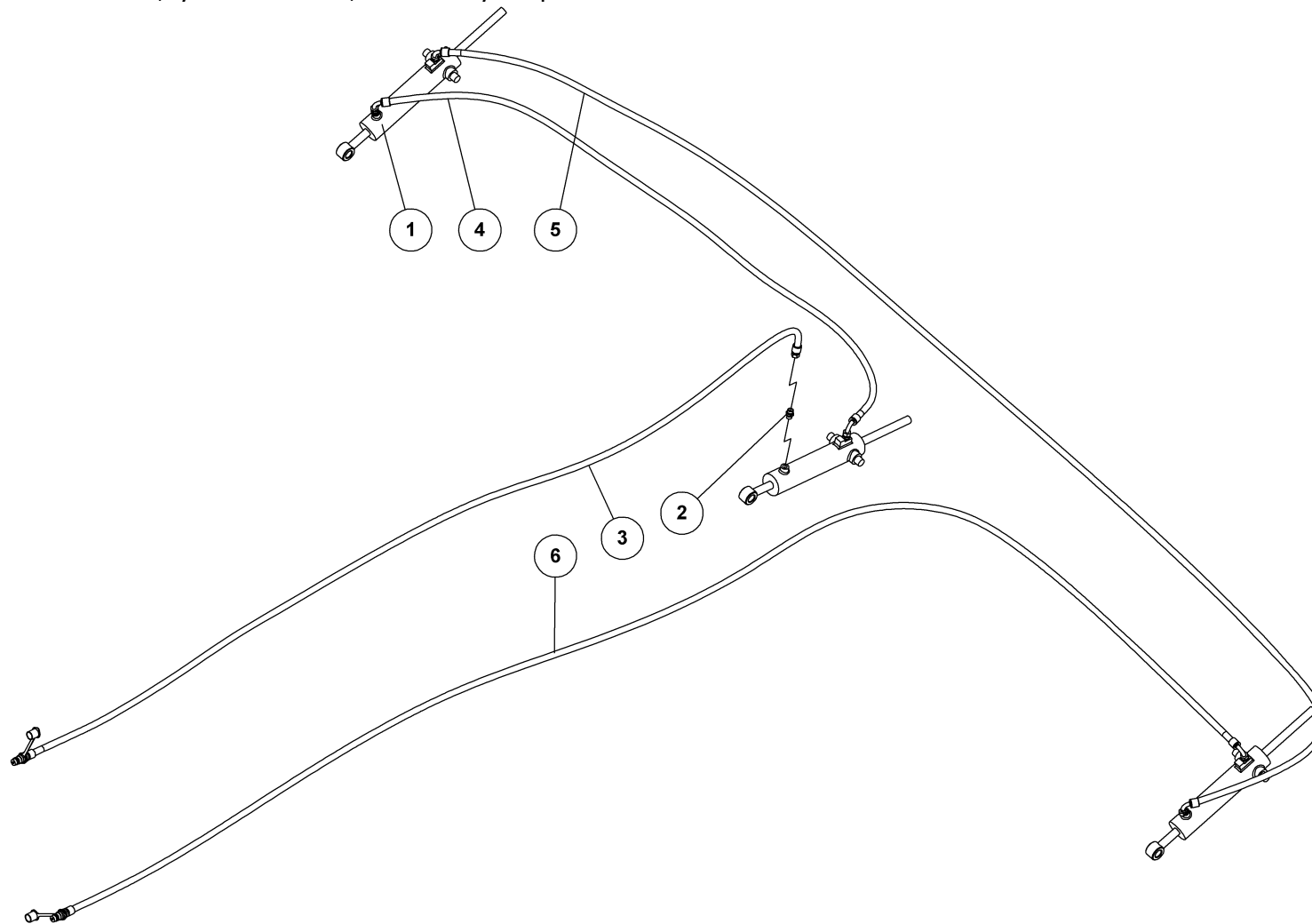

HYDRAULIK SÆT TIL LAMELPLANKE MINIMAX 950

HYDRAULIK CRACKERBOARD
HYDRAULIC CRACKERBOARD
CRACKERBOARD HYDRAULIQUE

22921



HYDRAULIK SÆT TIL LAMELPLANKE MINIMAX 950

22921

HYDRAULIK CRACKERBOARD
HYDRAULIC CRACKERBOARD
CRACKERBOARD HYDRAULIQUE

Pos.	Qty.	Part nr.	Benævnelse	Bezeichnung	Description	Designation
1	3	91792	CYLINDER 25X60X25X205	ZYLINDER	RAN	VERRIN
2	6	91077	LIGE FORSKRUENING M18 x 3/8"	GERADE VERSCHRAUBUNG	STRAIGHT CONNECTION	JOINT DROIT
3	1	22568	SLANGE HAN + M18 V L=5000 MM	SCHLAUCH	HOSE	TUYAU
4	1	22582	SLANGE M18 V + M18 V L=5200 MM	SCHLAUCH	HOSE	TUYAU
5	1	22583	SLANGE M18 V + M18 V L=6500 MM	SCHLAUCH	HOSE	TUYAU
6	1	22584	SLANGE HAN + M18 V L=9700 MM	SCHLAUCH	HOSE	TUYAU

Stenkasse 100 L med beslag, Steinkiste, Stone box, Boite a pierres

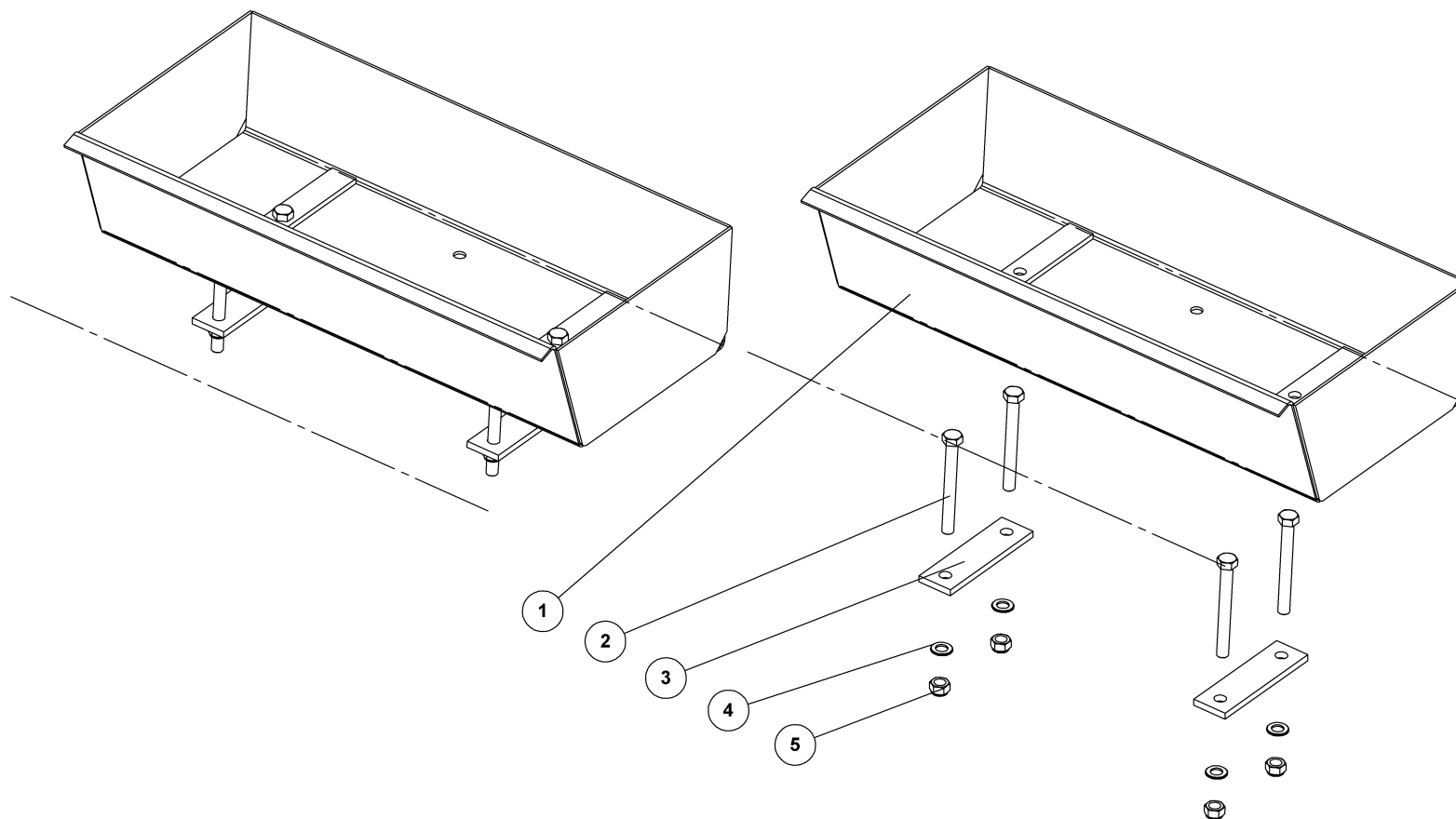

**STENKASSE 2X100L MED BESLAG
MINIMAX**

STEINKISTE
STONE BOX
BOÎTE À PIERRES

23986



STENKASSE 2X100L MED BESLAG MINIMAX

23986

STEINKISTE
STONE BOX
BOÎTE À PIERRES

Pos.	Qty.	Part nr.	Benævnelse	Bezeichnung	Description	Designation
1	2	23960	STENKASSE 100L	STEINKISTE	STONE BOX	BOÎTE À PIERRES
2	8	92339	BOLT 20x180 8.8 GALV.	SCHRAUBE	SCREW	BOULON
3	4	24401	SP/ENDEPLADE Ø21-149-65X12-230	PLATTE	PLATE	PLAQUE
4	8	90644	SP/END. SKIVE Ø37 X Ø21 X 3	UNTERLEGSCHIEBE	SEALING WASHER	RONDELLE DE SERRAGE
5	8	92052	MØTRIK M20, SELVLÅS, GALV. KV. 8.8	MUTTER SELBSTGESICHERT	SELF-LOCKING NUT	ÉCROU DE SÉCURITÉ

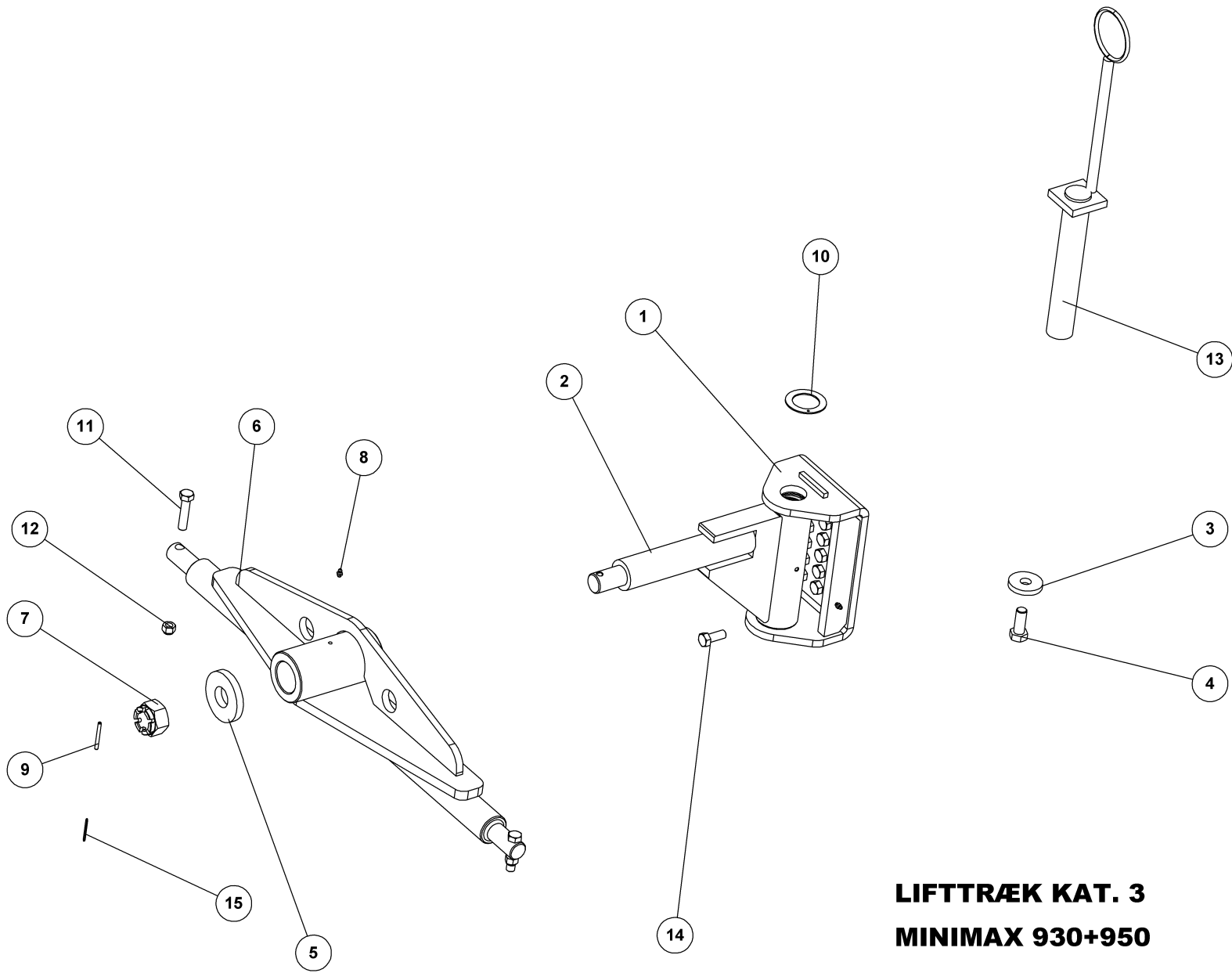

LIFTTRÆK KAT. 3
MINIMAX 930+950

ZUG
DRAWBAR
ATTELAGE

25269



LIFTTRÆK KAT. 3

MINIMAX 930+950

25269

ZUG
DRAWBAR
ATTELAGE

Pos.	Qty.	Part nr.	Benævnelse	Bezeichnung	Description	Designation
1	1	25263	FLANGE TIL TRÆK KPL.	FLANSCHEN	FLANGE	AILE
2	1	74272	TRÆK NAV	ZUG	DRAWBAR HUB	ATTELAGE
3	1	74529	SKIVE Ø21-Ø69-10	UNTERLEGSCHIEBE	WASHER	RONDELLE DE SERRAGE
4	1	92335	BOLT 20x50 8.8 GALV. (SÆTBOLT)	SCHRAUBE	SET SCREW	BOULON
5	1	71380	SKIVE Ø41-Ø100-15	SCHIEBE	WASHER	RONDELLE
6	1	74274	TRÆK KAT. 3 AXR-H	ZUG	DRAWBAR	ATTELAGE
7	1	72384	KRONEMØTRIK M39X3, NV 60 GALV. KV. 8.8	ACHSENMUTTER	SHAFT NUT	ÉCROU D'ARBRE
8	2	90721	SMØRENIPPEL LIGE M8x1 MM	SCHMIERNIPPEL	GREASE NIPPLE	GRAISSEUR
9	1	90688	RØRSTIFT Ø 6x60 MM	ROHRSTIFT	SPLIT PIN	AXE TUBULAIRE
10	2	71251	FORSMURT TRYKSKIVE - Ø78/Ø52/2,6MM	VORGESCHMIERTE DRUCKSCHIEBE	GREASED THRUST WASHER	RONDELLE DE PRESSION LUBRIFIÉE D'USINE
11	2	92319	BOLT 16x70 MM 8.8 GALV.	SCHRAUBE	SCREW	BOULON
12	2	92051	MØTRIK M16, SELVLÅS. GALV. KV. 8.8	MUTTER	NUT	ÉCROU
13	1	74300	NAGLE F Ø50X298(318)M20	BOLZEN	PIN	AXE
14	18	92316	BOLT M16x40 MM 8.8 GALV.	SCHRAUBE	SET SCREW	BOULON
15	1	90689	RØRSTIFT Ø3,5X50	ROHRSTIFT	SPLIT PIN	AXE TUBULAIRE