

DALBO®

ROLLOMAXIMUM



EN
620/750 cm
Serial no.: 00100-XXXX

MADE IN **D**ENMARK

ROLLOMAXIMUM

Types 620/750 cm

Congratulations on the purchase of your new multifunctional agricultural implement. For **safety reasons** and to achieve optimum performance from the product, please read the User Guide **before use**.

©Copyright 2002. All rights reserved, DALBO A/S

Machine specifications:

Type no.: _____ Serial no.: _____
Month of manufacture: _____ Net weight kg: _____

If contacting the manufacturer regarding spare parts or service, please state type and serial number. A spare parts list is included at the back of this manual.

EU DECLARATION OF CONFORMITY

DALBO A/S
DK-7183 Randbøl

declares herewith that the above machine is manufactured in accordance with the provisions of directive 2006/42 EC, which replaced directive 98/37/EC and change directives 91/368/EEC, 93/44/EEC and 93/68/EEC on harmonisation of member state legislation concerning health and safety requirements related to the construction and manufacture of machines.



This machine corresponds to the safety requirements in the European Safety Guidelines.

DALBO A/S

Date: _____

Alessio Riulini, CEO

Table of Contents

SAFETY.....	5
<i>General</i>	6
<i>Hydraulics</i>	7
<i>Assembly</i>	7
<i>Maintenance and repair</i>	7
<i>Road transport</i>	8
<i>Correct use</i>	8
<i>Technical data</i>	8
HOW TO USE THIS MANUAL	8
<i>Delivery</i>	9
LIMITATIONS TO USE	9
DESCRIPTION OF THE MACHINE.....	10
<i>Construction</i>	10
CONNECTING AND DISCONNECTING	11
<i>Connecting</i>	11
<i>Hydraulics</i>	11
<i>Disconnection</i>	12
SETTING UP.....	12
<i>Adjusting drawbar height</i>	12
DRIVING AND OPERATION	13
<i>Extending and retracting</i>	13
<i>Extension</i>	13
<i>Retraction</i>	15
<i>Adjustment of hydraulic weight transfer system</i>	17
<i>Excess pressure</i>	17
<i>Insufficient pressure</i>	17
<i>Operating speed</i>	18
<i>Adjusting crackerboard</i>	18
<i>Adjusting harrowing depth</i>	19
.....	19
<i>Adjusting the rear levelling board</i>	20
<i>Adjusting the rear cross-kill board</i>	20
TYRE PRESSURE	21
MAINTENANCE	22
<i>Lubrication</i>	22
<i>Adjustment</i>	24
<i>Wheels</i>	24
<i>Hydraulics</i>	24
REPLACEMENT AND REPAIRS	24
<i>Hydraulics</i>	25
<i>Replacing the extend/retract cylinder for the side sections (red)</i>	25
<i>Replacement of wheel cylinder (yellow)</i>	27
<i>Replacing the harrow hoist cylinder (blue)</i>	27
<i>Replacing the crackerboard cylinder (green)</i>	28
<i>Removal/fitting wheel</i>	30
<i>Replacing rollers</i>	30
HYDRAULIC DIAGRAM.....	31

ROLLOMAXIMUM

GUARANTEE32
SCRAPPING.....33
SPARE PARTS34

Safety



This symbol appears in the instruction manual each time there is a safety warning concerning your safety, the safety of others or the safe operation of the machine. All safety instructions must be observed and made available to all users of the machine.

General

- Ensure you are familiar with all aspects of the machine before use
- There are safety stickers on the machine containing important instructions for the safety of yourself and others, and correct use of the machine.
- Do not carry passengers during operation or transport.
- Ensure there are no personnel within the machine's extension radius before operating the implement. Only operate machine from inside the tractor.
- When the implement is retracted, check that the side sections are locked. Check all control levers are secured against accidental operation.
- Before leaving the tractor or making adjustments, performing maintenance or repairs on the implement, extend fully and lower it to the ground, or maintain it in the transport position. Apply tractor handbrake, switch engine off and remove ignition key to secure the machine against accidental operation.
- Never leave driver's seat while the machine is moving.
- Always adjust speed to conditions.
- Do not use machine unless all safety devices are in place. Defective safety devices must be replaced immediately.

Hydraulics

- Fold out machine and set down on an underlay for any repair work on the hydraulic system. Relieve hydraulic pressure, switch engine off and remove ignition key.
- Clean hydraulic connections thoroughly before reconnecting. When connecting hydraulic hoses to tractor hydraulics, ensure they are not under pressure.
- It can be difficult to completely depressurise hydraulic systems with pilot-controlled non-return valves. Hold a cloth around the fittings/part to be removed to catch any oil.
- Bleed the hydraulic system thoroughly after any repairs.
- Check hydraulic hoses regularly for defects such as cracks, splits, crimps, wear or breaks. Defective hoses must be replaced immediately.
- Avoid spilling oil on the ground. If oil is spilt, collect and deliver to a disposal point.
- Clean hands thoroughly after contact with oil and grease. Change oil-stained clothing immediately. Hydraulic oil can be harmful to the skin.
- Hydraulic oil released under high pressure can penetrate the skin and cause severe injury. In the event of injury, seek medical help immediately.

Assembly

- Danger of crushing! Ensure no personnel are between implement and tractor, or between the parts to be connected.

Maintenance and repair

- Ensure machine is adequately supported or fully extended for all repair and maintenance work. Ensure tractor and machine are properly braked, engine stopped and ignition key removed.
- Tighten all screw connections after a few hours use. Check all screw connections regularly and tighten as required. Check all split pins and bolts to avoid mechanical failure.
- Dispose of oil, grease and filters in accordance with local environmental protection rules.

Road transport

- All statutorily required safety and warning features must be fitted and tested before transporting the machine on public roads. The driver is responsible for correct lighting and warning signs in accordance with traffic regulations.
- Check with local traffic authorities whether transport on public roads is allowed given the machine's dimensions.
- When transporting, ensure permitted total weight for tractor is not exceeded and that loading on tractor front axle is not less than 20% of tractor net weight. If this is the case, use weights on tractor front.

Correct use

- Correct use of the machine includes observing the manufacturer's operating, maintenance and repair instructions, and ensuring that original spare parts are always used.
- The implement may only be used, maintained or repaired by persons who are familiar with it and who are aware of the risks that may be involved.
- The manufacturer cannot be held liable for injury or damage arising from modifications made to the machine performed without its prior agreement. Neither can the manufacturer be held liable for injury or damage arising from incorrect use. Such liability rests solely with the user.
- Do not add extra weight to the implement.

Technical data

ROLLOMAXIMUM

Width (cm)	620	750
HP (recommended)	Min. 175	Min. 225
Weight in kg (cross-kil):	6.150	6.910
Transport width	3.00 m	3,00 m
Sections back (pcs.)	4	4
Axes front (pcs.)	2	2
Wheels	520/50-17	520/50-17
Brakes	No	No
Light	Yes	Yes

How to use this manual

The sequence of topics in this manual may at first glance not always appear to be logical. Please refer to the table of contents for page numbers for individual items.

The manual is divided into main sections:

- Safety
- Description of the machine, including settings
- Starting routine and running
- Maintenance
- Repairs

The following symbols represent:



Points which are important to functionality and service life.



Points relevant to safety.

Delivery

ROLLOMAXIMUM is delivered complete on a trailer or separated into sections.

If the sections are to be hoisted, attach straps to the respective sections so that they are balanced.

Limitations to use

The following describes what the machine can and cannot be used for:

- The machine may only be used for levelling, compacting and harrowing cultivated land. Fields on which the machine is used must be well tilled, i.e. without major unevenness or potholes.
- The machine can only be used when drawn by a tractor, attached to the tractor drawbar.
- Max. speed when in use is 10 km/h. Speed must always be adapted to suit the terrain.
- When turning at headlands raise machine off the ground, preventing effects of unnecessary wear and tear, especially on machines fitted with Crosskill rings ahead of the harrow.

Any other use of the machine which does not meet the above conditions will be considered as unauthorised use, and will invalidate the guarantee.

Description of the machine

Construction

The ROLLOMAXIMUM is a robust, multifunctional agricultural implement with the following features:

- The machine consists of 5 different working implements. At the front there is a parallel-mounted hydraulically adjustable crackerboard, followed by a 053/048 cm cross-kill roller. This in turn is followed by a harrow with four rows of hydraulically adjustable tines. The maximum harrow depth is adjusted mechanically by a "hydro-clip" on the hydraulic lift, but the entire harrow section is hydraulically raised off the ground, for example when turning at headlands. The surface is levelled again by a spring-mounted mechanically adjustable levelling board. Finally the ground is compacted with a row of 050/045 cm cross-kill rings.
- The side sections are fitted with a hydraulic weight transfer system, which is designed to transfer some of the weight from the machine centre section to the side wings, in order to ensure uniform tilling of the ground across the full width of the machine.

- For optimum protection of the machine's core components, all assemblies are mounted on spring mechanisms.
- ROLLOMAXIMUM is designed to receive the following optional extras:
- The machine can be optionally fitted with track looseners for tractor rear wheel widths of up to 4.5 metres. In addition, the cross-kill rings can be replaced with a Ø50 cm front roller cage and a Ø45 cm back roller cage.



Connecting and disconnecting

Connecting

ROLLOMAXIMUM may only be coupled to the lower linkage on the tractor.

Loosen the pin (B) and move up the support leg (C) and fix it with the pin (B) again.

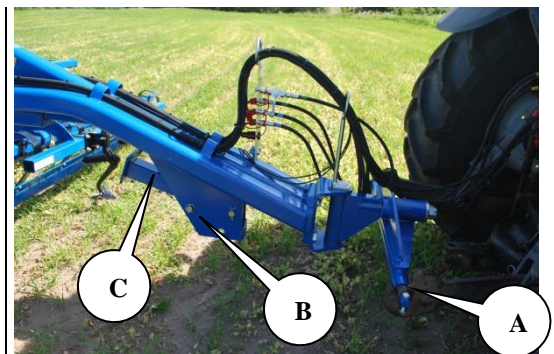

- Lower linkage pin must be secured with a split pin or similar.
- Note that hydraulic hoses and the support leg are mounted so that they are not damaged by the tractor's lift arms and tyres when the tractor / machine train is turned.



Hydraulics

ROLLOMAXIMUM 620 requires the standard four double-acting and single-acting hydraulic couplings, whereby the assignment and colour-coding are as described in the table on the next page.

Hose markings

No. in valve block	Cylinder name	Colour	Outlet	Function
-	Retract/weight equalisation	Red	Double-acting	Retracts/extends side sections and distributes weight from mid-section to side sections, when the machine is in the working position. Connected with manometer and requires float position when working in the field.
-	Crackerboard front	Green	Double-acting	Adjusts the working intensity at the front crackerboard.
-	Transport wheel	Yellow	Double-acting	Adjusts the position of the transport wheels.
-	Harrow section	Blue	Double-acting	Adjusts the working depth of the harrow section.

- Check hydraulic hoses for crimping before coupling.



Disconnection

ROLLOMAXIMUM should be folded up (into the transport position) or folded out into the working position with the transport wheels lifted off the ground before disconnection.

The support leg is adjusted so that the drawbar is free in the lower linkage above and below. Remove then lower linkage arms and hydraulic pipes.



Remember to depressurise hoses before disconnecting them. When the machine is disconnected in transport position, the machine should remain stationary on the transport wheels and on the hydraulic support leg. Do not use the centre cross-kill a e as a support.



ROLLOMAXIMUM may only be disconnected on a level surface.

Setting up

ROLLOMAXIMUM is supplied with factory settings, but fine adjustment will always be required before use. Numerous adjustment options make the machine more flexible and optimise its use.

To ensure that the ground is uniformly worked, the drawbar must be correctly aligned to the tractor used.

Adjusting drawbar height

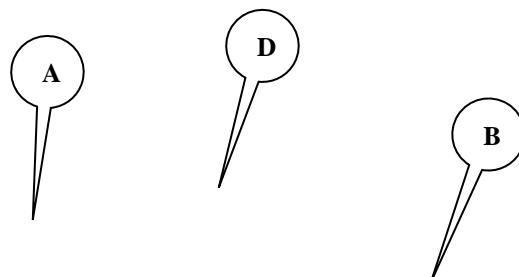

Supported on a level concrete floor or similar, the machine is folded out to working position and the transport wheels (A) raised free. The crackerboard (B) and harrow section (C) are also raised, so that the machine is now only supported by the two compaction sections. In this position, the entire drawbar shaft (D) should be level. If it is not so, the assembly should be adjusted by the lower linkage (E) on the tractor.

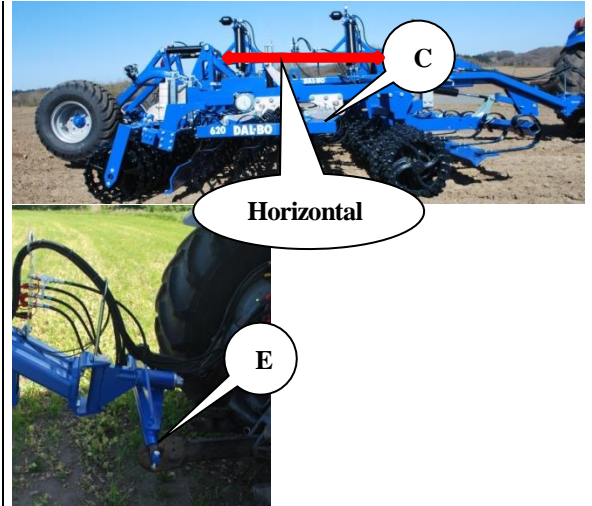

Driving and operation

Correct operation is vital to get the most out of the ROLLOMAXIMUM. This applies to working in the field and to safety. Always ensure you are fully familiar with all safety features of the machine.

Extending and retracting



Extending and retracting the machine must always be performed with the tractor parked, and on a level surface.



Ensure there are no personnel within the machine's working radius when extending or retracting.

Extension

Lift up the machine as high as possible with the wheel frame (A) [marked: Yellow].

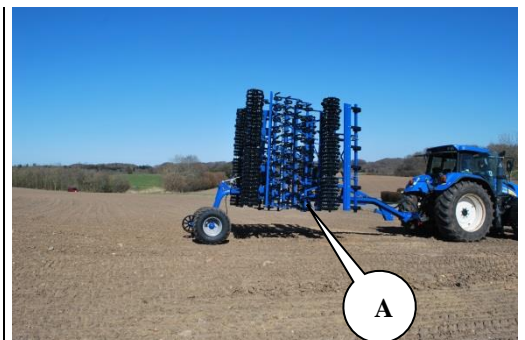

ROLLOMAXIMUM

Extend/retract cylinder (marked: Red) is activated and the side sections are completely folded out.



The wheel frame (marked: yellow) is activated and the wheels are lifted off the ground. Extend/retract cylinder (marked: red) is actuated until the desired operating pressure is indicated on the manometer and is set to the float position.



Retraction

The wheel frame (marked: yellow) is activated and the machine is lifted off the ground.



The extend/retract cylinder (marked: red) is activated again and the side sections are retracted into vertical position (A).

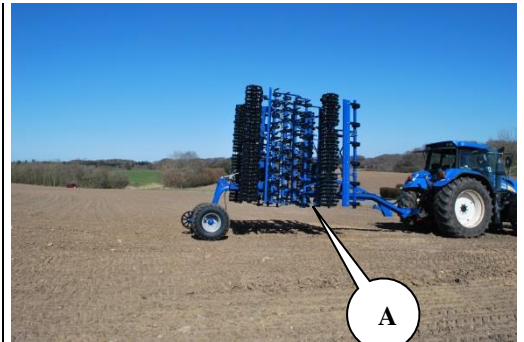

To reduce the height of the machine's centre of gravity and make a safe transport, the machine can be lowered via the wheel frame (A) (marked: yellow) and the lower linkage on the tractor (C). The machine is lowered until there is approx. 20 cm of clearance under the lowest part of the frame (B).

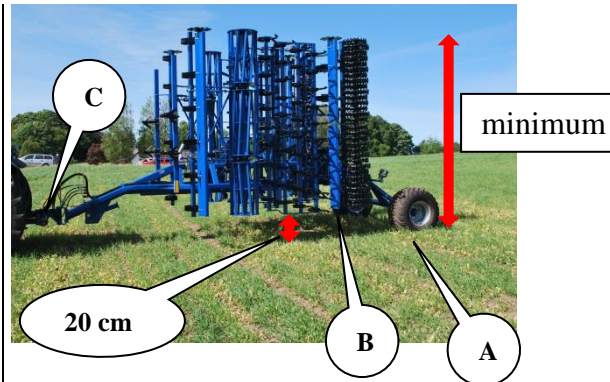

ROLLOMAXIMUM

To reduce the machine's transport width to a maximum of 3 metres, the harrow section is activated (A) [marked: blue], so that they are pulled as far in to the machine's centre as possible. The same is done with the machine's cracker-board (B) [marked: green]

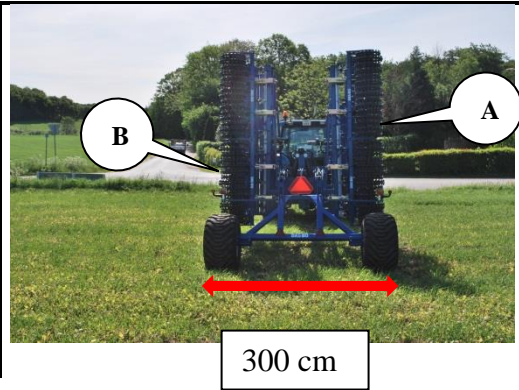

Always **observe the correct sequence** when retracting. i.e., the wheel frame [marked: yellow] is first activated and the machine is lifted off the ground. The side frames can then be retracted via the extend/retract cylinders [marked: red].



This is very important for the machine's durability and safety that the side frames remain in the transport secures (A below), when the machine is transport in the retracted state.

The secures (A) must be in fixation with the sideframes, when the machine is transport in the retracted state.



Adjustment of hydraulic weight transfer system

The hydraulic weight transfer system distributes the weight evenly between all the machine's sections.

Once the roller is fully extended and the transport wheels are off the ground, the extend/retract cylinders are depressurised (marked: red), the cylinder control lever is then moved in the opposite direction.

This is indicated after a short delay by a deflection of the manometer. The pressure is increased to approx. 50 bar (B). Some of the weight from the machine's centre is thus transferred to the side sections.

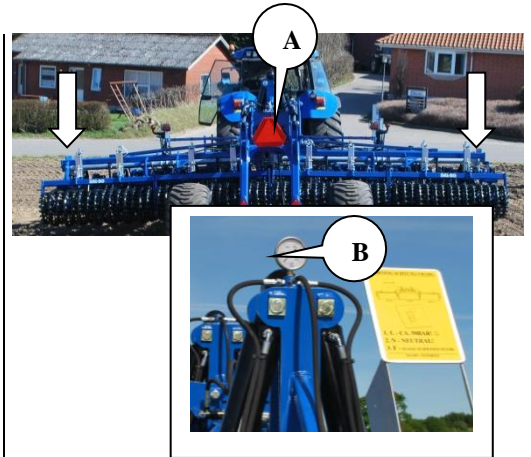

The control lever connected to the outlet (marked: red) is then set to the float position. The floating setting is required to achieve hydraulic weight transfer, allowing the sections to move independently and protecting the machine's key components. The pressure will remain indicated on the manometer after float position has been adopted.

The pressure for hydraulic weight transfer may need adjustment. It may also be necessary to adjust pressure according to soil conditions.

Excess pressure

- 1 Pressure on the side sections will be too great, leaving clear tracks in the soil after the side sections have passed.
- 2 The centre section will not compact the soil enough, as the soil after the centre section has passed is higher and not as compacted as that worked by the side sections.

Insufficient pressure

- 1 The pressure on the extremities of the side sections will be insufficient to give uniform compaction.
- 2 The mid-sections will compact the soil too much, leaving the soil after the mid-section has passed more compacted than that worked by the side sections.



To prolong the ROLLOMAXIMUM's service life and to optimise the tilled field finish, it is very important that the extend/retract outlet (marked: Red) is set to the float position for field work.



If the outlet (marked: red) is not set to float position, this constitutes incorrect use and in the worst case may cause the frame to break.

Operating speed

An operating speed of 6-10 km/h is recommended, but always operate according to conditions.

Power requirement will depend on soil type, terrain and speed. This is a crucial factor as it determines the working depth with crackerboards and the harrow section.

Table 2, **Guide to power requirement in HP**

Working width	620	
Power requirement	Min. 175	

Adjusting crackerboard

Crackerboard depth (A) is hydraulically adjustable.

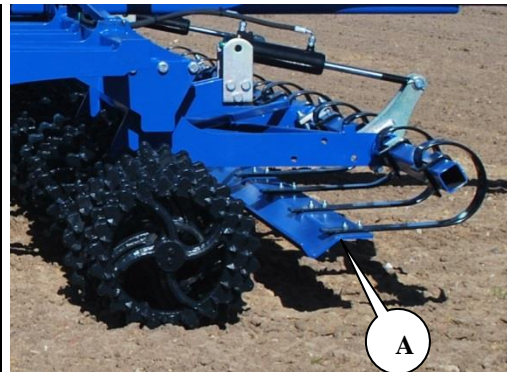

- For an **aggressive tine setting** (vertical) make the spindles shorter.
- For a **passive tine setting** (horizontal) make the spindles longer.

The crackerboard is a flexible unit with a range of applications. When the depth is set to 5 cm, the vibrating effect of the tines will crush clumps.

A deeper setting will increase the levelling effect to that of a levelling board, as a small bank of soil builds up in front of the tines.



It is **not** designed to act as a dozer blade, but to break the soil down. As each tine can move individually and thus yield to localised pressure, the crackerboard is easy to use and requires little adjustment compared to a levelling board.



The crackerboard sections can run at different depths, which means it may be necessary to zero the board by raising it to full height and then proceed to activate the outlet (marked: green). The oil is thereby circulated in the series-connected cylinders and any air in the oil is purged.

Adjusting harrowing depth

The harrow section (A) is parallel mounted and is adjusted vertically up and down by the double-acting coupling (marked: white valve block no. 3).

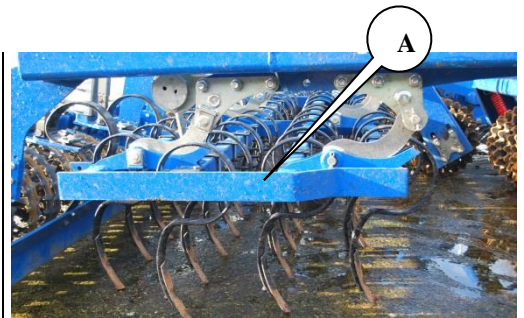

The harrowing depth is adjusted incrementally by the "hydro clip" spacer rings (B), which are mechanically mounted by hand on the harrow section's raise/lower cylinder on each side. In total, there are two cylinders on the machine, and the same and equal number of spacer rings must be fitted to each.

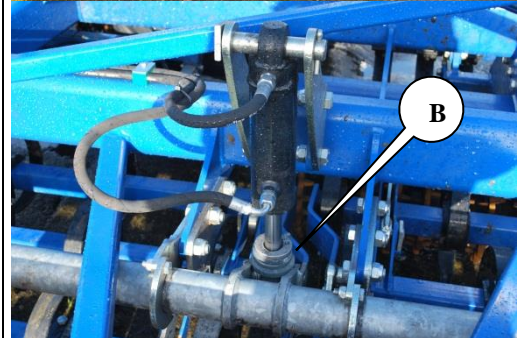

The hydro-clip spacer rings (C) are stowed on the scale (D), when not in use. If no spacer rings are used on the cylinder, the harrow can go to the maximum depth. Two types of hydro-clip are supplied with the machine with a total of 4x 31.8 mm and 6x 21.4 mm rings. As the spacer ring is changed with 10.4 mm on the cylinder rod, the harrowing depth changes by 12.1 mm, i.e. the ratio is 1:1.16.

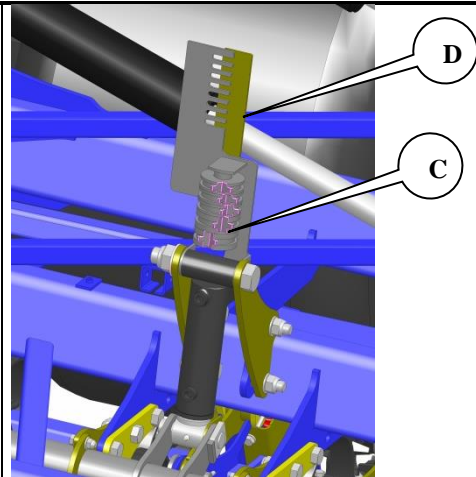

The hydro-clip spacer rings act as bottom stops for the harrow depth. If you wish to make the harrow setting deeper, use more spacer rings and if you want a shallower setting, use fewer. The hydraulic harrow hoist is not designed to be operated without a bottom stop, i.e. with continuous hydraulic depth adjustment, as this will result in an uneven harrowing depth between the sides. The scales (D) are used to indicate that the working depth is the same on both sides.

Adjusting the rear levelling board

The mechanically adjustable rear levelling board is an implement that is exclusively designed to level the surface after the harrow tines to create optimum conditions for the use of the rear cross-kill roller.

The levelling board (A) is spring-mounted and mechanically depth adjustable via spindles (B). There are two spindles per section. All spindles should have a common setting to ensure optimum working across the whole working width.

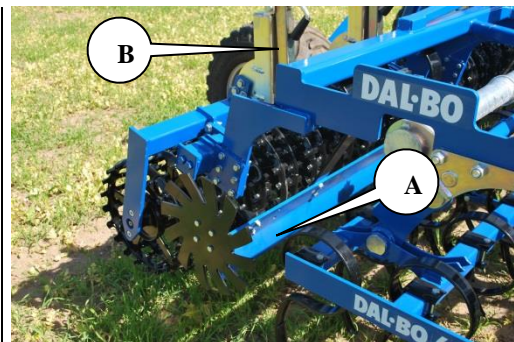

Do not use the rear levelling board as a dozer blade. This will cause unnecessarily loading of the machine and lead to a poor surface finish.

Adjusting the rear cross-kill board

The rear cross-kill roller (A) is adjusted ex works via the row of holes (B) so that the frame (C) is level, when the machine is in the working position on a level surface.

If the underlying soil is very loose, it may be necessary to adjust the compaction mounting via the holes (B) so that the frame (C) is levelled.

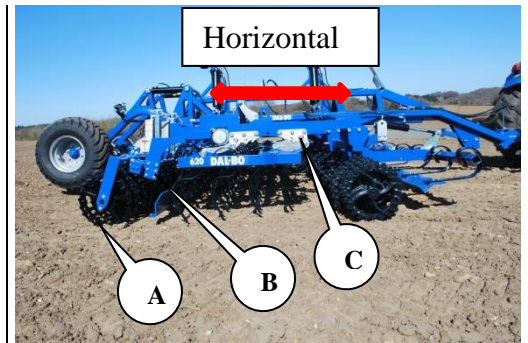

Tyre pressure

In the tables below you can see the load, speed, and tyre pressure relative to each other for the different tyre combinations.

520/50-17 STARCO

Load/Speed/Pressure Schedule

520/50-17 159B TL STARCO SG Flotation (FREE WHEEL)												
	1.0 Bar	1.3 Bar	1.6 Bar	1.9 Bar	2.2 Bar	2.5 Bar	2.8 Bar	3.1 Bar	3.3 Bar	3.5 Bar	3.8 Bar	4.0 Bar
10km/h	2895	3375	3810	4215	4595	4950	5290	5615	5825	6030	6325	6520
15km/h	2570	2995	3380	3735	4070	4385	4685	4975	5160	5340	5605	5775
20km/h	2430	2835	3200	3540	3855	4155	4440	4715	4890	5060	5310	5470
25km/h	2315	2700	3050	3370	3670	3955	4225	4485	4650	4815	5050	5205
30km/h	2175	2535	2860	3165	3450	3720	3975	4220	4375	4530	4755	4900
35km/h	2120	2470	2790	3085	3360	3620	3870	4105	4260	4410	4630	4770
40km/h	2065	2405	2715	3000	3270	3525	3765	3995	4145	4290	4500	4640
45km/h	2005	2335	2635	2915	3175	3420	3655	3880	4025	4165	4370	4505
50km/h	1945	2265	2555	2825	3080	3320	3550	3770	3910	4045	4245	4375

Maintenance

Good maintenance ensures long machine service life and optimum use. Grease nipples are provided where wear is heaviest.



Retighten all screw connections after the first working day. Check all split pins and pins to avoid mechanical failure. Check hydraulic system for leaks.

Lubrication

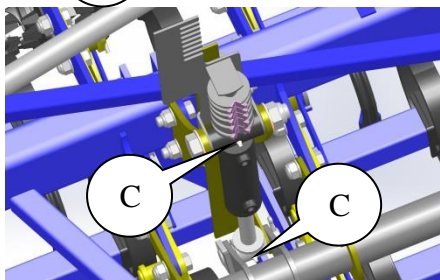
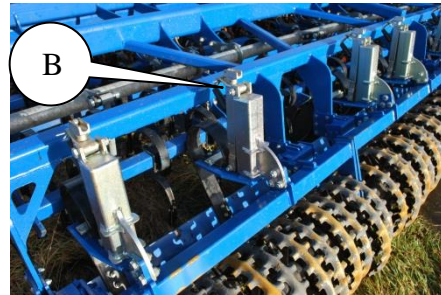
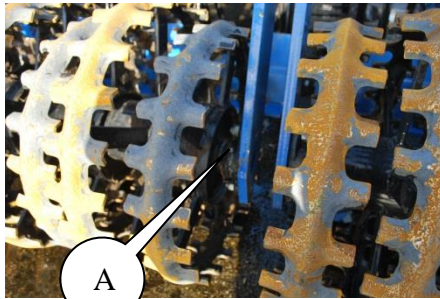

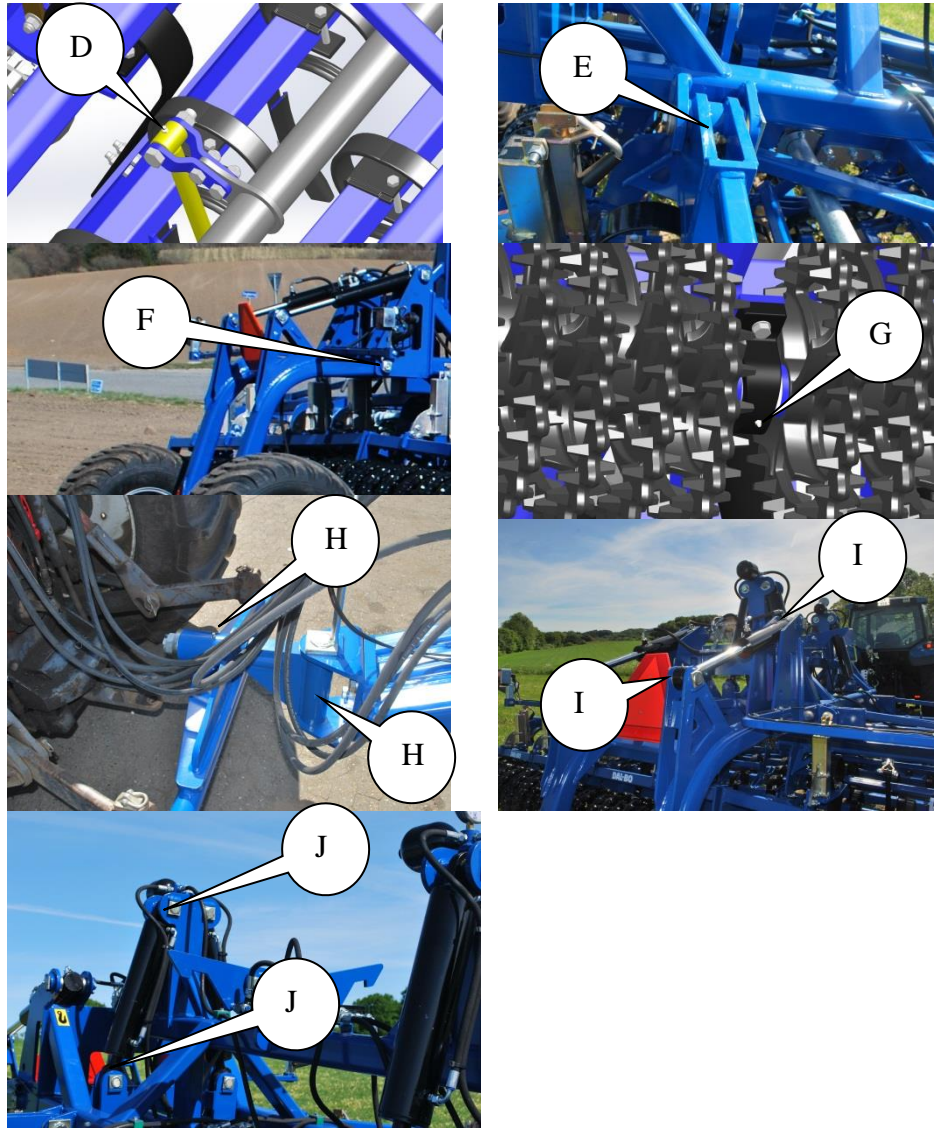

Lubrication points	Number of nipples	Lubrication intervals, hours	Balloon
Flange bearing rear cross-kill roller	8	50	A
Spindles rear levelling board	8	25	B
Cylinders harrow hoist	4	8	C
Parallel-arm harrow hoist	4	8	D
Chassis side frames	4	8	E
Chassis wheel frame	2	8	F
Bearing front cross-kill roller (centre)	4	50	G
Chassis front drawbar	2	8	H
Cylinders wheel frame	4	8	I
Folding cylinder (Red)	8	25	J



Lubricate all lubrication points at least once annually.

Adjustment

Wheels

Lubricate and adjust wheel bearings at least once annually. Check tyre pressures at least once annually (see recommended pressure on tyre).

Adjustment and lubrication of wheel bearings

1. Remove hub caps.
2. Remove split pin.
3. Tighten castle nut 1/6th of a turn until hole aligns with a e. Turn wheel, check for resistance. A little play should be detected in the hub housing when rocking wheel from side to side. If play is excessive, repeat process.
4. Replace split pin
5. Fill hub cap ³/₄ full with grease. Replace.

Hydraulics



Check all hydraulic hoses for wear or cracks. Check all hoses for crimping.



Lubricate exposed rams with oil or pressure-resistant grease to avoid rust forming when storing for long periods. Remember to remove before use.

Replacement and repairs



Safety is vital in the performance of **all** repair work on the machine. Always observe the following points, plus those under Safety First in the instruction manual.



When replacing cylinders, always fill the new cylinder with oil before pressurising system. We recommend fitting the cylinder to the frame first and filling it with oil, before completing attaching at the top.



All maintenance and repair work on the machine may only be performed when it is lowered to the ground or locked in transport position, the tractor is braked, engine stopped and ignition key removed to prevent inadvertent startups.



Particular attention must be paid to safety when repairing the hydraulics. Before commencing work, depressurise the hydraulic system and support the part being worked on.



Always ensure that air is bled out of the hydraulic system after repairs and before use to prevent mechanical breakdowns and personal injuries.

Hydraulics

Replacing the extend/retract cylinder for the side sections (red)

The machine must be fully extended to the working position and resting on the ground for repairs. The transport wheels should then be raised clear of ground.

1. Depressurise the cylinder.
2. Disconnect hoses.
3. Remove split pins and pins. The cylinder is now free.
4. Fit new or repaired cylinder. Check that the pin engages, secure pins with split pins.
5. Connect hoses. Check there is no danger of hoses being ripped or crimped after fitting.





Activate extend cylinder after fitting until cylinder shows movement. Reverse cylinder until it returns to start position. Move cylinder backwards and forwards several times.



If air is not correctly bled off from the cylinder as described above, there is a risk that part of the machine **can suddenly move much quicker than normal, before the tractor driver can prevent it**. This is because air (unlike oil) is compressible. A side section can therefore swing out very quickly if air bleeding is not performed correctly. This represents a major risk of injury to personnel and of damage to the machine.



Ensure no personnel are within the extension radius of the side sections.

Replacing gaskets

REMOVAL:

1. Drain oil from cylinder, use compressed air to move ram backwards and forwards (if required) to force oil out.
2. Extend ram to centre position. Screw upper part (3) 30 mm outwards. If upper part is stuck, heat front of sleeve to approx. 300° C, and allow to cool. When upper part has been unscrewed, extend ram towards upper part. Unscrew and remove upper part, extract ram.
3. Remove lock nut (10).
4. Remove collar shoe (4).
5. Remove upper part from ram (2).
6. Remove gaskets in upper part and collar shoe, (5+6+7+8+9) using an awl or screwdriver if necessary.
7. Clean all parts, check for particles etc. Check for rust around scraper ring (5) on the upper part. If any is detected, remove thoroughly.

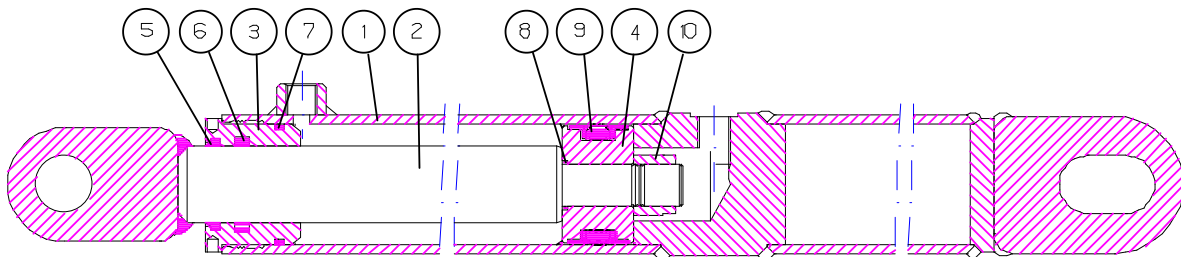

ASSEMBLY:

91800 - 63/40x500long

1. Fit new gaskets in upper part and collar shoe. The scraper ring is mounted using a piece of pipe, passed around outside of lip, (or a special drift). Fit collar (9) onto collar shoe using

- tubular bar or screwdriver.
2. Lubricate thread on upper part and cylinder tube with grease (rust-preventing anti-scratch).
 3. Fit upper part (3) to ram shaft.
 4. Lock collar shoe (4) and lock nut (10) using Loctite.
Ensure that thread is absolutely clean and free of oil or other impurities before applying Loctite.
Do not fill with oil for 12 hours after use of Loctite.
 5. Lubricate collar shoe (9) and cylinder tube end inside using lubricating oil. Push ram into centre position.
 6. Screw on and tighten the upper part (3).

Replacement of wheel cylinder (yellow)

The machine is folded out to the working position, the wheels (B) are lifted off the ground and pressure relieved from the wheel cylinders (A).

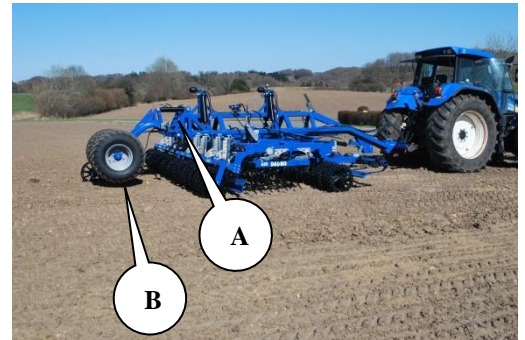

1. Disconnect hoses from cylinder
2. Support cylinder
3. Remove split pins from pins, remove pins
4. Remove cylinder
5. Fit new or repaired cylinder



After the wheel cylinders are fitted, they are actuated until they show a slight travel. Reverse cylinder until it returns to start position. Move cylinder backwards and forwards several times.



If cylinder is not bled correctly as described above, there is a risk that part of the machine **can suddenly move much quicker than normal, and before the tractor driver can prevent it.** This is because air (unlike oil) is compressible. A section can therefore swing out very quickly if air bleeding is not performed correctly. This represents a major risk of injury to personnel and of damage to the machine.



Ensure no personnel are within the extension radius of the side sections.

Replacing gaskets on the wheel cylinder

See the section "Replacing gaskets on tilt cylinder"

Replacing the harrow hoist cylinder (blue).

The machine is extended to the working position, the wheels are raised so that the two cross-kill rollers are resting on the ground. The harrow arms (A) are then lowered so that the harrow tines (B) rest on the ground. The harrow hoist cylinders are then depressurised (A).

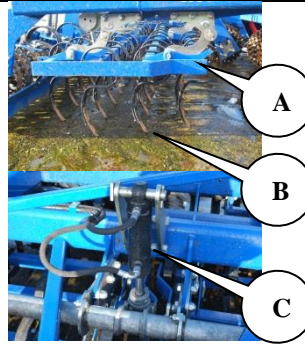

1. Disconnect hoses from cylinder
2. Support cylinder
3. Remove split pins from pins, remove pins
4. Remove cylinder
5. Fit new or repaired cylinder



After fitting, the harrow hoist is actuated until the cylinder shows a slight travel. Reverse cylinder until it returns to start position. Move cylinder backwards and forwards several times.



If cylinder is not bled correctly as described above, there is a risk that part of the machine **can suddenly move much quicker than normal, and before the tractor driver can prevent it.** This is because air (unlike oil) is compressible. A section can therefore swing out very quickly if air bleeding is not performed correctly. This represents a major risk of injury to personnel and of damage to the machine.



Ensure no personnel are within the extension radius of the side sections.

Replacing gaskets on the harrow hoist cylinder

See the section "Replacing gaskets on tilt cylinder"

Replacing the crackerboard cylinder (green)

The machine is extended to the working position, the wheels are raised so that the two cross-kill rollers are resting on the ground. The crackerboard tines (A) are then lowered so that they rest on the ground. The cylinder is then depressurised (B).

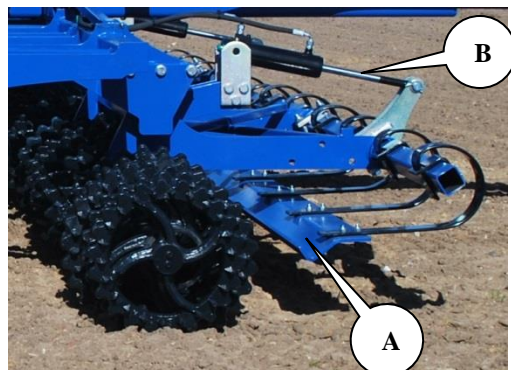

1. Disconnect hoses from cylinder
2. Support cylinder
3. Remove split pins from pins, remove pins
4. Remove cylinder
5. Fit new or repaired cylinder



After fitting, the harrow hoist is actuated until the cylinder shows a slight travel. The cylinder is then actuated until it is retracted. Continue this for approx. 30 seconds until the oil circulates in all the series-connected cylinders to the crackerboard.



If cylinder is not bled correctly as described above, there is a risk that part of the machine **can suddenly move much quicker than normal, and before the tractor driver can prevent it.** This is because air (unlike oil) is compressible. A section can therefore swing out very quickly if air bleeding is not performed correctly. This represents a major risk of injury to personnel and of damage to the machine.



Ensure no personnel are within the extension radius of the side sections.

Replacing the gasket set in the crackerboard cylinder

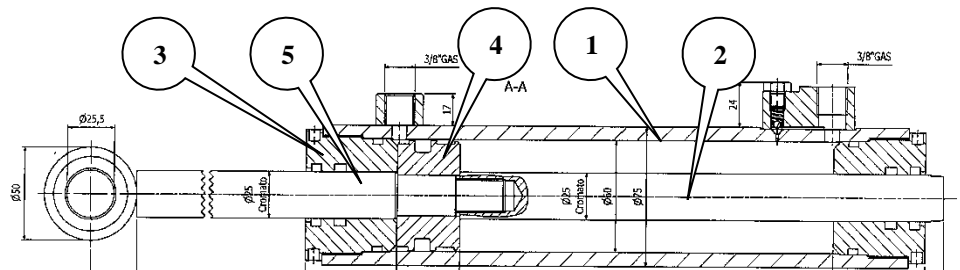

Cylinder 25/60/25-205

- 1 Drain oil from cylinder by moving ram carefully backwards and forwards.
- 2 Extend cylinder halfway. Unscrew and remove upper part [3] from cylinder tube [1]. Use special tool to remove upper part. If upper part is stuck, heat front of upper part. When upper part is detached from cylinder tube, pull ram up towards upper part and remove completely from cylinder tube [1].

- 3 Remove the ram shaft (2) which retains the collar shoe (4).
- 4 Remove collar shoe (4) from ram shaft (5).
- 5 Remove upper part (3) from ram shaft (5).
- 6 Remove gaskets.
- 7 Clean all parts and check for particles etc. Check for rust around scraper ring on upper part. If detected, remove thoroughly.

Assembly

- 1 Fit new gaskets in upper part and collar shoe.
- 2 Apply oil or grease to thread in upper part (3) and cylinder tube (1).
- 3 Fit upper part (3) on ram shaft.
- 4 Mount collar shoe (4) and the ram shaft (2) is **secured with Loctite**. Ensure that thread is absolutely clean and free of oil or other impurities before applying Loctite.
Do not fill with oil for 12 hours after use of Loctite.
- 5 Lubricate outer collar shoe gasket in contact with cylinder tube and inside of cylinder tube with oil, push ram into centre position.
- 6 Fit upper part onto cylinder tube and tighten.
- 7 For fitting cylinder see "**Fejl! Henvisningskilde ikke fundet.**".

Removal/fitting wheel

Before removing wheel, fully extend the machine to the working position with rings resting on ground. Wheels can then be raised off the ground.
Remove wheel nuts. Remove wheel. Replace wheel, hand-tighten wheel nuts. Lower wheels to ground. Tighten wheel nuts to 3000 Nm.

Ensure wheel nuts and wheel surfaces are clean to prevent nuts loosening.



Replacing rollers

Repairs must be performed with the machine connected to a tractor, resting on a level surface, with the weight supported by the transport wheels.
This requires lifting gear, which can lift at least 1200 kg.



1. Slacken bolts (A) without entirely removing nuts.
2. This is attach to the middle cross-kill ring (B) and the strap is tightened until the bolts (A) are loose and can be removed along with the counterplate (C).
3. The a es is then lowered so that the ring (B) rests on the ground.

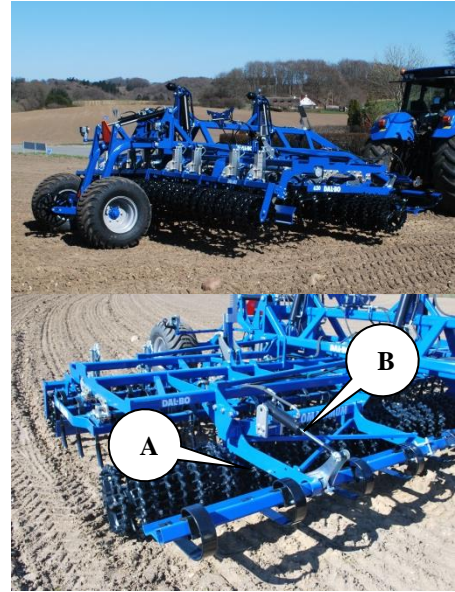

Assembly

Assembly is in the reverse order to dismantling.

Be aware, that you work with very heavy weighing parts.



Do not activate hydraulics if persons are within machine extension radius.

Hydraulic diagram



Rollomaximum 620

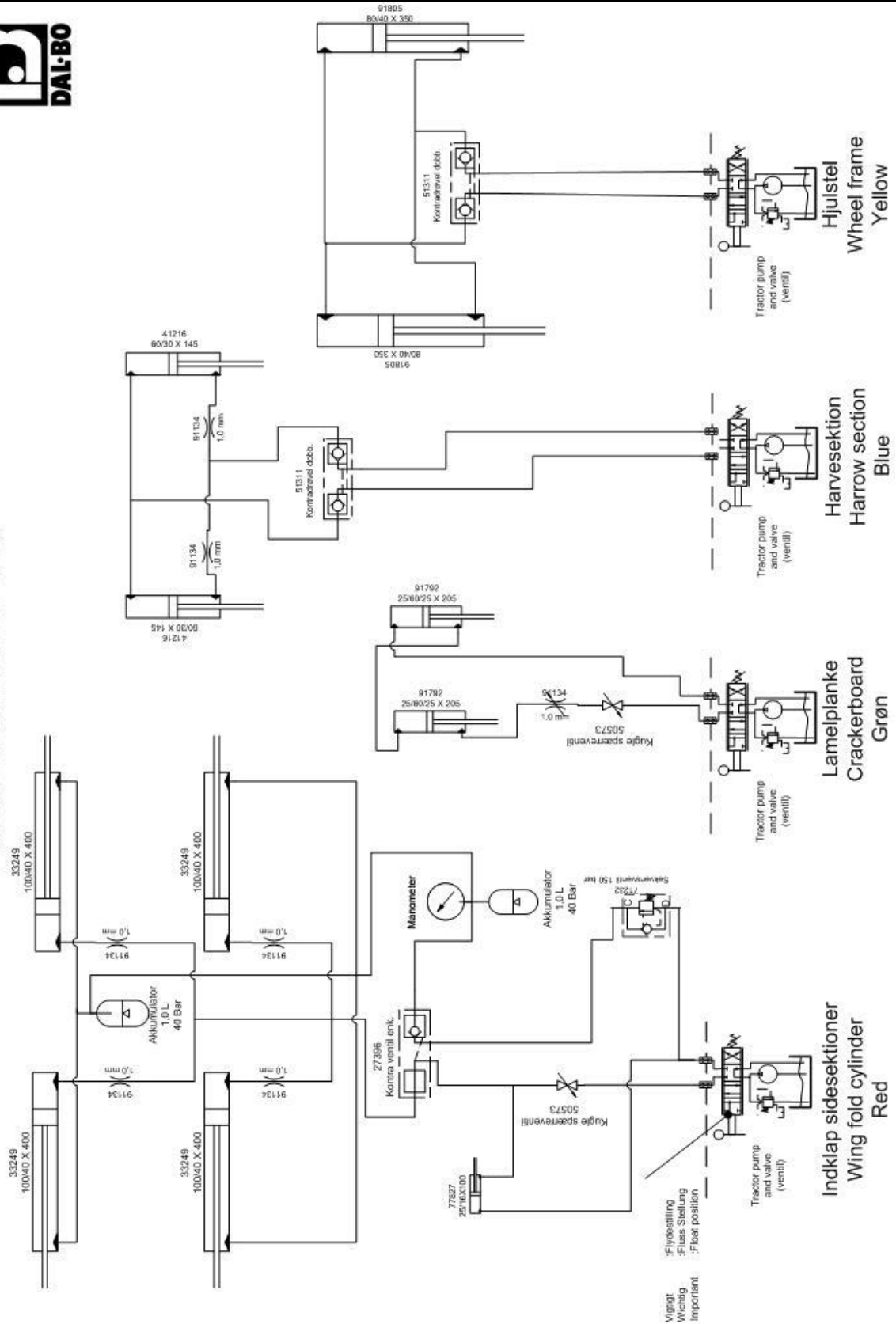

Garantie

DALBO A/S provides a 1 year guarantee on all new machines sold by an authorised DALBO dealer. The guarantee applies for 1 year from the date of delivery to the end-user.

The guarantee covers the remedying of material or manufacturing defects.

The guarantee will lapse in the following instances:

- **The machine is used for purposes other than those described in the user guide.**
- **The machine is abused or treated with neglect**
- **Damage arising from incorrect setting of the machine**
- **Lack of maintenance**
- **Accidental circumstances such as weather, falling objects etc.**
- **Transport damage**
- **Unauthorised repair**
- **Modifications without the written consent of DALBO A/S**
- **Non-original spare parts used.**

DALBO A/S cannot be held liable for consequential damage, loss of earnings or profit or as a result of defects. DALBO A/S cannot be held liable for labour costs other than those reasonably incurred for repairs or the replacement of parts covered by the guarantee.

DALBO A/S cannot be held liable for the following costs:

- **Setting up the machine**
- **The costs of normal maintenance, washing, lubrication or replacement of wearing parts**
- **Transport of the machine to and from a repair workshop**
- **The dealer's costs, such as transport of personnel or parts to and from the machine and/or the repair workshop.**

The following aspects have decisive influence on the guarantee:

- **The guarantee will lapse if the dealer has not prepared the machine, and instructed the user in its use.**

Scrapping



The machine should be extended and lowered to the ground. It is essential that **all** cylinders are depressurised.



Beware of the weight of any given part when removing or disassembling. All parts **must** be supported or lifted to avoid danger of falling.

Disconnect hydraulic hoses and cylinders and drain oil. Collect oil in container to avoid pollution. Send oil and hoses for safe disposal.

All iron used in the machine can be recycled.

Spare parts