

DALBO®

MAXIROLL



EN
1030 – 1230
Serial no.: 100-XXX

MADE IN **D**ENMARK

MAXIROLL

Type 1030 - 1230

Congratulations on the purchase of your new MAXIROLL. For **safety reasons** and to achieve optimum service from the product, please read the User Guide **before use**.

©Copyright 2002. All rights reserved, DALBO A/S

Your MAXIROLL has:

Type no.: _____ Serial no.: _____
Month of manufacture: _____ Net weight kg: _____

If contacting the manufacturer regarding spare parts or service, please state type and serial number. A spare parts list is included at the back of this manual.

EU DECLARATION OF COMPLIANCE

DALBO A/S
DK-7183 Randbøl
+4575883500

declares herewith that the above machine is manufactured in accordance with the provisions of directive 2006/42/EC, which replaced directive 98/37/EC and change directives 91/368/ECC, 93/44/ECC and 93/68/ECC on harmonization of member state legislation concerning health and safety requirements related to the construction and manufacture of machines.



This machine corresponds to the safety requirements in the European Safety Guidelines.

DALBO A/S

Date: _____

Alessio Riulini, CEO

Table of Contents

SAFETY	6
GENERAL	6
HYDRAULICS.....	7
MOUNTING.....	7
MAINTENANCE AND REPAIR	7
ROAD TRANSPORT	7
CORRECT USE.....	8
TECHNICAL DATA	9
HOW TO USE THIS MANUAL.....	10
DELIVERY	10
USES	11
CONNECTING AND DISCONNECTING	12
CONNECTING	12
HYDRAULICS.....	12
DISCONNECTION	12
SETTING UP.....	13
ADJUSTING DRAWBAR HEIGHT	13
OPERATION	14
EXTENDING AND FOLDING UP	14
<i>Extending</i>	14
<i>Fold up</i>	15
ADJUSTMENT OF HYDRAULIC WEIGHT TRANSFER	16
<i>Excessive pressure</i>	16
<i>Insufficient pressure</i>	16
OPERATING SPEED	17
ADJUSTMENT OF HYDRAULIC SUSPENSION OF PENDULUM FRAMES	17
<i>Excessive pressure</i>	18
<i>Insufficient pressure</i>	18
TIRE PRESSURE	18
TROUBLESHOOTING	19
ACCESSORIES.....	20
CRACKERBOARD.....	20
<i>Power</i>	20
<i>Hose markings</i>	21
<i>Adjusting angle of teeth</i>	21
<i>Operation</i>	22
<i>Retrofitting</i>	22
<i>Locking set</i>	23

MAINTENANCE.....	24
LUBRICATION	24
ADJUSTMENT	24
<i>Adjustment of rollers</i>	25
<i>Wheels</i>	25
<i>Wear parts</i>	25
HYDRAULICS.....	26
REPLACEMENT AND REPAIRS.....	27
HYDRAULICS.....	27
<i>Replacing extend cylinder for folding side sections</i>	27
<i>Replacing gaskets for side section fold/unfold</i>	28
<i>Mounting</i>	29
<i>Replacing raise/lower cylinder on main frame</i>	29
<i>Replacing gaskets on raise/lower cylinder</i>	30
<i>Mounting</i>	30
<i>Replacing pendulum frame suspension cylinder</i>	31
<i>Replacing gasket set for suspension</i>	31
<i>Replacing crackerboard depth-adjustment cylinder</i>	32
<i>Replacing gasket set for depth adjustment</i>	32
REMOVAL/FITTING WHEEL	33
<i>Replacing wheel bearings</i>	33
REMOVING ROLLER AXLES	34
<i>Replacing axles</i>	34
<i>Fitting axles with roller rings</i>	35
REPLACING AXLES, BEARINGS OR ROLLER RINGS	35
<i>Crosskill ring</i>	35
SCRAPPING	37
HYDRAULIC DIAGRAM	38
SPARE PARTS	42

Safety



This symbol appears in the instruction manual each time there is a safety warning concerning your safety, the safety of others or functionality of the machine. All safety instructions must be observed and made available to all users of the machine.

General

- Ensure you are familiar with all aspects of the machine before use
- There are safety stickers on the machine containing important instructions for the safety of yourself and others, and correct use of the machine.
- Do not carry passengers during operation or transport.
- Ensure there are no personnel within the machine's working radius before operating. Operate machine only from inside the tractor.
- When roller is folded together, check the side sections are locked. Check all control handles are secured against accidental operation.
- Before leaving the tractor or making adjustments, performing maintenance or repairs on the roller, extend fully and lower to ground, or maintain in transport position, apply tractor handbrake, switch engine off and remove ignition key to secure the machine against accidental operation.
- Remember to secure support legs and pins with split rings.
- Never leave driver's seat whilst machine is moving.
- Always adapt speed to conditions.
- Do not use machine unless all safety devices are in place. Defective safety devices must be replaced immediately.

Hydraulics

- Lower machine fully for any repair work on the hydraulic system. Relieve hydraulic pressure, switch engine off and remove ignition key.
- Clean hydraulic connections thoroughly before reconnecting. When connecting hydraulic hoses to tractor hydraulics, ensure they are not under pressure.
- Bleed the hydraulic system thoroughly after any repairs.
- Check hydraulic hoses regularly for defects such as cracks, splits, crimps, wear or breaks. Defective hoses must be replaced immediately.
- Avoid spilling oil on the ground. If oil is spilt, collect and deliver to a destruction point.
- Clean hands thoroughly after contact with oil and grease. Change oil-stained clothing immediately. Hydraulic oil can be harmful to the skin.
- Hydraulic oil released under high pressure can penetrate the skin and cause severe injury. In the event of injury, seek medical help immediately.

Mounting

- Danger of crushing! Ensure no personnel are between implement and tractor, or between the parts to be connected.

Maintenance and repair

- Ensure machine is adequately supported or fully extended for all repair and maintenance work. Ensure tractor and machine are properly braked, engine stopped and ignition key removed.
- Tighten all screw connections after a few hours use. Check all screw connections regularly and tighten as required. Check all split pins and bolts to avoid mechanical failure.
- Dispose of oil, grease and filters in accordance with local environmental protection rules.

Road transport

- All safety and warning precautions mandatory by law must be fitted and tested before transporting the machine on public roads. The driver is responsible for correct lighting and warning signs in accordance with traffic regulations.
- Check with local traffic authorities whether transport on public roads is allowed given the machine's dimensions.

- When transporting, ensure permitted total weight for tractor is not exceeded and that loading on tractor front axle is not less than 20% of tractor net weight. If this is the case, use weights on tractor front

Correct use

- Correct use of the machine includes observing the manufacturer's operating, maintenance and repair instructions, and that original spare parts are always used.
- MAXIROLL may only be used, maintained or repaired by personnel familiar with it and who are aware of the risks that can be involved.
- The manufacturer cannot be held liable for injury or damage arising from modifications made to the machine performed without prior permission from the manufacturer. Neither can the manufacturer be held liable for injury or damage arising from incorrect use. Such liability rests solely with the user.
- Do not add extra weight to the roller.

Technical data

MAXIROLL

Size (cm)	1030	1230
HP (recommended)	200+	350+*
Gross weight kg:		
Cambridge 50	7590	*
Cambridge 55	8415	*
Cambridge 60	9550	-
Crosskill 53	6320	*
Crosskill 60	7750	*
Sections (pcs.)		
	5	
Wheels		
	520/50-17	710/40-22,5
Hydraulic requirements:		
DV	3	
EV	0	
Accessories		
Wheels	600/50-22.5	-
Crackerboard (kg)	1200	1300*
Requires DV hydr.	1	

*MAXIROLL 1230 has standard crackerboard fitted.

The table below indicates oil capacity.

Model	Oil (litres)
1030	Approx. 35 Litres
1230	Approx. 58 Litres

How to use this manual

The sequence of subject matter in this manual can seem illogical. Please refer to the table of contents for page numbers for individual items.

The manual is divided into 5 main sections:

- Safety
- Starting routine and running
- Accessories
- Maintenance
- Repairs

The following symbols represent:



Points which are important to functionality and service life.



Points relevant to safety.

Delivery

The roller is delivered complete on a trailer.

If lifting the roller, we recommend the use of straps on the mid-section and drawbar to maintain balance. Lifting points are marked on the machine.

Uses

MAXIROLL is an extra-heavy roller designed specifically for the mounting of extra equipment for soil preparation.

MAXIROLL 1030 and 1230 are 5-piece rollers with independent sections. Hydraulic weight transfer and stone protection is standard for both models.

Fig. 1



MAXIROLL, 1030

MAXIROLL is used prior to sowing to crush lumps and afterwards to prepare for shooting and to break down stones. MAXIROLL can also be used for breaking up a compressed soil surface in wheat fields or grassed areas.

Can be fitted with accessories, such as hydraulic crackerboard. The main purpose of the crackerboard is preparation for sowing. The vibrating effect of the teeth breaks up lumps, preparing and levelling ploughed and pre-prepared fields. If the crackerboard is not required, it can be raised and MAXIROLL used exclusively as a roller.

Connecting and disconnecting

Connecting

Connect roller to the tractor's fixed towbar, where drawbar (A) must fit between the towbar forks.

Insert pin and remove leg.

Fig.2



Hydraulics

Remember to secure towbar pin with split pin or the like.

MAXIROLL requires a standard double-acting hydraulic outlet with flow setting. One of the double-acting outlets is for unfolding the side sections and the other for raising/lowering the roller.

Table 1. Hose markings

Cylinder name	Colour	Outlet	Function
Raise/lower cylinder	White	Double acting	Raises MAXIROLL up onto its wheels and down into working position.
Fold/weight equalisation	Red	Double acting	Folds side sections up/out and acts as weight equalisation from mid-section to side sections.
Suspension	Blue	Single acting	For suspension of pendulum frames in conjunction with the accumulators to absorb shock on the frames.



Flow setting is required for both double-acting outlets.

Check hydraulic hoses for crimping

Disconnection

Fit leg, remove towing pin and disconnect hydraulic hoses.



Remember to depressurise hoses before disconnecting them.

MAXIROLL must be in transport or working position when disconnecting.

Setting up

MAXIROLL is supplied with factory settings, but fine adjustment will always be required before use. Numerous adjustment options make the roller more flexible and ensure maximum use.

Adjusting drawbar height

To achieve uniform field compression, the machine's drawbar must be horizontal in working position. Adjustment can be necessary, depending on tractor.



Incorrect drawbar height can cause uneven operation, as the roller will not apply equal pressure for all sections.

To achieve optimum drawbar height, the drawbar can be turned or adjusted up/down until the eye fits the tractor towbar.

Stand MAXIROLL on support leg. Slacken bolts (A) and adjust drawbar to tractor.

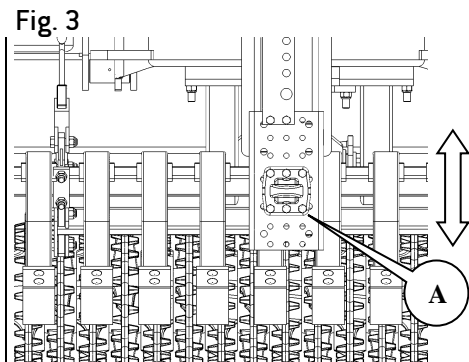

Operation

Correct operation is vital to get the best out of your MAXIROLL 1030 or 1230. This applies to field use and safety. Always ensure you are fully familiar with all safety aspects of the machine.

Extending and folding up

Extending and folding the machine up must always be performed with tractor parked.



Before extension and folding, check crackerboard is fully raised to avoid teeth colliding (see "Accessories, Crackerboard")

Extending

- 1 Side sections are lifted from the transport bar (A) using raise/lower cylinder (marked: White).

Fig. 4

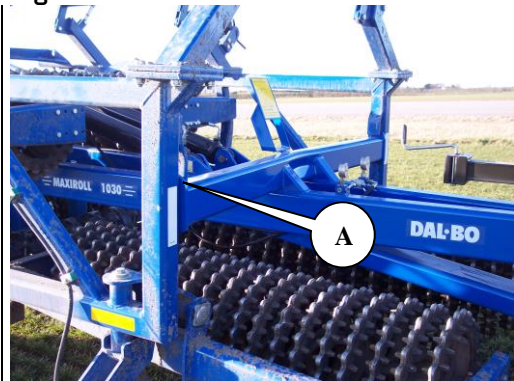

- 2 Activate extend/retract cylinders (marked: Red) to fully extend side sections.
- 3 Activate raise/lower cylinders to lower roller to ground. **While the roller is getting lower is it very important, that the two outer shafts and the middle shaft are hitting the ground exactly at the same time, so the middle section won't get overloaded.** Set raise/lower cylinder to flow setting last.

Fig. 5



Before starting rolling, ensure weight transfer is correctly adjusted (see "Adjustment of hydraulic weight transfer").



Fold up

If there is a crackerboard fitted, check it is fully raised before starting folding (see "Accessories, Crackerboard, Operation")

1. Activate extend/retract cylinders (marked: Red) to lift end of side sections (A) a little.

Fig. 6



2. Activate raise/lower cylinder (marked: White) to full length. Roller will lift from ground.

Fig. 7



3. Activate extend/retract cylinders to fold side sections in.

4. Activate raise/lower cylinder to lower roller into transport bar. (See fig. 5)

Fig. 8

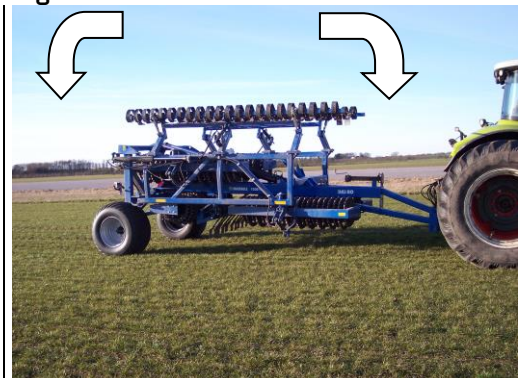

Adjustment of hydraulic weight transfer

Hydraulic weight transfer distributes the weight evenly between all roller sections.

1. Once the roller is unfolded, relieve pressure in the extend/retract cylinders (marked: Red), and activate cylinder control handle in the opposite direction.

2. After short delay the manometer will react. Increase pressure to approx. 15 bar (A). This will transfer some of the mid-section weight to the side sections.

Fig. 9

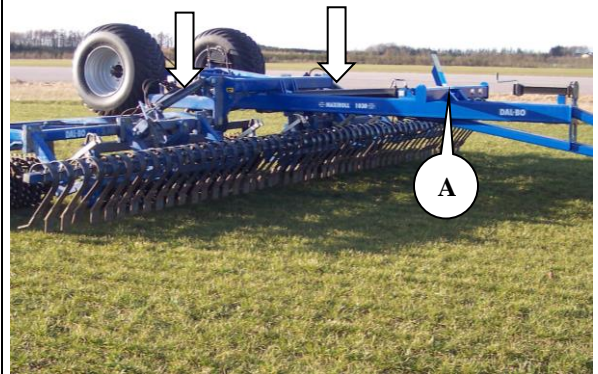

3. Set control handle to flow setting. Flow setting is necessary to achieve hydraulic weight transfer, allowing the sections to move independently
4. The pressure for hydraulic weight transfer may need adjustment. It can also be necessary to adjust pressure according to soil conditions.

Excessive pressure

1. Pressure on the side sections will be too great, leaving clear tracks in the soil.
2. The mid-sections will not apply sufficient pressure, leaving the soil higher and not as compressed as the sides.

Insufficient pressure

1. The pressure on the extremities of the side sections will be insufficient to give uniform compression.
2. The mid-sections will compress too much, leaving the soil lower than the sides.



To prolong service life and the final result in the field, MAXIROLL must be set in **flow setting** when working in the field.



Failure to do so is incorrect use and can cause the frame to break in the worst scenario.

Operating speed

An operating speed of 6-10 km/h is recommended, but always operate according to conditions.

Increased speed will increase wear, particularly in dry conditions. The rings can also be damaged if operating at excessive speeds in unfavourable conditions.

Adjustment of hydraulic suspension of pendulum frames

Hydraulic weight transfer distributes the weight evenly between all roller sections. Pressure on the pendulum frames must therefore also be uniform!

- 1 Once the roller is unfolded and adjusted for the correct pressure and flow setting, adjust the suspension pressure.

- 2 Cylinder (A) is fitted on all 5 pendulum frames, to absorb impact from large stones.

Fig. 11



- 3 Manometer (B) is fitted on top of the machine for the operator to monitor pressure. Cock (C) is fitted for easy adjustment of pressure. Adjust cock until the correct pressure is achieved with the tractor hydraulics in flow setting. We recommend 70 bar. If additional pressure is required, keep the cock open and use the tractor hydraulics to increase pressure.

Fig. 12

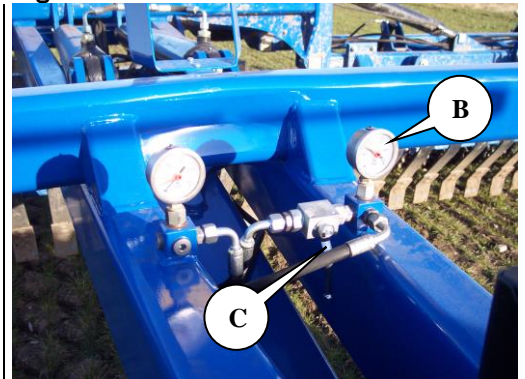

- 3 The pressure for hydraulic suspension may need adjustment. It can also be necessary to adjust pressure according to soil conditions.

Excessive pressure

- 1 If the cylinder does not move, pressure is too great. This can cause excessive strain on the frames.
- 2 Reduce pressure until the cylinder moves again.

Insufficient pressure

- 1 Pressure is too low if the cylinder cannot extend fully.
- 2 Adjust (increase) pressure until all 5 suspension cylinders extend.



**We recommend running at a pressure of 70 bar!
But always operate according to conditions!**

Tire pressure

The tables below show the load, speed and tire pressure in relation to each other at the different tire combinations.

700/40-22,5 Alliance

700/40-22.5	24.00DC	700	1170	510	3486	16PR	2	4510	3830	3220	2900	6370	5410	4550	4100
						166A8⊕	2.2	4760	4050	3400	3060	6730	5720	4810	4330
						162B⊕	2.6	5250	4460	3750	3380	7420	6310	5300	4770
						154A8○									
						150B○	3.6	7510	6380	5360	4830	8900	7570	6360	5720

Troubleshooting

Fault	Cause	Remedy
Mid-section applying too much pressure	<ul style="list-style-type: none"> • Insufficient pressure transferred to side sections 	<ul style="list-style-type: none"> • Activate hydraulic control handle for extend/retract to increase pressure to side sections (see "Operation").
	<ul style="list-style-type: none"> • Drawbar too high 	<ul style="list-style-type: none"> • Adjust drawbar and mid-section (see "Adjusting drawbar height" page 13.
	<ul style="list-style-type: none"> • Mid-section not horizontal 	<ul style="list-style-type: none"> • Adjust drawbar and mid-section (see "Adjusting drawbar height" page 13.
Side section extremities applying too much pressure	<ul style="list-style-type: none"> • Insufficient pressure in mid-section 	<ul style="list-style-type: none"> • Activate hydraulic control handle for extend/retract to increase pressure to mid-section (see "Operation").
	<ul style="list-style-type: none"> • Drawbar too low 	<ul style="list-style-type: none"> • Adjust drawbar and mid-section (see "Adjusting drawbar height" page 13.
	<ul style="list-style-type: none"> • Mid-section not horizontal 	<ul style="list-style-type: none"> • Adjust drawbar and mid-section (see "Adjusting drawbar height" page 13.
Pressure on manometer dropping	<ul style="list-style-type: none"> • Handle not in flow setting 	<ul style="list-style-type: none"> • Adjust pressure on weight transfer and set handle to flow setting (see "Adjustment of hydraulic weight transfer")
	<ul style="list-style-type: none"> • Driver-operated non-return valve defective • Cylinder (gasket set) leaking 	<ul style="list-style-type: none"> • Set weight transfer to 15 bar, set handle to flow setting. Leave MAXIROLL standing for 30 mins. If pressure drops, the driver-operated non-return valve is defective, or there may be dirt in the valve (disassemble valve and clean parts)
Side sections not following terrain	<ul style="list-style-type: none"> • Weight transfer hydraulic system not in flow setting 	<ul style="list-style-type: none"> • Set hydraulic weight transfer in flow setting (see "Adjustment of hydraulic weight transfer")

Accessories

MAXIROLL can be fitted with a range of accessories to suit requirements.

- Crackerboard with curved wear parts.
- Crackerboard with crust-breakers.
- Rake.
- Large wheels.

Crackerboard

The major benefit of the board is that the teeth can move individually, and flex when meeting local resistance. This provides a big advantage compared to a levelling board, avoiding having to raise the entire arm in the event of it meeting an obstacle.

Fig. 13



Power

Compared to a fixed levelling board, a crackerboard does not require so much power, although this can vary depending on how the board is used.

Table 3. Crackerboard power requirements in HP

1030
100+

*MAXIROLL 1230 is fitted as standard with a crackerboard.



By moving the minimum amount of soil, fuel consumption is reduced significantly along with wear and tear.

Hose markings

Table 4. Hose markings

Cylinder name	Colour	Outlet	Function
Depth adjustment	Green	Double acting	Adjust crackerboard depth.

Adjusting angle of teeth

Crackerboard depth is hydraulically adjustable. The angle of the teeth is adjusted manually on the spindles (A). To ensure uniform crackerboard angle setting, there are numbers on the sides of the spindles.

The angle set will be retained regardless of depth, as the teeth are mounted in a parallelogram.

Fig. 14



- For an **aggressive tooth** (vertical) make the spindles shorter.
- For a **passive tooth** (horizontal) make the spindles longer.



Raise crackerboard to highest position for adjustment of teeth angle.

The angle of the teeth depends on the nature of the job. If they are set aggressively while the depth is set for the upper soil layer, maximum vibration will be created for fine-crushing of lumps. This setting is recommended for most jobs.

If the teeth are more horizontal, it will allow them to avoid obstacles. It will also mean that the tips of the teeth can move more in the vertical plane, leaving an uneven field

Operation

The crackerboard is a flexible unit with a range of uses. At depth setting of approx. 5cm, the vibrating effect of the teeth will crush clumps.

A deeper setting will increase the levelling effect to that of a levelling board, as a small bank of soil builds up in front of the teeth.

Fig. 15



Its function is **not** as a dozer blade, but to break the soil down. As each tooth can move individually and thus yield to local pressure, the crackerboard is easy to use and requires little adjustment compared to a levelling board.



The board sections can run at different depths which means it may be necessary to reset the board by raising it to full height.

Retrofitting

The crackerboard can be factory-fitted, or supplied at a later date if required. A crane or other lifting device will be required for retrofitting.

- 1 MAXIROLL unfolded.
- 2 Mid-section mounted on flanges (A).

Fig. 16

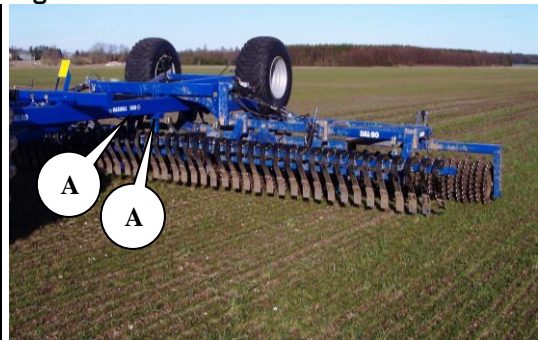

- 3 Side sections mounted on flanges (B).
- 4 Fit hydraulic cylinders.
- 5 Fit hoses on cylinders.

Fig. 17

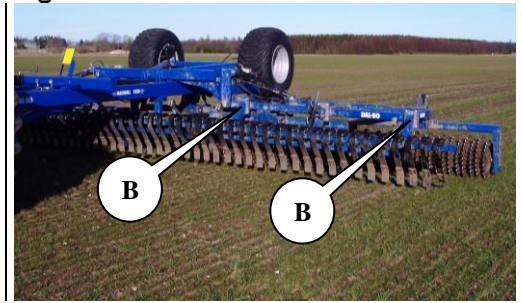

- 6 Secure hoses in hose holders (C) and pass through holders on drawbar.
- 7 Tighten all fittings securely. Connect board to tractor hydraulics.

Fig. 18

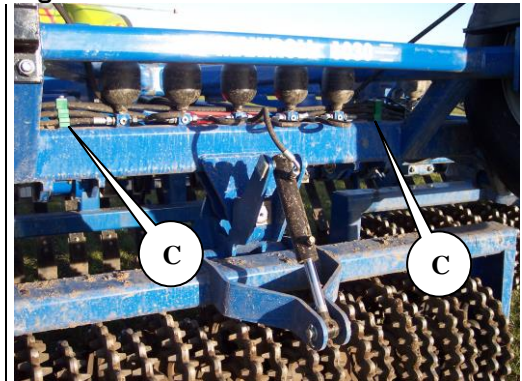

Bleed system thoroughly to avoid injury to personnel. Extend depth adjustment cylinders fully several times.

Locking set

A crackerboard locking set is available as an accessory to lock the teeth into one long board in three sections. The crackerboard will then act more like a levelling board

Mounting

The locking set is mounted on the back of the teeth (see illustration) using longer bolts on the wear parts. The teeth are linked by an iron bar (A), secured by pins (B).

Fig. 19

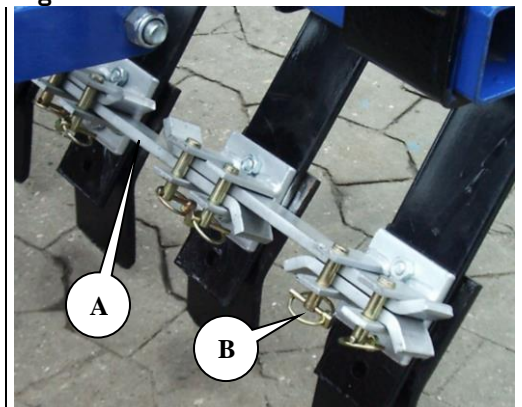

Maintenance

Good maintenance ensures long service life and optimum use. Grease nipples are fitted where wear is heaviest.



Tighten all screw connections after first working day. Check all split pins and bolts to avoid mechanical failure. Check hydraulic system for leaks.

Lubrication

Fig. 20

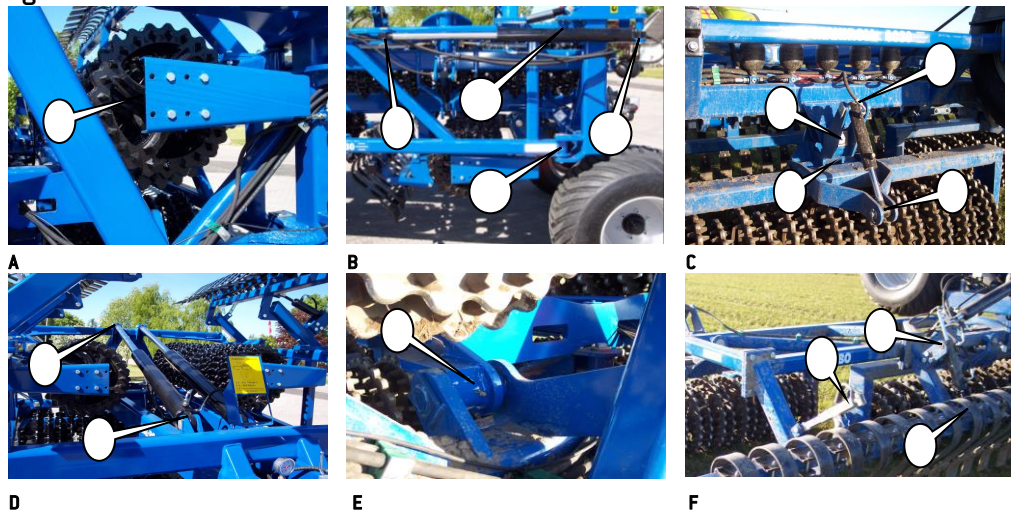

Lubrication points	Number of nipples	Lubrication intervals, hours	Illustration
Flange bearings	10	50	A
Cylinder for extending side sections	4	50	B
Rotation pin for extending side sections	4	50	B
Pendulum frame and suspension	10	50	C
Cylinder for suspension/stone protection	10	50	C
Raise/lower cylinder	4	50	D
Rotation pin for raise/lower	2	50	E
Crackerboard cylinder	15	50	F
Crackerboard spindle	6	100	F
Wheel bearings	2	200	



Lubricate all lubrication points at least once annually.

Adjustment

Adjustment of rollers

After the first season, the rollers will have loosened on the shaft. Play can be eliminated by moving the stop rings on the shaft.

Adjustment is easiest when MAXIROLL is folded together.

1. Slacken bolts (A) and push rollers together
2. Tighten and slacken stop ring bolts at the same place on the shaft several times to ensure they bite firmly into the shaft.

Fig. 21

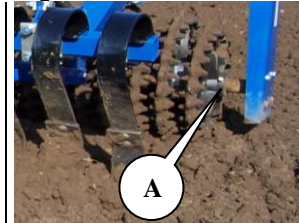

Wheels

Lubricate and adjust wheel bearings at least once annually. Check tyre pressures at least once annually (see recommended pressure on tyre).

Adjustment and lubrication of wheel bearings

1. Remove hub caps.
2. Remove split pin.
3. Tighten castle nut 1/6th of a turn until hole aligns with axle. Turn wheel, check for resistance. A little play should be detected in the hub housing when rocking wheel from side to side. If play is excessive, repeat process.
4. Replace split pin
5. Fill hub cap $3/4$ full with grease. Replace.

Wear parts

Wear parts (shoes) are factory-mounted in the upper holes on each tooth. Move down to the lower holes (A) before teeth are worn.

Once they are worn out (when in the lower holes), replace.

Fig. 22

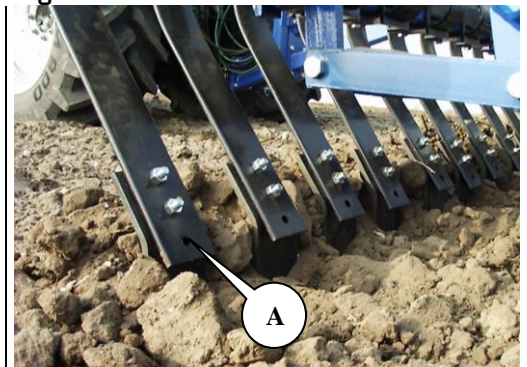

Hydraulics



Check all hydraulic hoses for wear or cracks. Check all hoses for crimping.



Lubricate exposed rams with oil or pressure-resistant grease to avoid rust forming when storing for long periods. Remember to remove before use.

Replacement and repairs



Safety is vital for **all** repair work on the roller. Always observe the following points, plus those under Safety First in the instruction manual.



All maintenance and repair work can only be performed when the machine is lowered to the ground or locked in transport position, tractor is braked, engine stopped and ignition key removed to prevent accidental start.



Particular attention must be paid to safety when repairing hydraulics. Before commencing work, depressurise hydraulic system and support part being worked on.



Always ensure hydraulic system is bled after repairs and before use to prevent mechanical breakdown and injury to person.

Hydraulics

Replacing extend cylinder for folding side sections

Roller must be fully extended and standing on ground for repairs.

1. Depressurise cylinders. **Check there is no pressure shown on the manometer**
2. Disconnect hoses.
3. Remove split pins and pins. Cylinder will now be free.
4. Fit new or repaired cylinder. Check pin locks into place, secure pins with split pins.
5. Connect hoses. Check there is no danger of hoses being ripped or crimped after fitting.

Fig. 23





Activate extend/retract cylinders after fitting until they show a little movement. Reverse cylinders until they return to start position. Move cylinders backwards and forward several times. Raise roller fully onto wheels, extend side sections fully to bleed system.



Ensure no personnel are within the extension radius of the side sections.

Replacing gaskets for side section fold/unfold

Fig. 24

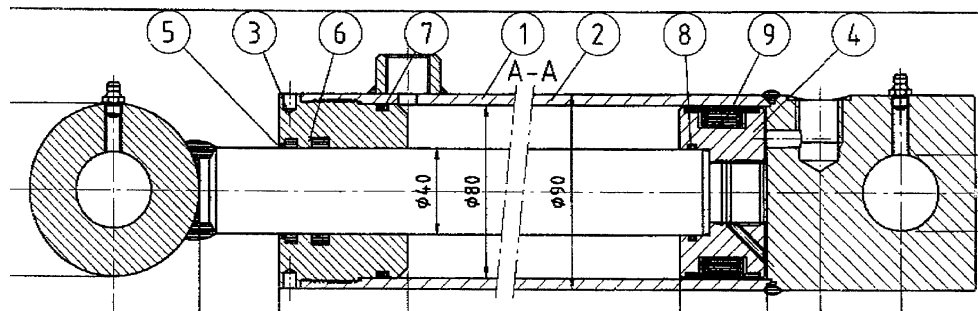

1. For cylinder removal, see "Replacing extend cylinder for folding side sections".
2. Drain oil from cylinder by moving ram carefully backwards and forwards.
3. Extend ram to centre position. Unscrew upper part (pos. 3) from cylinder tube (pos. 1). Use special tool to remove upper part. If upper part is stuck, heat front of sleeve. When upper part is detached from cylinder tube, pull ram up towards upper part and remove completely from cylinder tube.
4. Remove lock nut securing collar shoe (pos. 4).
5. Remove collar shoe (pos. 4) from ram.
6. Remove upper part (pos. 3) from ram.
7. Remove gaskets in upper part and collar shoe, (pos. 5+6+7+8+9).
8. Clean all parts and check for particles etc. Check for rust around scraper ring (pos. 5) in upper part. If detected, remove thoroughly.

Mounting

1. Fit new gaskets (pos. 5+6+7+8+9) in upper part and collar shoe. Remember to check gaskets are facing the right way.
2. Lubricate thread in upper part (pos. 3) with oil.
3. Fit upper part (pos. 3) on ram shaft.
4. Fit collar shoe (pos. 4) and screw on lock nut, **secure with Loctite**. Ensure that thread is absolutely clean and free of oil or other impurities before applying Loctite. **Do not fill with oil for 12 hours after use of Loctite.**
5. Lubricate outer collar shoe gasket in contact with cylinder tube and inside of cylinder tube with oil, push ram into centre position.
6. Fit upper part onto cylinder tube and tighten.
7. Fit cylinder (see "Replacing extend cylinder for folding side sections").

Replacing raise/lower cylinder on main frame

Extend roller and relieve pressure on raise/lower cylinder (A).

Fig. 25

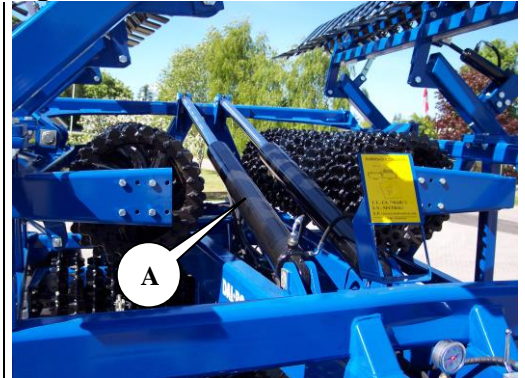

1. Disconnect hoses from cylinder
2. Support cylinder
3. Remove split pins in pins, remove pins
4. Remove cylinder
5. Fit new or repaired cylinder



Activate raise/lower cylinder after fitting until cylinder shows movement. Reverse cylinder until it returns to start position. Move cylinder backwards and forwards several times. Fully extend cylinder several times to bleed system.



Ensure no personnel are within the extension radius of the side sections.

Replacing gaskets on raise/lower cylinder

Fig. 26

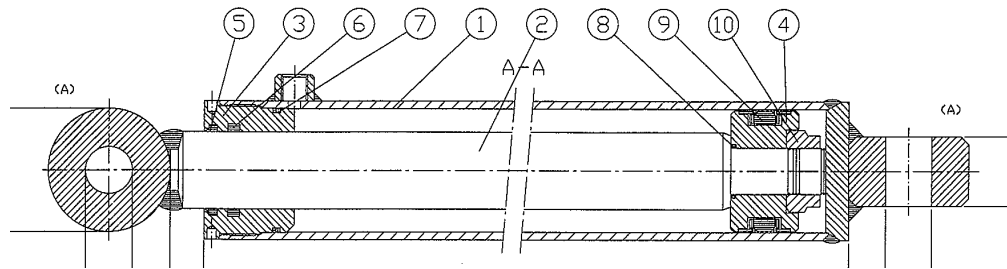

1. Drain oil from cylinder by moving ram carefully backwards and forwards.
2. Extend ram to centre position. Unscrew upper part (pos. 3) from cylinder tube (pos. 1). Use special tool to remove upper part. If upper part is stuck, heat front of upper part gently. When upper part is detached from cylinder tube, pull ram up towards upper part and remove completely from cylinder tube (pos. 1).
3. Remove lock nut (pos. 10) securing collar shoe (pos. 4).
4. Remove collar shoe (pos. 4) from ram shaft, (pos. 2).
5. Remove upper part (pos. 3) from ram shaft, (pos. 2).
6. Remove gaskets in upper part (pos. 5+6+7+8+9) along with collar shoe.
7. Clean all parts and check for particles etc. Check for rust around scraper ring (pos. 5) in upper part. If detected, remove thoroughly.

Mounting

1. Fit new gaskets (pos. 5+6+7+8+9) in upper part, plus collar shoe.
2. Lubricate thread in upper part (pos. 3) and cylinder tube (pos. 1) with oil.
3. Fit upper part (pos. 3) on ram shaft.
4. Fit collar shoe (pos. 4) and screw on lock nut, **secure with Loctite**. Ensure that thread is absolutely clean and free of oil or other impurities before applying Loctite. **Do not fill with oil for 12 hours after use of Loctite.**
5. Lubricate outer collar shoe gasket in contact with cylinder tube and inside of cylinder tube with oil, push ram into centre position.
6. Fit upper part onto cylinder tube and tighten.
7. For fitting cylinder see "Replacing raise/lower cylinder".

Replacing pendulum frame suspension cylinder

Fig. 27

1. Extend roller resting on a level surface
2. Set tractor hydraulic control handle in flow setting. Set manometer handle in flow setting. Pressure will flow back into the tractor.
3. Disconnect hoses from cylinders
4. Remove split pins and pins (B)
5. Fit new or repaired cylinder (A)
6. Remember to replace split pins in pins

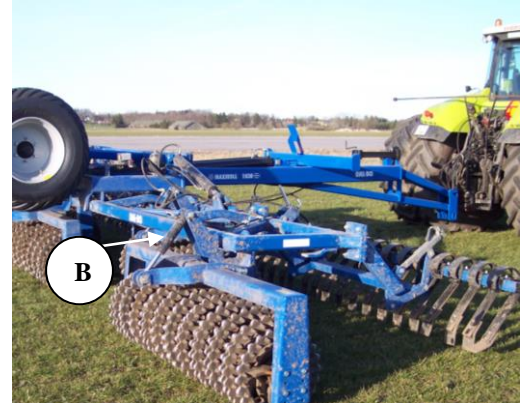

Activate depth-adjustment cylinders up and down a few times after fitting and with roller extended, to bleed system.

Replacing gasket set for suspension

Fig. 28

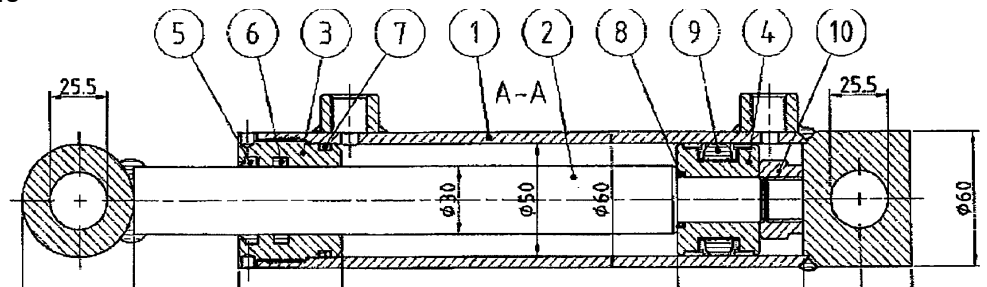

Cylinder 50/30-150

- 1 Drain oil from cylinder by moving ram carefully backwards and forwards.
- 2 Extend ram to centre position. Unscrew upper part (pos. 3) from cylinder tube (pos. 1). Use special tool to remove upper part. If upper part is stuck, heat front of upper part. When upper part is detached from cylinder tube, pull ram up towards upper part and remove completely from cylinder tube (pos. 1).
- 3 Remove lock nut (pos. 10) securing collar shoe (pos. 4).
- 4 Remove collar shoe (pos. 4) from ram shaft, (pos. 2).
- 5 Remove upper part (pos. 3) from ram shaft, (pos. 2).
- 6 Remove gaskets in upper part (pos. 5+6+7+8+9) along with collar shoe.

Replacing crackerboard depth-adjustment cylinder

Fig. 29

7. Extend roller resting on a level surface
8. Lower board, depressurise hydraulic system
9. Disconnect hoses from cylinders
10. Remove bolts, split pins and pins (B)
11. Fit new or repaired cylinder (A)
12. Remember to replace split pins in pins

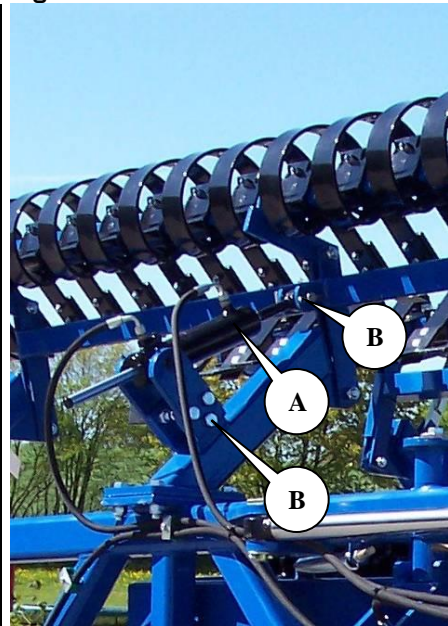

Activate depth-adjustment cylinders up and down a few times after fitting and with roller extended, to bleed system.

Replacing gasket set for depth adjustment

Fig. 30

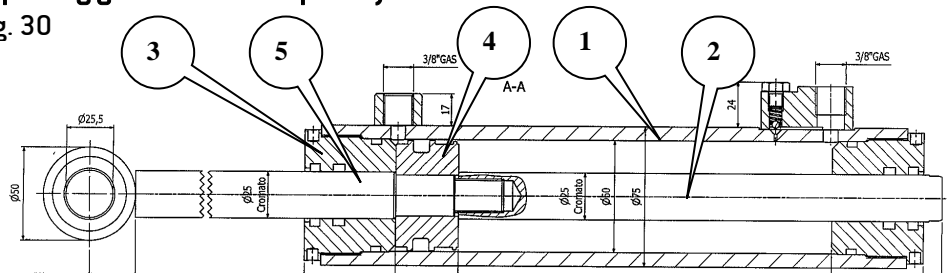

Cylinder 25/60/25-205

- 7 Drain oil from cylinder by moving ram carefully backwards and forwards.
- 8 Extend ram to centre position. Unscrew upper part (pos. 3) from cylinder tube (pos. 1). Use special tool to remove upper part. If upper part is stuck, heat front of upper part. When upper part is detached from cylinder tube, pull ram up towards upper part and remove completely from cylinder tube (pos. 1).
- 9 Remove ram shaft (pos. 2) securing collar shoe (pos. 4).
- 10 Remove collar shoe (pos. 4) from ram shaft, (pos. 5).
- 11 Remove upper part (pos. 3) from ram shaft, (pos. 5).
- 12 Remove gaskets.
- 13 Clean all parts and check for particles etc. Check for rust around scraper ring on upper part. If detected, remove thoroughly.

Mounting

- 1 Fit new gaskets in upper part and collar shoe.
- 2 Lubricate thread in upper part (pos. 3) and cylinder tube (pos. 1) with grease or oil.
- 3 Fit upper part (pos. 3) on ram shaft.
- 4 Fit collar shoe (pos. 4) and secure ram shaft (pos. 2) **with Loctite**. Ensure that thread is absolutely clean and free of oil or other impurities before applying Loctite. **Do not fill with oil for 12 hours after use of Loctite.**
- 5 Lubricate outer collar shoe gasket in contact with cylinder tube and inside of cylinder tube with oil, push ram into centre position.
- 6 Fit upper part onto cylinder tube and tighten.
- 7 For fitting cylinder see "Replacing crackerboard depth-adjustment cylinder".

Removal/fitting wheel

Before removing wheel, fully extend roller with rings resting on ground. Wheels will then be raised free of ground.

Remove wheel nuts. Remove wheel. Replace wheel, hand-tighten wheel nuts. Lower wheels to ground. Tighten wheel nuts to 300 Nm.



Ensure wheel nuts and wheel surfaces are clean to avoid nuts loosening.

Replacing wheel bearings

1. Remove hub cap pos. 21.
2. Remove split pin pos. 20.
3. Remove castle nut pos. 19.
4. Hub housing can now be removed from shaft.
5. Remove bearings pos. 17+18.
6. Remove seal ring pos. 19.

Fig. 31

FL55-6

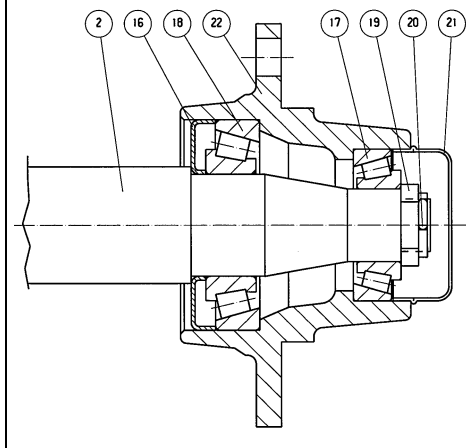

Mounting

1. Fit bearing outer rings pos. 17+18 in hub housing pos. 22
2. Fit seal ring pos. 16.

3. Fit bearing inner ring pos. 18 on axle pos. 2 and fit axle in hub housing
4. Fit bearing inner ring pos. 17 on axle pos. 2

5. Screw castle nut onto axle pos 2, whilst turning hub housing pos. 22. Tighten castle nut until hub housing revolves slowly. Slacken castle nut a quarter turn or until hub housing revolves easily.
6. Fit split pin pos. 20.
7. Fill hub cap pos. 21 half full with ball bearing grease and fit hub cap.

Removing roller axles

Repairs must be performed with the roller connected to a tractor, resting on a level surface, fully extended with the rings resting on the ground. A crane is recommended for removal and replacement procedures.

Replacing axles

When replacing an axle on a side frame, the opposing axle on the other side section must be removed to avoid tipping the roller over.



1. Extend machine to working position.
2. Slacken bolts (A)
3. Activate raise/lower cylinder until bolts (A) are loose and can be removed.
4. Activate raise/lower cylinder again to lift roller on to its wheels
5. Roll axle with roller rings from roller. (If this is the centre axle, lift sideways out of machine)
6. Reverse order to reassemble.

Fig. 32



Fitting axles with roller rings

1. Position axles with roller rings and bearings corresponding to that when MAXIROLL is extended, resting on the ground.
2. Extend roller and carefully lower over the axles.
3. Fit bolts (A)



Ensure no personnel are within the machine's extension radius when activating hydraulics.



Do not activate hydraulics if there are personnel within machine extension radius.

Replacing axles, bearings or roller rings

1. Slacken bearing screws (A) and withdraw bearings
2. Slacken stop ring bolts (B) and withdraw stop rings.
3. Withdraw roller rings from axle
4. Reverse order to reassemble
5. Apply Loctite to bearing screws

Fig. 33

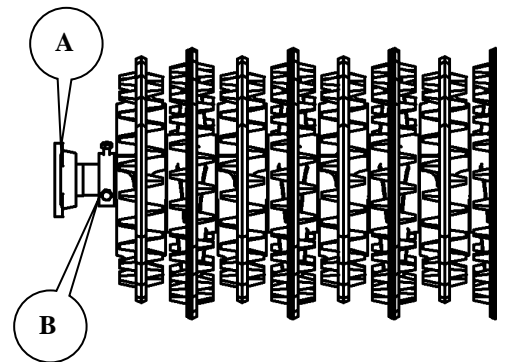

Crosskill ring

Note axle direction of rotation.

1. After the outer stop ring (
2. Fig. B) there is a smaller ring.
3. Fit bushing (A)
4. Fit large ring (B)
5. Finish off with a small ring, and then fit a stop ring.

Fig. 104

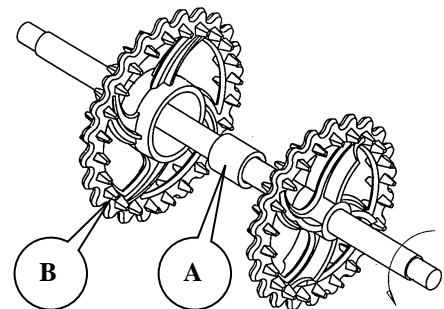



Tighten and slacken stop ring bolts a few times to ensure they bite into the axle



When fitting axles with bearings, remember to ensure the bearing lubrication nipples face backwards. This gives easy access for lubrication and protects the nipples from stones.



Check that the roller rings are close together and the direction of rotation for the Crosskill rings. Always finish with the small rings (smallest hole) at the axle ends (see "Spare part drawings")

Scrapping



Fully extend roller. It is essential that **all** cylinders are removed.



Beware of the weight of any given part when removing or disassembling. All parts **must** be supported or lifted to avoid danger of falling.

Disconnect hydraulic hoses and cylinders and drain oil. Collect oil in container to avoid pollution. Send oil and hoses for destruction.

All iron used in the machine can be recycled.

Hydraulic diagram

Fig. 35

Maxiroll 2008

Vippecyylinder
Tilting cylinder
Kippzyylinder

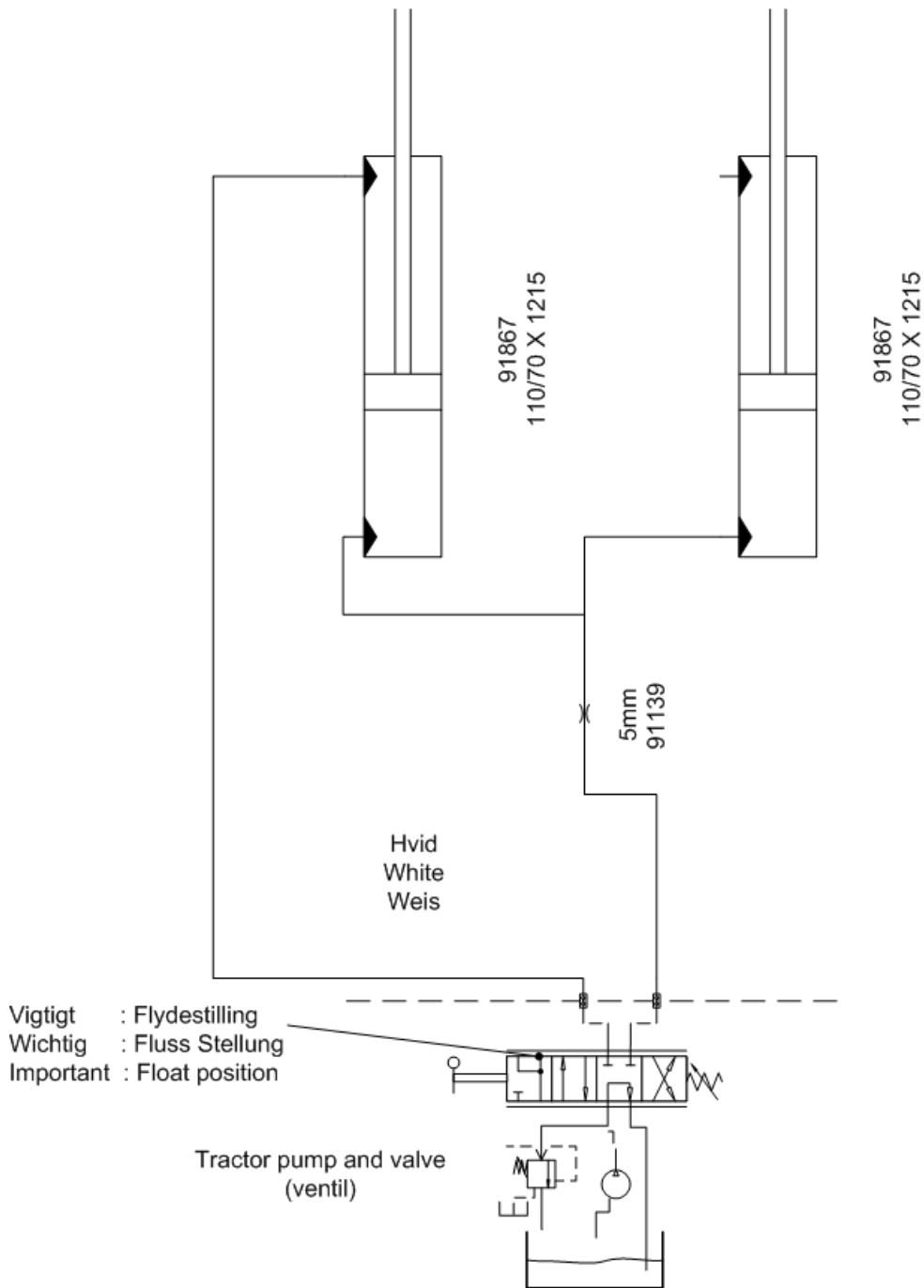

Fig. 36

Maxiroll 2008

Indklapning cylindre
 Wing fold cylinder
 Zusammen klappen zylinder

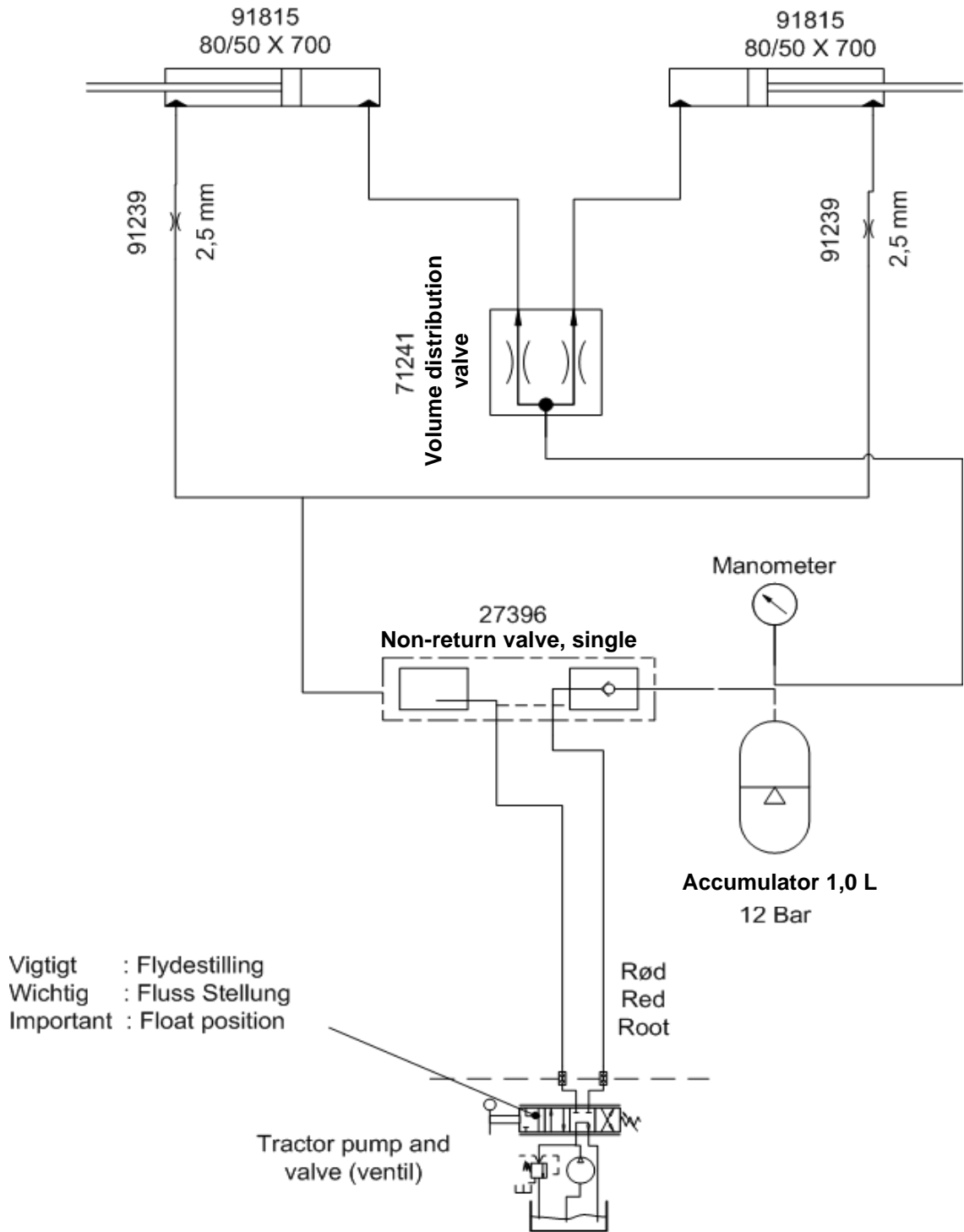

Fig. 37

Maxiroll 2008

Affjedring
Suspension
Aussetzung

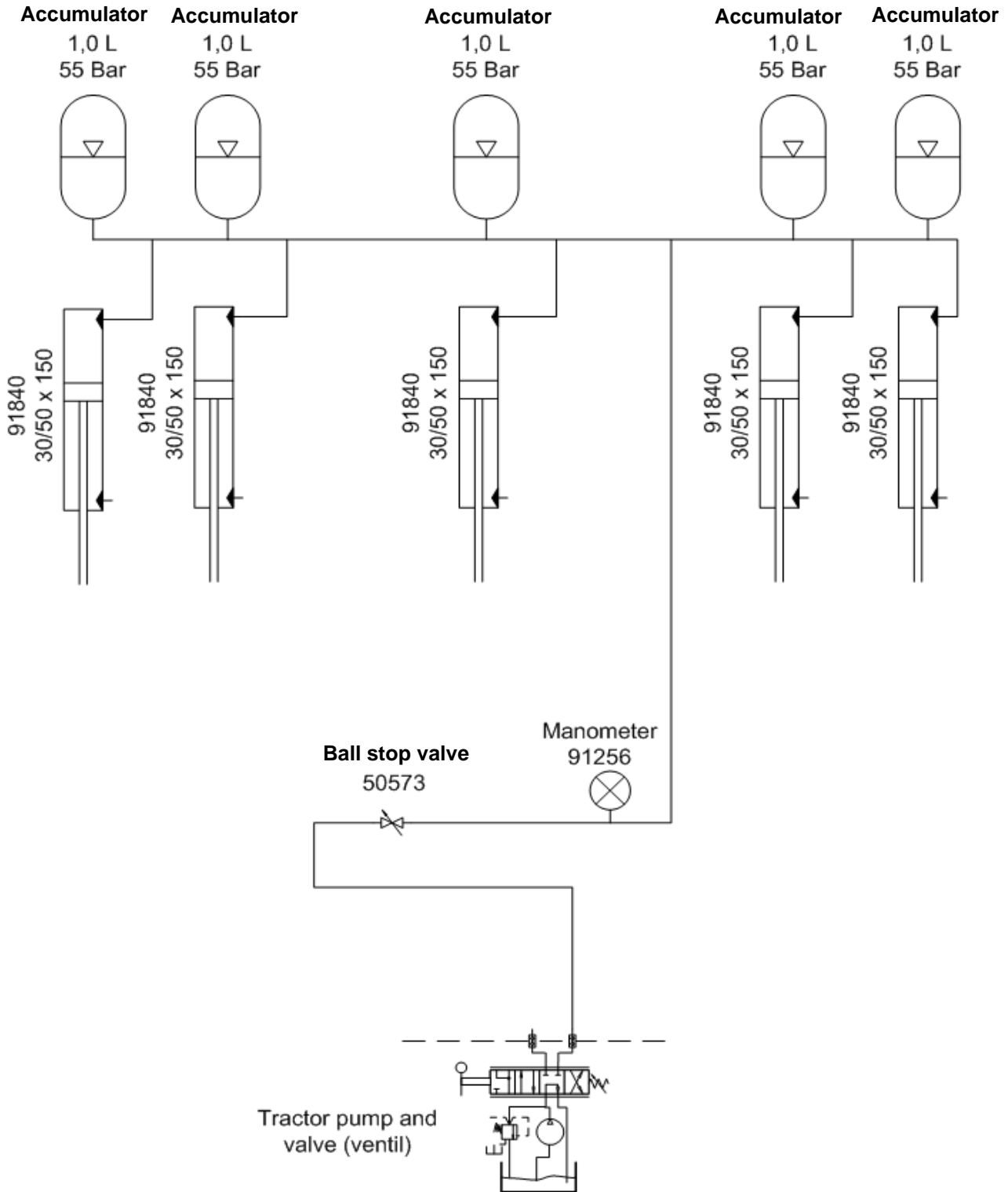
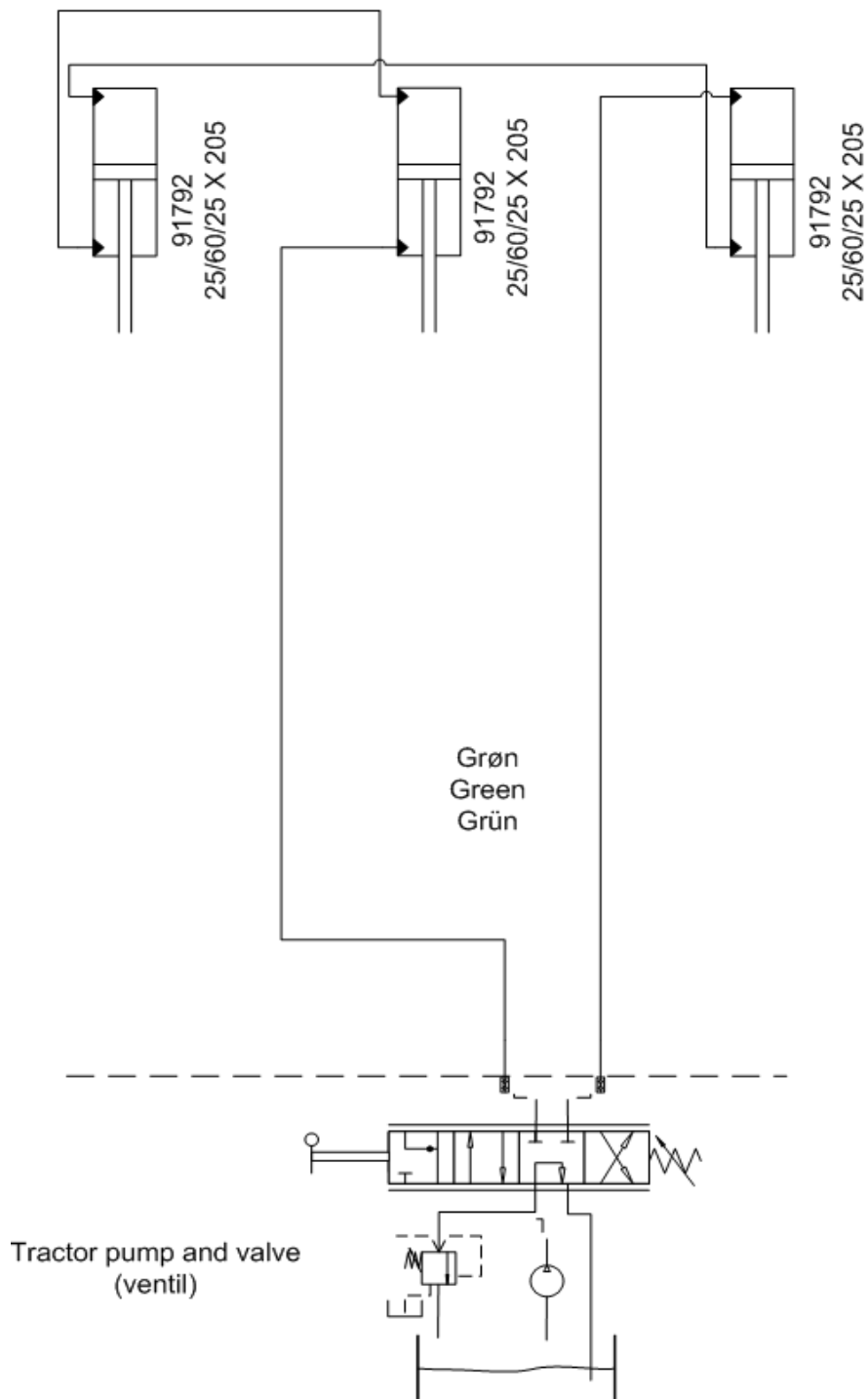

Fig. 38

Maxiroll 2008

Lamelplanke
Crackerboard



Spare parts