



# MaxiDisc



**GB**  
**400/500/600 cm**



---

# MaxiDisc

Type 400/500/600 cm

Congratulations on the purchase of your new MaxiDisc. To ensure **safe operation** and to obtain optimal use of the machine, read the rules and instructions of the following operator's manual carefully **before operating the machine**.

©Copyright 2002, DAL-BO. All rights reserved.

## Your MaxiDisc:

Type No.: \_\_\_\_\_ Serial No.: \_\_\_\_\_  
Month of manufacture: \_\_\_\_\_ Net weight (kg): \_\_\_\_\_

For prompt service, always quote your machine serial number when making enquiries regarding spare parts or service. A comprehensive index of spare parts can be found in the back of this manual to give you an overview of MaxiDisc components and to facilitate ordering.

## EU DECLARATION OF CONFORMITY

**Maskinfabriken DAL-BO A/S**  
**DK-7183 Randbøl**

Hereby declare that the above-mentioned machine has been manufactured in compliance with the provision of the Council Directive on the approximation of the laws of the Member States relating to machinery 98/37/EC, which replaces Council Directive 89/392/EEC and amendments 91/368/EEC, 93/44/EEC and 93/68/ECC concerning the Essential Health and Safety Requirements for the design and manufacture of Machinery.

**CE**

This machine complies with the safety requirements stipulated by the European safety regulations.

Maskinfabriken DAL-BO A/S

Date: \_\_\_\_\_

Carsten Jensen, CEO



# Table of Contents

<b>SAFETY .....</b>	<b>7</b>
GENERAL.....	7
HYDRAULIC SYSTEM .....	8
HITCHING .....	8
MAINTENANCE AND REPAIRS .....	8
TRANSPORT .....	9
CORRECT USE .....	9
<b>TECHNICAL DATA.....</b>	<b>10</b>
<b>HOW TO USE THIS MANUAL.....</b>	<b>11</b>
DELIVERY.....	11
<b>APPLICATION .....</b>	<b>12</b>
<b>HITCHING AND UNHITCHING.....</b>	<b>13</b>
HITCHING .....	13
HYDRAULIC SYSTEM .....	13
UNHITCHING.....	14
<b>ADJUSTMENTS AND SETTINGS.....</b>	<b>15</b>
ADJUSTABLE HITCH .....	15
SIDE WING WHEELS .....	15
ANGLE.....	16
DEPTH .....	16
HYDRAULIC WEIGHT TRANSFER .....	16
SIDE DISC .....	17
TRANSPORT LOCKS .....	17
<i>Transport locks.....</i>	<i>17</i>
<b>OPERATING AND DRIVING INSTRUCTIONS .....</b>	<b>18</b>
UNFOLDING AND FOLDING .....	18
<i>Folding .....</i>	<i>18</i>
HYDRAULIC WEIGHT TRANSFER .....	19
<i>Adjustment.....</i>	<i>19</i>
<i>Too much pressure .....</i>	<i>19</i>
<i>Too little pressure.....</i>	<i>19</i>
DRIVING INSTRUCTIONS .....	20
<i>Hydraulic depth adjustment .....</i>	<i>20</i>
ANGLE.....	20
TRAVEL SPEED .....	20
<i>Power requirements .....</i>	<i>21</i>
<b>TROUBLESHOOTING.....</b>	<b>22</b>
<b>OPTIONS .....</b>	<b>23</b>
DISC SCRAPERS .....	23

ELECTRO-HYDRAULIC OPERATION .....	23
F-IRON CAGE ROLLER .....	24
<i>Mounting</i> .....	24
<i>Adjustment</i> .....	24
<i>Maintenance</i> .....	24
<b>MAINTENANCE.....</b>	<b>25</b>
LUBRICATION .....	25
HYDRAULIC SYSTEM .....	26
DISC HUBS.....	26
<i>Disc hubs</i> .....	26
<i>Wheels</i> .....	27
ADJUSTING THE CASTLE NUT ON THE PACKER ROLLER PIVOT .....	27
<b>REPLACEMENTS AND REPAIRS .....</b>	<b>28</b>
HYDRAULIC SYSTEM .....	28
CHANGING ANGLE ADJUSTMENT CYLINDER .....	28
<i>Replacing angle adjustment seals</i> .....	29
CHANGING WING FOLD CYLINDERS .....	30
<i>Replacing fold/unfold cylinder seals</i> .....	30
CHANGING WHEEL FRAME CYLINDER.....	31
<i>Replacing wheel frame cylinder seals</i> .....	31
CHANGING PACKER ROLLER FOLD CYLINDERS .....	32
<i>Replacing packer roller cylinder seals</i> .....	33
REPLACING DISC HUB BEARING .....	34
DISMOUNTING/MOUNTING OF WHEELS .....	35
<i>Changing wheel bearings</i> .....	35
DISMOUNTING THE T-RING SHAFT .....	36
LIGHTS.....	37
<b>SCRAPPING .....</b>	<b>38</b>
<b>HYDRAULIC SYSTEM DIAGRAM .....</b>	<b>39</b>
<b>SPARE PARTS .....</b>	<b>40</b>

## Safety



The safety alert symbol is used throughout this manual to identify important safety warning messages concerning your safety, the safety of other users or the functional safety of the implement. Observe all safety instructions and make them readily accessible to all users of the equipment.

### General

- The operator must be thoroughly familiar with all safety precautions and operations of this equipment prior to using.
- The safety signs on the MaxiDisc contain important instructions concerning your safety, the safety of those around you, and the correct operation of the machinery.
- Never allow anyone to ride on the implement during operation or transport.
- Never allow bystanders within the operating radius of the MaxiDisc when the implement is in operation. Operate the MaxiDisc only while seated in the driver's seat of the tractor.
- Ensure that wing section locks are engaged when the MaxiDisc is in a folded position. Secure control levers against unintentional operation.
- Before performing any adjustments, maintenance or repairs on the machinery, always unfold the MaxiDisc and lower the implement to the ground or secure in transport position, set the tractor brakes, turn off the engine and remove the ignition key.
- Remember to secure the hitch stand and the lift arms (if applicable) with lynch pins.
- Operate the tractor and MaxiDisc only while seated in the driver's seat.
- Always drive according to conditions.
- Do not use the MaxiDisc unless all safety signs are installed. Replace defective safety signs immediately.

## Hydraulic System

- Never allow bystanders within the operating radius of the MaxiDisc when the hydraulic system is activated to prevent individuals from the danger of being crushed.
- Before performing maintenance or repairs on the hydraulic system, lower the implement to the ground, relieve pressure in the system, turn off the engine and remove the ignition key.
- Clean the hydraulic fittings thoroughly before connection. Ensure that the pressure is relieved in the hydraulic system before connecting the hydraulic hoses to the tractor's hydraulic services.
- After making repairs to the hydraulic system, thoroughly bleed air out of the system.
- Regularly check hydraulic hoses for defects such as cracks, bends, chafing or leaks. Replace defective hoses immediately.
- Avoid spilling oil on the ground. In case of spills, collect the oil and dispose of it properly.
- In case skin should come in contact with hydraulic oil or grease or in case clothing should become stained with oil, remove the stained clothes immediately and wash the affected skin areas thoroughly. Oil and grease are harmful to the skin.
- Escaping hydraulic oil under high pressure can penetrate the skin and cause severe injury. If an accident occurs, see a doctor immediately.

## Hitching

- An individual is in danger of being crushed during the hitching process. Never place yourself or anyone else between the tractor and the MaxiDisc, or between parts that must be attached or connected.

## Maintenance and Repairs

- Before servicing or making adjustments to the machine, securely block or unfold the machine, engage the tractor and machine brakes, turn off the engine and remove the ignition key.
- Tighten all nuts, bolts hydraulic fittings or any other fastened assemblies after a few hours' use. Check often to make sure that they remain thoroughly tightened. Inspect all pins, screws and bolts for wear or damage and make sure that all are securely in place to avoid any possible damage or breakdown of the machine.



- Dispose of oil, grease and filters according to applicable environmental regulations.

## **Transport**

- All safety and warning signs and devices required by law must be displayed, mounted and tested for public road use. The driver is responsible for the correct use of lights and markings in compliance with the present Traffic Act and Highway Code of the local traffic legislation.
- It is the responsibility of the driver to consult with local traffic authorities in order to ensure that the size, weight and load of the machinery may be transported on public roads.
- When towing the implement, the total weight of the tractor and the maximum allowed axle load must not be exceeded. The weight on the front axle must not be less than 20 percent of the total mass of the tractor. If it is less than 20 percent, extra weight must be added to the front of the tractor.

## **Correct Use**

- Correct use of the MaxiDisc includes adherence to the instructions of the manufacturer concerning operation, maintenance and repair, as well as the use of genuine factory replacement parts.
- Do not allow anyone to operate, maintain or repair the MaxiDisc unless they are familiar with the implement and they are thoroughly aware of the possible hazards.
- The manufacturer does not accept any liability for injury or warranty if the equipment has been altered in any way without prior authorization from the manufacturer or if the injury is a result of incorrect use of the implement. The user accepts complete responsibility in these cases.
- Never load extra weight onto the MaxiDisc.

## Technical Data

### MaxiDisc

Size (cm)	400	500	600
HP (recommended)	120-140	140-160	180-220
Gross weight kg:		4950	5540
<b>Packer Roller (suspended)</b>			
T-rings 70x70x8 mm (pc)	32	36	40
Sections (pc.)	2	2	2
Axles (pc.)	2	2	2
<b>Options</b>			
Disc scrapers			
Electro-hydraulic operation			
F-iron cage roller			

## How to Use This Manual

If the order of points described under the main subject areas of the manual seems confusing or illogical, refer to the Table of Contents where all subject headings can be found.

The main points of the operator's manual are placed into five main categories:

- Safety
- Set-up and Operation
- Options
- Maintenance
- Repairs

The following safety alert symbols are used throughout this manual to indicate:



Points that are extremely important for the function and life of the machinery.



Points that involve safety.

### Delivery

MaxiDisc is delivered fully assembled on a flatbed lorry. The implement may be partially disassembled for export.

If the MaxiDisc needs to be lifted, it is recommended that you lift with straps around the middle section, raising the machine so that it hangs in balance.

## Application

MaxiDisc represents a whole new generation of towed disc harrows providing the ultimate in compactness.

The MaxiDisc is specially designed for work in the uppermost soil layer where residue management is concentrated. The MaxiDisc effectively performs full cutting penetration of the field and uniform mixing and blending of plant residue and soil microorganisms in just one pass. The final element of the soil management system is a packer roller, ensuring moisture conservation and promoting an optimal microclimate for the organisms in the soil.

Fig. 1



MaxiDisc 600



MaxiDisc 600

The special construction of the MaxiDisc allows the two sections to move independently of each other.

The MaxiDisc is an effective stubble management tool for plough-free cultivation, and at the same time it conditions the soil for an ideal seedbed.

# Hitching and Unhitching

The linkage of the MaxiDisc is manufactured in compliance with DS/ISO 730-1 category II and III.

## Hitching

First mount the lift arms into the ball sockets (A). Elevate the lift and move the hitch stand up into the transport/working position (B).

Fig. 2



- Remember to secure the lift arms and the hitch stand with lynch pins.
- Remember to raise the hitch stand.



- Adjust the sway chains tightly until there is no slack in the lift arms.

## Hydraulic System

The MaxiDisc requires four double-acting hydraulic outlets.

Table 1. Hose markings

Cylinder	Colour	Outlet	Function
Wing fold	Red	Double-acting	Fold wing sections
Wheel frame	Yellow	Double-acting	Raise and lower MaxiDisc
Angle	Blue	Double-acting	Adjust working angle of discs
Depth	Green	Double-acting	Adjust working depth of discs



- Wing fold cylinder requires a hydraulic outlet with a floating position.
- Check the hydraulic hoses for kinks or pinches.

## Unhitching

The MaxiDisc must be completely folded up (in the transport position) or unfolded and resting securely on the ground before unhitching.

Swing the hitch stand into place and secure with a pin. Disconnect the hydraulic hoses, lower the MaxiDisc and remove the lift arms from the hitch.



**Remember to relieve the pressure in the hydraulic system before disconnecting the hoses.**



Unhitching of the MaxiDisc must always be carried out on even ground. Secure the MaxiDisc against unintentional operation.

## Adjustments and Settings

The MaxiDisc is preset in the factory, but it will always be necessary to make some fine adjustments before use. Numerous adjustment possibilities make your MaxiDisc more versatile and allow you to obtain optimum performance from the implement.

Fig. 3

A combination wrench is supplied for turnbuckle and castle nut adjustment.



### Adjustable Hitch

The towing height of the MaxiDisc drawbar hitch can be adjusted according to needs. This provides you with several possibilities to obtain proper adjustment to fit your tractor. Adjust by turning the hitch around.

Fig. 4



### Side Wing Wheels

If the working depth of the MaxiDisc is changed, the support wheels of the side wing sections must also be adjusted. Adjust the depth using the turnbuckle (A). The depth must be the same on both sides. Use the depth indicator mounted with the turnbuckle as a guide.

Fig. 5



## Angle

The discs can be hydraulically adjusted from 0 to 20 degrees. With hydraulic adjustment, all discs are adjusted at the same time.

The angle of the front row and the back row of discs can be adjusted individually with the turnbuckle (A). It is generally recommended that you set the row in the back slightly more aggressive than the row in the front to prevent the machine from pulling unevenly.

Lengthen or shorten the turnbuckle (A) according to needs.

If the soil is very dry and hard, set the front row of discs more aggressively than the row in the rear to increase power and effect.

Fig. 6

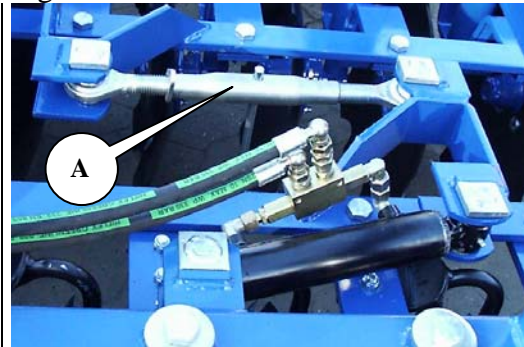

## Depth

The working depth can be adjusted using the lift and the rear T-ring packer roller. Depth adjustment is fully hydraulic.



It is important that the turnbuckles have the same length on both of the packer roller modules to ensure even depth penetration.

Measure the length of the turnbuckles. Adjust the length of the turnbuckles (A) with the supplied wrench if necessary. The length should be app. 400 mm. Maximum 420 mm.

Fig. 7



## Hydraulic Weight Transfer

(See "Operating and driving instruction, Hydraulic Weight Transfer").



## Side Disc

A disc mounted on the left edge of the MaxiDisc limits the amount of soil being cast out by the disc in the very front. Adjust the side disc vertically by using the pin (A) according to the working depth of the MaxiDisc. The disc can also be moved in a horizontal direction by loosening the mounting bolt.

Fig. 8

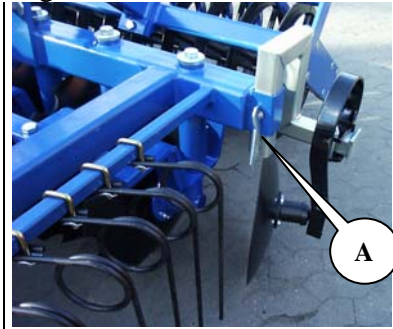

## Transport Locks

An adjustment bolt (A) on the wheel frame transport lock ensures correct placement of the transport lock.

Fig. 9



### Transport locks

To ensure the correct setting of the transport locks (hooks), a wire tightener has been mounted on the wire attached to the wings and to the packer roller. The wire must be long enough that the transport locks can be disengaged, allowing the side wings and the packer roller to be free, but also long enough that the transport locks can fall down, catch and become completely engaged on the side sections and the packer roller.

Fig. 10



Transport lock on the packer roller



Transport lock on the main frame

## Operating and Driving Instructions

Proper operation is essential for optimum performance of your MaxiDisc. Proper operation concerns both the carrying out of tillage operations in the field as well as the following of safety precautions. Make sure that you have a thorough understanding of all safety precautions.



- Every day before operating the MaxiDisc, inspect all pins, nuts, bolts and connections to be sure that all are tightened and securely in place.
- **The MaxiDisc must be in the fully raised position on both liftarms and wheel frame when moving in reverse or turning around.**

### Unfolding and Folding



Always fold and unfold the wings of the MaxiDisc while the equipment is stationary and the tractor is parked.

The mechanical transport locks become engaged and disengaged when the side wings are folded and unfolded between the transport and the working position. Upon arrival to the working area, activate the lever for the folding/unfolding of the side wings. Make sure that the side sections are fully raised. Release the transport lock by activating the lever to the wheel cylinder so that the cylinder is pressed out to the fully extended position. The transport locks will be released, and the side wings together with the packer roller can then be unfolded.

#### Folding

Move the wheel cylinders to the fully extended position before folding up the side sections into the transport position. This ensures that the mechanical transport lock of the wheel frame is able to fall down and lock the wheel frame into place.

After the side wings and the packer roller have been folded up, lower the MaxiDisc so that the transport lock of the wheel suspension locks firmly and securely.



Make sure that all transport locks are securely fastened before transporting the implement on public roads.

## Hydraulic Weight Transfer

The hydraulic weight transfer system of the MaxiDisc ensures an even distribution of weight across all sections of the roller and an even field finish on all types of terrain. The MaxiDisc is divided into two sections (3m or 2.5m) which can move independently of each other.



It is very important to adjust the hydraulic weight transfer system correctly and set the lever in the **floating position**.

### Adjustment

1. Unfold the MaxiDisc and continue to hold the wing fold/unfold cylinder lever in the same position until the pressure reading of the fold/unfold cylinder (red outlet) displayed on the manometer is approx. 50 bar.

Fig. 11

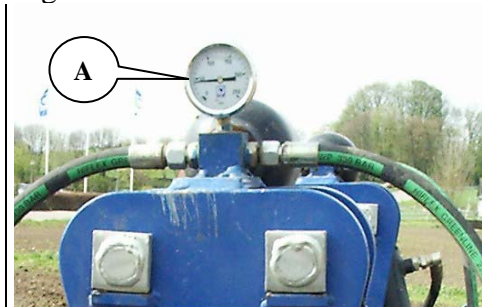

2. Set the cylinders in the floating position. The floating position is necessary to achieve hydraulic weight transfer, in which the sections are free to move individually.
3. It may be necessary to readjust the pressure of the hydraulic weight transfer. It might also be necessary to operate the machinery at a higher or lower pressure, depending on soil conditions.

### Too much pressure

1. The pressure on the outermost rings of the wing sections will be too great. The rings and the support wheels will be pressed too far down and they will leave clearly visible ridges in the soil.
2. The middle/inside section of the side wings will not penetrate deep enough into the soil and the field finishing will be uneven.

### Too little pressure

1. There is not enough pressure on the outer rings of the wing sections and the support wheels to press the T-rings sufficiently into the soil.
2. The middle of the MaxiDisc will pack the soil too heavily, resulting in an uneven field finishing.

## Driving Instructions

The MaxiDisc is an effective soil management tool that is capable of mixing a large quantity of soil and plant residue. Proper driving practices and equipment settings are necessary to ensure that the fields will be left even and without any ridges.

Best results will be achieved by driving slightly diagonally to the sowing direction. When the correct working depth has been found, set a fixed depth stop position on the tractor lift. The depth can also be continually adjusted during operation if necessary.



The MaxiDisc must be adjusted to operate in a perfectly level and horizontal position, both parallel and perpendicular to the direction of travel, to obtain level and uniform field finishing.

### Hydraulic depth adjustment

The penetration depth can be freely adjusted during operation. Adjust the depth by using the indicator (A) as a guide.

Fig. 12

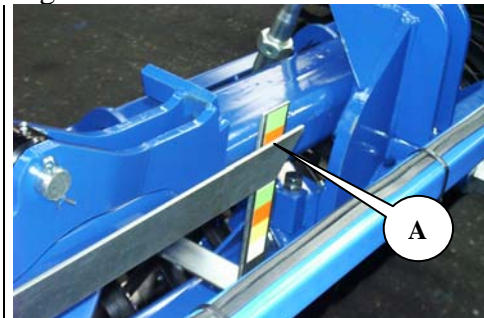

If the packer roller sections are not working at the same depth, it is necessary to reset the cylinders by moving them to the fully extended position and then returning to the original starting depth.

## Angle

The angle of the discs can be continuously adjusted hydraulically during operation, enabling the operator to obtain the optimal setting according to field conditions. If there are many patches of plant residue on the field, the angle can quickly be reduced to avoid blockage. The angle can also be reduced if the need for pulling force becomes too great.

## Travel Speed

A working speed between 8-15 km/hour is recommended, but always drive according to conditions.

When travel speed is increased, wear on the implement is increased, especially under dry soil conditions. Damage to the discs and T-rings may also result from driving too fast under unfavourable conditions.

**Power requirements**

Power requirements change according to soil type, terrain and travel speed.

**Table 2, Guidelines for power requirements in HP**

Working width	500 cm	600 cm
Power requirements (hp)	140-160	180-220

## Troubleshooting

Table 3

Problem	Cause	Action
Soil is thrown too far out to the sides, creating a ridge.	<ul style="list-style-type: none"> <li>• MaxiDisc is not horizontal.</li> </ul>	<ul style="list-style-type: none"> <li>• Raise the lift until the main frame is horizontal.</li> </ul>
	<ul style="list-style-type: none"> <li>• The travel speed is too fast.</li> </ul>	<ul style="list-style-type: none"> <li>• Drive slower.</li> </ul>
	<ul style="list-style-type: none"> <li>• The angle is too aggressive.</li> </ul>	<ul style="list-style-type: none"> <li>• Adjust the angle.</li> </ul>
	<ul style="list-style-type: none"> <li>• Driving too closely or too far away from the previous pass.</li> </ul>	<ul style="list-style-type: none"> <li>• Drive more precisely and closer to the previous pass.</li> </ul>
A depression or furrow in the soil develops between passes.	<ul style="list-style-type: none"> <li>• Driving too closely or too far away from the previous pass.</li> </ul>	<ul style="list-style-type: none"> <li>• Drive more precisely and closer to the previous pass.</li> </ul>
	<ul style="list-style-type: none"> <li>• The rear row of discs is not adjusted correctly.</li> </ul>	<ul style="list-style-type: none"> <li>• Set the rear row of discs more or less aggressively.</li> </ul>
Outer disc penetrates deeper on one side than the other.	<ul style="list-style-type: none"> <li>• Packer roller turnbuckles are not equal in length.</li> </ul>	<ul style="list-style-type: none"> <li>• Adjust the turnbuckles on the packer roller until they have the same length.</li> <li>• For hydraulic depth adjustment, reset the cylinders.</li> </ul>
	<ul style="list-style-type: none"> <li>• The side wheels are set at different heights.</li> </ul>	<ul style="list-style-type: none"> <li>• Adjust the side wheels to the same height.</li> </ul>

## Options

Your MaxiDisc can be equipped with various types of optional equipment, depending on individual needs.

### Disc Scrapers

Disc scrapers can be mounted if necessary. The scrapers are fastened by two bolts and ensure clean discs under all field conditions.

Fig. 13

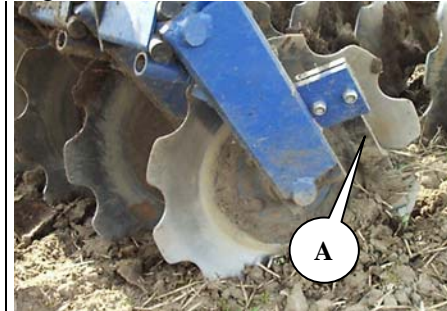

Adjust the disc scrapers to allow only 3 to 5 mm of space between each disc and scraper.

### Electro-Hydraulic Operation

Electro-hydraulic operation requires only two double-acting outlets on the tractor. **One outlet is to be used solely for hydraulic weight transfer**, which also functions for folding/unfolding of the side wings. MaxiDisc's functions are accessed through four electronic sockets that are mounted in a box located on the tractor.

Electro-hydraulic operation is particularly an advantage when there is a lack of hydraulic outlets on the tractor. Hitching of the implement also becomes much easier since there are only four hydraulic hoses to be connected to the tractor.

To activate a function, turn on the switch related to the function and move the hydraulic lever. After completing the operation, turn off the switch and another function can be activated. A function that is frequently used for field work can be left on, and in this case, the hydraulic lever can simply be moved when needed.

A green light is lit when a switch is activated. When shifting to another function, the previous switch must be turned off first since only one switch may be on at a time. There is a green indicator light associated with each switch that lights when that particular function is activated.

## F-Iron Cage Roller

An F-iron cage roller can be mounted behind the packer roller to achieve additional field finishing. The F-iron cage roller is constructed as a roller yet has a smaller diameter than the packer roller. This reduced diameter provides a faster rotation, thereby crushing clods more effectively. At the same time, it further packs the surface soil for improved moisture conservation.

### Mounting

Unfold the MaxiDisc and lower it onto the ground.

1. Attach the U-bolt (A) to the toolbar frame.
2. Mount the middle section (B).
3. Mount the F-iron cage roller and the stone releasers (C) (see "Spare Parts").

Fig. 14

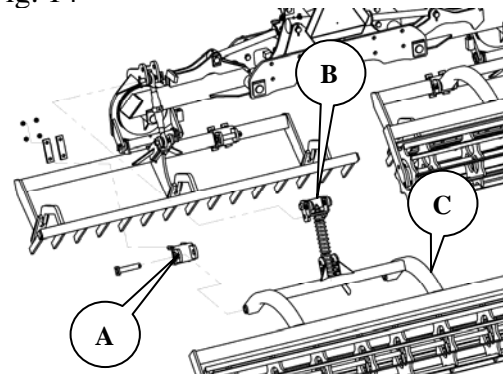

Tighten all nuts and bolts after few hours' use. Inspect all pins and bolts for wear or damage and make sure that all are securely in place to avoid any possible damage or breakdown of the machine.

### Adjustment

Down pressure of the F-iron cage roller must be adjusted according to depth and field conditions.

Move the pin (A) to adjust the pressure of the F-iron cage roller.

The pressure of the cage roller must not be greater than necessary. Increased wear and load on the machine will result.

Fig. 15

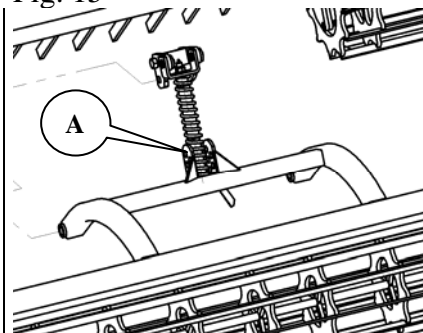

### Maintenance

Lubricate the bearings after every 25 hours of operation. Lubricate the stone releasers daily.



# Maintenance

Proper maintenance ensures a long life for the MaxiDisc and also optimum performance from the implement. To facilitate maintenance, grease fittings have been mounted on those locations where wear on the equipment is the greatest.

## Lubrication

Fig. 16



Table 5

Lubrication points	Number of fittings	Lubrication interval (hours)	Photo
Wheel suspension hinge	2	25	A
Wheel cylinder (top/bottom)	2	25	A
Packer roller cylinder, folding (top/bottom)	4	50	B
Packer roller pivot	2	Daily	
Center pin for unfolding of packer roller	2	50	
Depth control, packer roller centre pin	2	50	
Packer roller bearings, T-rings	4	50	C
Hinge for wing fold/unfold	4	50	
Cylinder eye for wing folding/unfolding	4	50	D
Hitch, vertically and horizontally	2	25	E
Wheel bearings (see "Adjustments, wheel bearings")		1 year	
Hub	39/47	50	F
Disc pipe	39/47	50	G

Side disc	2	50	H
Angle adjustment cylinder	2	25	I



Tighten all nuts, bolts, hydraulic fittings or any other fastened assemblies after the first workday. Inspect all pins and bolts for wear or damage and make sure that all are securely in place to avoid any possible damage or breakdown of the machine.



Before servicing the machine, always lower the implement, engage the tractor brakes, stop the engine and remove the ignition key to avoid unintentional operation and personal injury.



Lubricate all lubrication points at least once a year.

### Hydraulic System



Inspect all hydraulic hoses for chafing or leaks. Check hoses for pinching.



To avoid rust, any projecting or exposed piston rods should be coated with oil or grease if the MaxiDisc is to be parked for a long period of time. Remember to remove the oil or grease prior to operation.

### Disc Hubs

#### Disc hubs

Tighten the disc hubs once a year or as needed.

1. Screw off the cap (A).
2. Remove the split cotter pin from the nut.
3. Tighten the nut  $\frac{1}{4}$  turn or until there is no play in the hub.

Fig. 17

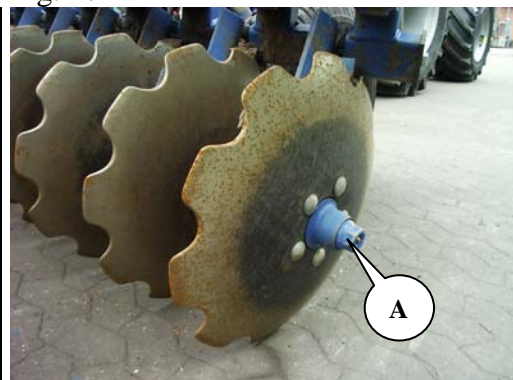

## Wheels

Lubricate and adjust the wheel bearings once a year. Make sure that the tyre pressure is correct (see tyre information).

### Adjustment and lubrication of wheel bearings

1. Remove the hubcap.
2. Take out the split pin.
3. Tighten the castle nut  $\frac{1}{6}$  of a rotation until the hole is lined up with the axle. The wheel must be able to rotate freely. There should be a little slack in the hub when the wheel is moved from side to side. If there is a lot of slack in the hub, repeat the process.
4. Replace the pin.
5. Fill the hubcap  $\frac{3}{4}$  full with lubricant and reinstall.

## Adjusting the Castle Nut on the Packer Roller Pivot

There must not be any slack in the packer roller pivot. The castle nut must be tightened if there is any slack between the plates.

Fig. 18



1. Knock the slotted split pin (A) out of the axle.
2. Tighten the castle nut to a torque of 50 Nm, or until there is no longer a gap between the plates when the MaxiDisc is resting on the packer roller. Loosen the castle nut until the hole in the axle lines up with the notches of the castle nut. Remember to insert the slotted split pin.

The suspended packer roller sections must never be tightened more than they are able to freely fall back into a horizontal position after they have been moved vertically.

## Replacements and Repairs



Safety is important in connection with **all** repair work on the MaxiDisc. The following safety precautions and the precautions listed in the beginning of this manual must be observed.



Before performing any adjustments, maintenance or repairs on the machinery, always unfold the MaxiDisc and lower the implement to the ground or secure in transport position, set the tractor brakes, turn off the engine and remove the ignition key to avoid unintentional operation.



Pay careful attention to safety when performing repair work on the hydraulic system. Remove hydraulic pressure prior to doing any maintenance, and block the part if needed.



After making repairs to the hydraulic system, always bleed air out of the system before operating the MaxiDisc again to avoid any possible personal injury or mechanical breakdown or damage. Never allow bystanders within the operating radius of the MaxiDisc when the hydraulic system is activated.

### Hydraulic System

#### Changing angle adjustment cylinder

Lower the MaxiDisc to the ground and relieve the pressure in the hydraulic system.

- 1 Disconnect the hoses.
- 2 Remove the pins.
- 3 The cylinder is now free. Install a new cylinder. Follow the instructions in reverse order.

Fig. 19



After installing the new cylinder, always bleed air out of the system and check for leaks.

## Replacing angle adjustment seals

Fig. 20

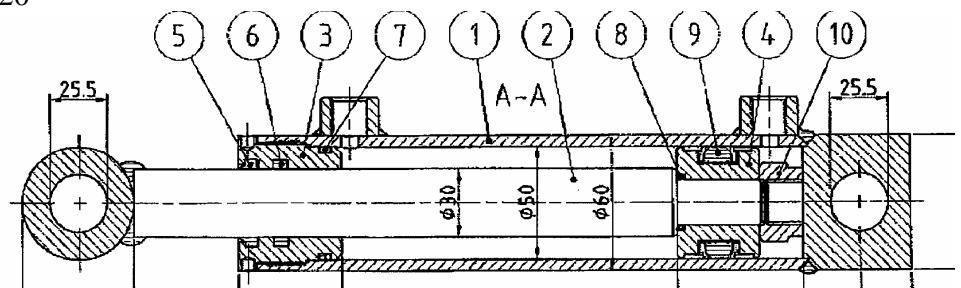

### Cylinder 50/30-150

- 1 Empty the oil from the cylinder by carefully moving the cylinder back and forth.
- 2 Move the piston to the middle position. Unscrew the gland (pos. 3) from the cylinder casing (pos. 1). (A special tool is needed to remove the gland). If the gland is stuck, it may help to warm up the very front of the socket. When the gland has been unscrewed, pull the piston towards the gland. Pull the piston rod completely out of the cylinder casing (pos. 1).
- 3 Remove the self-locking nut (pos. 10) holding the sleeve (pos. 4).
- 4 Pull the sleeve (pos. 4) off the piston rod (pos. 2).
- 5 Pull the gland (pos. 3) off the piston rod (pos. 2).
- 6 Remove the seals from the gland and the sleeve (pos. 5+6+7+8+9).
- 7 Clean all parts thoroughly. Check for filings, shavings, burrs, and make sure that there is no rust around the scraper ring (pos. 5) in the gland. If rust is found, it must be removed.

### Assembly

- 1 Assemble the new seals (pos. 5+6+7+8+9) into the gland and the sleeve.
- 2 Lubricate the screw threads on the gland (pos. 3) and the cylinder casing (pos. 1) with oil.
- 3 Mount the gland (pos. 3) onto the piston rod.
- 4 Mount the sleeve (pos. 4) and screw on the self-locking nut **with Loctite**. Make sure that the screw threads are completely clean and free from oil or other impurities before using Loctite. **Do not refill the oil for the first 12 hours after the application of Loctite.**
- 5 Lubricate the outermost seal of the sleeve that has contact with the cylinder casing and the inside of the cylinder casing, then guide the piston rod into the middle position of the casing.
- 6 Screw the gland onto the casing and tighten.

## Changing Wing Fold Cylinders

When performing repairs, make sure the MaxiDisc is unfolded and resting on the ground. Relieve the pressure in the hydraulic system. Disconnect the hoses and remove the cylinders.

Fig. 21



After installing a new cylinder, always bleed air out of the system and check for leaks. Never allow bystanders within the operating radius of the implement.

### Replacing fold/unfold cylinder seals

Fig. 22

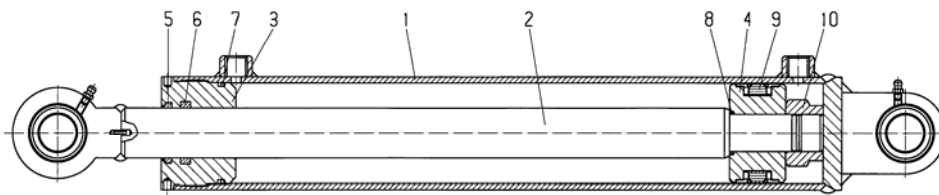

#### Cylinder 80/40X400

- 1 Empty the oil from the cylinder by carefully moving the cylinder back and forth.
- 2 Move the piston to the middle position. Unscrew the gland (pos. 3) from the cylinder casing (pos. 1). (A special tool is needed to remove the gland). If the gland is stuck, it may help to warm up the very front of the socket. When the gland has been unscrewed, pull the piston towards the gland. Pull the piston rod completely out of the cylinder casing (pos. 1).
- 3 Remove the self-locking nut (pos. 10) holding the sleeve (pos. 4).
- 4 Pull the sleeve (pos. 4) off the piston rod (pos. 2).
- 5 Pull the gland (pos. 3) off the piston rod (pos. 2).
- 6 Remove the seals from the gland and the sleeve (pos. 5+6+7+8+9).
- 7 Clean all parts thoroughly. Check for filings, shavings, burrs, and make sure that there is no rust around the scraper ring (pos. 5) in the gland. If rust is found, it must be removed.

### Assembly

- 8 Assemble the new seals (pos. 5+6+7+8+9) into the gland and the sleeve.
- 9 Lubricate the screw threads on the gland (pos. 3) and the cylinder casing (pos. 1) with oil.
- 10 Mount the gland (pos. 3) onto the piston rod.
- 11 Mount the sleeve (pos. 4) and screw on the self-locking nut **with Loctite**. Make sure that the screw threads are completely clean and free from oil or other impurities before using Loctite. **Do not refill the oil for the first 12 hours after the application of Loctite.**
- 12 Lubricate the outermost seal of the sleeve that has contact with the cylinder casing and the inside of the cylinder casing, then guide the piston rod into the middle position of the casing.
- 13 Screw the gland onto the casing and tighten.

### Changing Wheel Frame Cylinder

The MaxiDisc must first be unfolded and lowered so that the discs are resting securely on the ground. Relieve the pressure in the wheel cylinder so that the wheels are resting on the ground.

1. Dismount the hoses. (To avoid ground pollution, collect the oil in a tray placed underneath the working area while carrying out repairs on the implement.)
2. Remove the split cotter pin and the pin. The cylinder is now free.
3. Mount the cylinder in reverse order. Remember to make sure that the pin is engaged in the stop and that the pins are secured with split cotter pins.



After mounting the cylinder, carefully raise and lower the MaxiDisc several times to bleed air out of the system. Initially, the MaxiDisc must not be lifted higher than 10-20 cm from the ground. Never allow bystanders within the operating radius of the MaxiDisc.

### Replacing wheel frame cylinder seals

Fig. 23

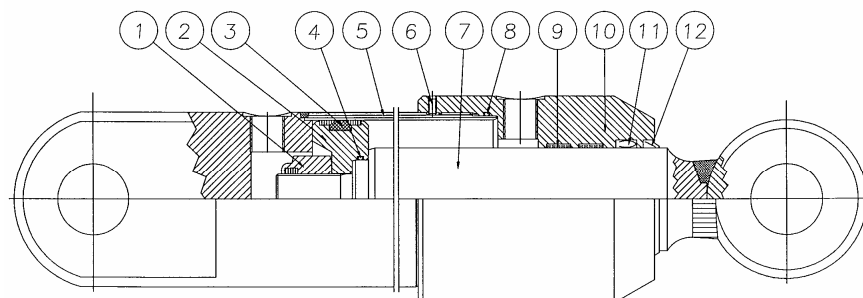

#### Cylinder 80/50-350

1. Empty the oil from the cylinder by moving the cylinder back and forth.

2. Move the piston to the middle position. Unscrew the gland (pos. 10) from the cylinder casing (pos. 5). A special tool is needed to remove the gland. If the gland is stuck, it may help to warm up the very front of the socket. When the gland has been unscrewed, pull the piston out towards the gland. Pull the piston rod (pos. 7) out of the cylinder casing (pos. 5).
3. Remove the locking nut (pos. 1) which holds the sleeve (pos. 2).
4. Pull the sleeve (pos. 2) off the piston rod (pos. 7).
5. Pull the gland (pos. 10) off the piston rod (pos. 7).
6. Remove the seals from the gland and the sleeve (pos. 3+4+6+8+9+11+12).
7. Clean all parts thoroughly. Check for filings, shavings, burrs and make sure that there is no rust around the scraper ring (pos. 12) in the gland. If this is the case, it must be removed.

#### Assembly

1. Assemble the new seals into the gland and the sleeve (pos. 3+4+6+8+9+11+12).
2. Lubricate the screw threads on the gland (pos. 10) and the cylinder casing (pos. 5).
3. Place the gland (pos. 10) onto the piston rod (pos. 7).
4. Mount the sleeve (pos. 2) and screw on the self-locking nut **with Loctite**. Make sure that the screw threads are completely clean and free from oil or other impurities before using Loctite. **Do not refill the oil for the first 12 hours after the application of Loctite.**
5. Lubricate the outermost seal on the sleeve which has contact with the cylinder casing and the inside of the cylinder casing with oil, then guide the piston into the middle position.
6. Fit the gland onto the cylinder casing and tighten.
7. Mount the cylinder.
8. Attach the hoses. Make sure that the hoses are not caught or squeezed in any way and that the connections are airtight.

## Changing Packer Roller Fold Cylinders

The MaxiDisc must first be unfolded and lowered so that the discs are resting securely on the ground. Relieve the pressure in the wheel cylinder so that the wheels are resting on the ground.

4. Dismount the hoses. (To avoid ground pollution, collect the oil in a tray placed underneath the working area while carrying out repairs on the implement.)
5. Remove the split cotter pin and the pin. The cylinder is now free.
  1. Mount the cylinder in reverse order. Remember to make sure that the pin is engaged in the stop and that the pins are secured with split cotter pins.



After installing the new cylinder, always bleed air out of the system and check for leaks. Never allow bystanders within the operating radius of the MaxiDisc.



## Replacing packer roller cylinder seals

Fig.24

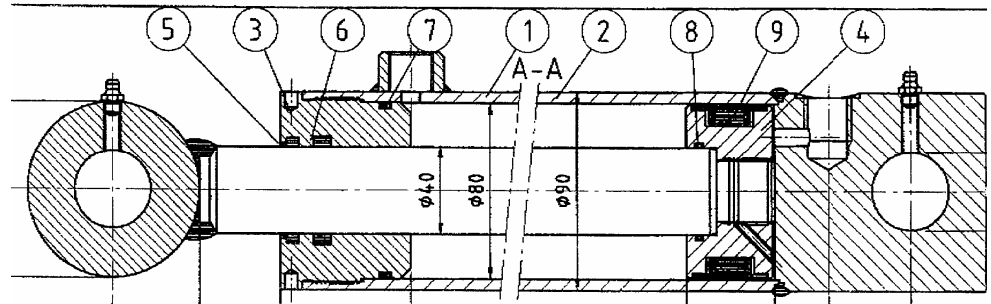

### Cylinder 80/40-350

1. Empty the oil from the cylinder by moving the cylinder back and forth.
2. Move the piston into the middle position. Unscrew the gland (pos. 3) from the cylinder casing (pos. 1). A special tool is needed to remove the gland. If the gland is stuck, it may help to warm up the very front of the socket. When the gland has been unscrewed, pull the piston out towards the gland. Pull the piston rod out of the cylinder casing (pos. 1).
3. Remove the locking nut which holds the sleeve (pos. 4).
4. Pull the sleeve (pos. 4) off the piston rod (pos. 2).
5. Pull the gland (pos. 3) off the piston rod (pos. 2).
6. Remove the seals from the gland and the sleeve (pos. 5+6+7+8+9).
7. Clean all parts thoroughly. Check for filings, shavings, burrs and make sure that there is no rust around the scraper ring (pos. 5) in the gland. If this is the case, it must be removed.

### Assembly

1. Assemble the new seals into the gland and the sleeve (pos. 5+6+7+8+9).
2. Lubricate the screw threads on the gland (pos. 3) and the cylinder casing (pos. 1).
3. Place the gland (pos. 3) onto the piston rod.
4. Mount the sleeve (pos. 4) and screw on the self-locking nut **with Loctite**. Make sure that the screw threads are completely clean and free from oil or other impurities before using Loctite. **Do not refill the oil for the first 12 hours after the application of Loctite.**
5. Lubricate the outermost seal on the sleeve which has contact with the cylinder casing and the inside of the cylinder casing with oil, then guide the piston into the middle position.
6. Fit the gland onto the cylinder casing and tighten.
7. Mount the cylinder.
8. Attach the hoses. Make sure that the hoses are not caught or squeezed in any way and that the connections are airtight.

## Replacing Disc Hub Bearing



The MaxiDisc must be unfolded with the side wings and main frame securely blocked and supported before pulling the disc leg out of the gang tube.

- 1 Remove the bolts (A) and (B).
- 2 Pull the disc leg out of the gang tube.

Fig. 25

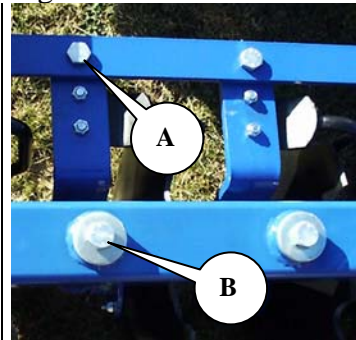

- 1 Remove the disc.
- 2 Unscrew the cap (21).
- 3 Take out the split cotter pin (20) holding the castle nut.
- 4 Remove the castle nut (19).
- 5 Pull off the hub (22) with a wheel puller.
- 6 Slide off the inner bearing.
- 7 Pull off the inner ring.

Fig. 26

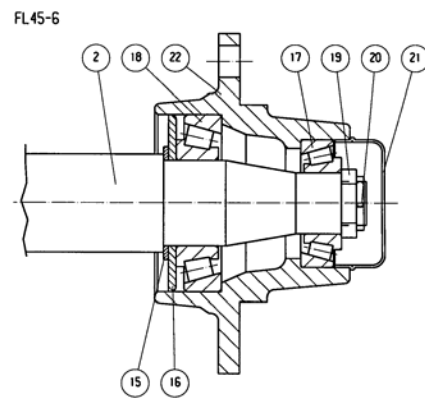

Clean the shaft and the cap.

- 1 To assemble, follow the instructions above in reverse order. Screw the castle nut onto the shaft while simultaneously turning the hub. Tighten the nut until it is difficult to turn the wheel. Now loosen the castle nut until the split pin lines up with a hole in both the shaft and the castle nut (if the wheel still drags when it is turned, loosen the castle nut to the next hole in the nut).
- 2 Remember to replace the split cotter pin.
- 3 Fill the cap  $\frac{3}{4}$  with grease and reinstall.

## Dismounting/Mounting of Wheels

To dismount the wheels, lower the MaxiDisc until the discs are resting on the ground and the wheels are clear off the ground. Remove the lug nuts. The wheel can then be removed. After mounting a new wheel, screw on the lug nuts and tighten with a “hard hand”. Next, lower the wheels until they are touching the ground and tighten the nuts to a torque of 300 Nm.



It is important that the wheel lug nuts and the mounting surface of the rim are clean; otherwise the nuts will become loose.

### Changing wheel bearings

1. Remove the hubcap (pos. 21).
2. Take out the split cotter pin (pos. 20).
3. Unscrew the castle nut (pos. 19).
4. Knock the hub off the axle (pos. 2).
5. Remove the bearings (pos. 17+18).
6. Remove the seal (pos. 19).

Fig. 27

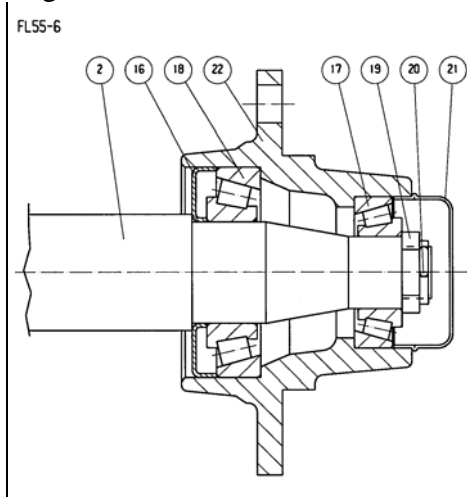

### Assembly

1. Mount the outer rings of the bearings (pos. 17+18) into the hub (pos. 22).
2. Position the seal (pos. 16).
3. Place the inner ring of the bearing (pos. 18) onto the axle (pos. 2) and mount the axle into the hub.
4. Place the inner ring of the bearing (pos. 17) onto the axle (pos. 2).
5. Screw the castle nut onto the axle (pos. 2) and turn the hub (pos. 22) at the same time. Tighten the castle nut until there is drag on the hub as it is turning. Next, loosen the castle nut a quarter turn or until the hub turns around easily.
6. Replace the split cotter pin (pos. 20).
7. Fill the hubcap (pos. 21) half full with ball bearing grease and reinstall.

## Dismounting the T-Ring Shaft

Unfold the packer roller into the working position and lower the transport wheels until they just barely carry the weight of the MaxiDisc, but the T-rings should still be resting on the ground. The main frame is supported in this position.



Be aware that the scrapers and the shaft are both held by the same bolt.

- 1 Dismount the bearings, shaft and T-rings from the frame. The shaft is now free and can be rolled backwards.
- 2 Loosen the set screws in the bearings.
- 3 Remove the bolts at the end of the shaft.
- 4 Dismount the T-rings.

Fig. 28

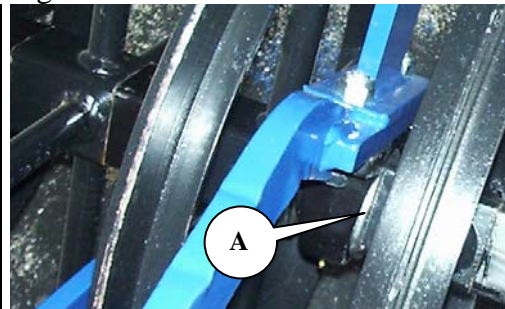

## Mounting

1. Mount T-rings onto the 70x70x4 mm square tube.
2. Place the bearings and the assembled T-ring sections onto the shaft. Be sure to place washers (A) between the bearings and the T-ring sections. **It is important that the distance between the bearings is the same as the distance on the frame.**
3. Fasten the T-rings together with the end plates, and if necessary place washers in between. Secure the set screws with Loctite.

In some cases, the rings may be difficult to slide off the shaft. Using a high-pressure cleaner to rinse in between the rings and the shaft helps to remove rust and soil which is stuck onto the shaft.



When mounting the axle with bearings, make sure to position the bearings with the grease fittings facing towards the back, enabling easier access for lubrication and protecting them from stones.

## Lights

Position of electric cables in 7-pole receptacle:

Table 6

Colour	Male plug	Function
White	31	Frame
Red	54	Stop signal
Yellow	1L	Turn signal, left
Green	1R	Turn signal, right
Black	58L	Rear light, left
Brown	58R	Rear light, right
Blue	54G	-

## Scrapping



The MaxiDisc must be unfolded. It is important to remove the pressure in **all** cylinders.



When dismantling/mounting components, always pay attention to the weight of the part that you are about to handle. It is **important** to support or secure the part so that it cannot fall.

Dismount all hydraulic hoses and cylinders and empty the oil. To avoid pollution of the ground and the surrounding area, collect as much oil as possible. Dispose of the oil and the hoses properly.

All iron used in the machine is recyclable.

# Hydraulic System Diagram



## MAXIDISC 500+600

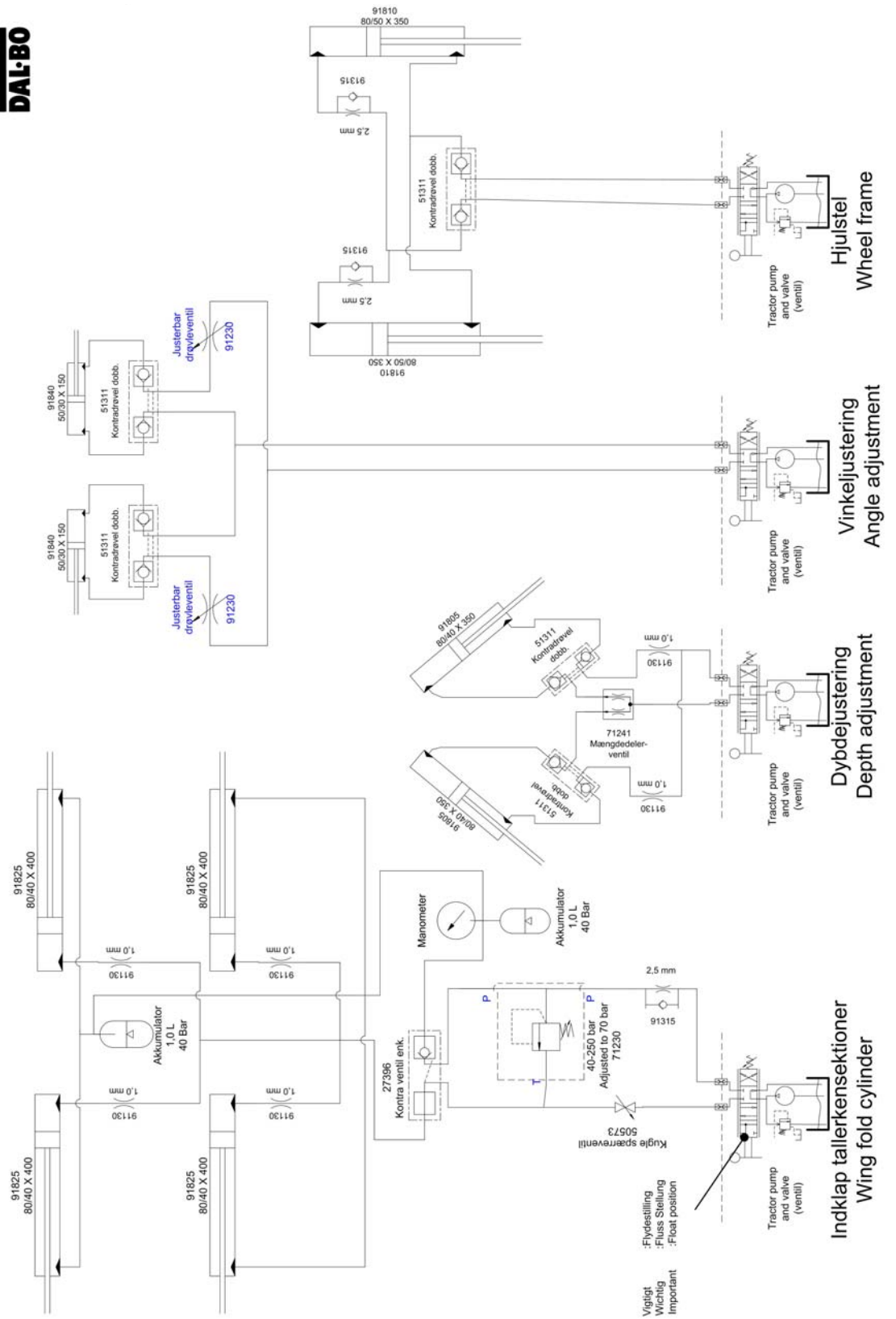

# Spare Parts