

DALBO®

**Reservedele
Spareparts
Ersatzteile
Pieces**

**POWERROLL
1830
Serie no. 106916-108083**

MADE IN  DENMARK

Indholdsfortegnelse,

Table of Contents, Inhaltsverzeichnis, Table des matières

RESERVEDELSLISTENS OPBYGNING, THE CONSTRUCTION OF THE SPAREPARTSLIST	5
POWERROLL1830 U. G/A	6
GODS PÅ AKSEL 1830 CAMBRIDGE SNOWFLAKE 55, METAL ON SHAFT, GIESSGUT AUF WELLEN, METAL SUR ARBRES	9
GODS PÅ AKSEL 1830 CROSSKILL 60, METAL ON SHAFT, GIESSGUT AUF WELLEN, METAL SUR ARBRES	11
GODS PÅ AKSEL 1830 CROSS COMBI 50, METAL ON SHAFT, GIESSGUT AUF WELLEN, METAL SUR ARBRES	13
LEJE KPL. BEARING CPL. LAGER KPL. PALIER CPL.	15
LEJEFÆSTE MED DÆMPNING. BEARING PLATE. LAGERBEFESTIGUNG. FIXATION DE PALIER.....	17
TRÆK KAT. 3, ZUG, DRAWBAR, ATTELAGE	19
SPORMARKERING, SPURANREISSER, MARKER ARM, MARQUEUSE	21
LYGTESÆT, LEUCHTSSATZ, LIGHT SET, ENSEMBLE DE PHARES	23
HYDRAULIK – VIPPECYLINDER, HYDRAULIK, HYDRAULIC, HYDRAULIQUE	25
HYDRAULIK – INDERSTE KLAPCYLINDER, HYDRAULIK, HYDRAULIC, HYDRAULIQUE.....	27
HYDRAULIK – YDERSTE KLAPCYLINDER, HYDRAULIK, HYDRAULIC, HYDRAULIQUE	30
HYDRAULIK FOR SPORMARKERING, HYDRAULIK, HYDRAULIC, HYDRAULIQUE	32
HYDRAULIK FOR STØTTEBEN, HYDRAULIK, HYDRAULIC, HYDRAULIQUE.....	34
HYDRAULIK TIL BREMSER, HYDRAULIK, HYDRAULIC, HYDRAULIQUE	36
STENKASSE 100 L MED BESLAG, STEINKISTE, STONE BOX, BOITE A PIERRES	38
TRYKLUFTBREMSER, DRUCKLUFTBREMSER, AIR-BRAKES, FREIN HAUTE PRESSION	40
TRÆK, ZUG, DRAWBAR, ATTELAGE.....	45

Reservedelslistens opbygning, the construction of the sparepartslist

<p>Reservedelstegningerne tager udgangspunkt i en POWERROLL 1830. Ved de øvrige modeller er der udarbejdet en ekstra reservedelsliste hvor i forskellene som hovedrammer mm. fremgår</p>	<p>The spare parts drawings have their point of origin in a POWERROLL 1830. For the other models there is made an extra spare parts list, where the differences are shown.</p>	<p>Die Ersatzteilzeichnungen sind ursprünglich von der POWERROLL 1830. Für die anderen Typen gibt es eine separate Ersatzteilliste, die Unterschiede aufzeigt.</p>	<p>Les dessins des pièces détachées sont basés sur un POWERROLL 1830. Pour les autres modèles une liste supplémentaire de pièces est établie où les différences sont montrées.</p>
<p>For deres sikkerhed samt for funktionsdygtigheden af deres maskine, bør der kun anvendes originale DALBO reservedele til deres maskine</p> <p>Når de bestiller reservedele bør de altid informere om:</p> <ul style="list-style-type: none"> • Reservedelsnummer • Maskinens typenummer • Antal styk af reservedelen 	<p>For your safety and for the functions of the mashing, you should only use original spare parts from DALBO.</p> <p>When you order spare parts, you should always inform about:</p> <ul style="list-style-type: none"> • Spare part number • The mashing type number • Amount of spare parts pieces 	<p>Zu Ihrer Sicherheit und zur einwandfreien Funktion ihres Gerätes sollten sie unbedingt nur original DALBO Ersatzteile verwenden.</p> <p>Wenn sie Ersatzteile bestellen bitte folgendes beachten:</p> <ul style="list-style-type: none"> • Ersatzteil-Nummer • Geräte-Nummer und -typ • Anzahl der Ersatzteile 	<p>Pour votre sécurité et pour les fonctions du matériel, vous devez utiliser uniquement des pièces détachées d'origine DALBO.</p> <p>Lorsque vous commandez vos pièces détachées, vous devez toujours nous indiquer :</p> <ul style="list-style-type: none"> • Le numéro de la pièce • Le type de la machine • La quantité des pièces détachées.

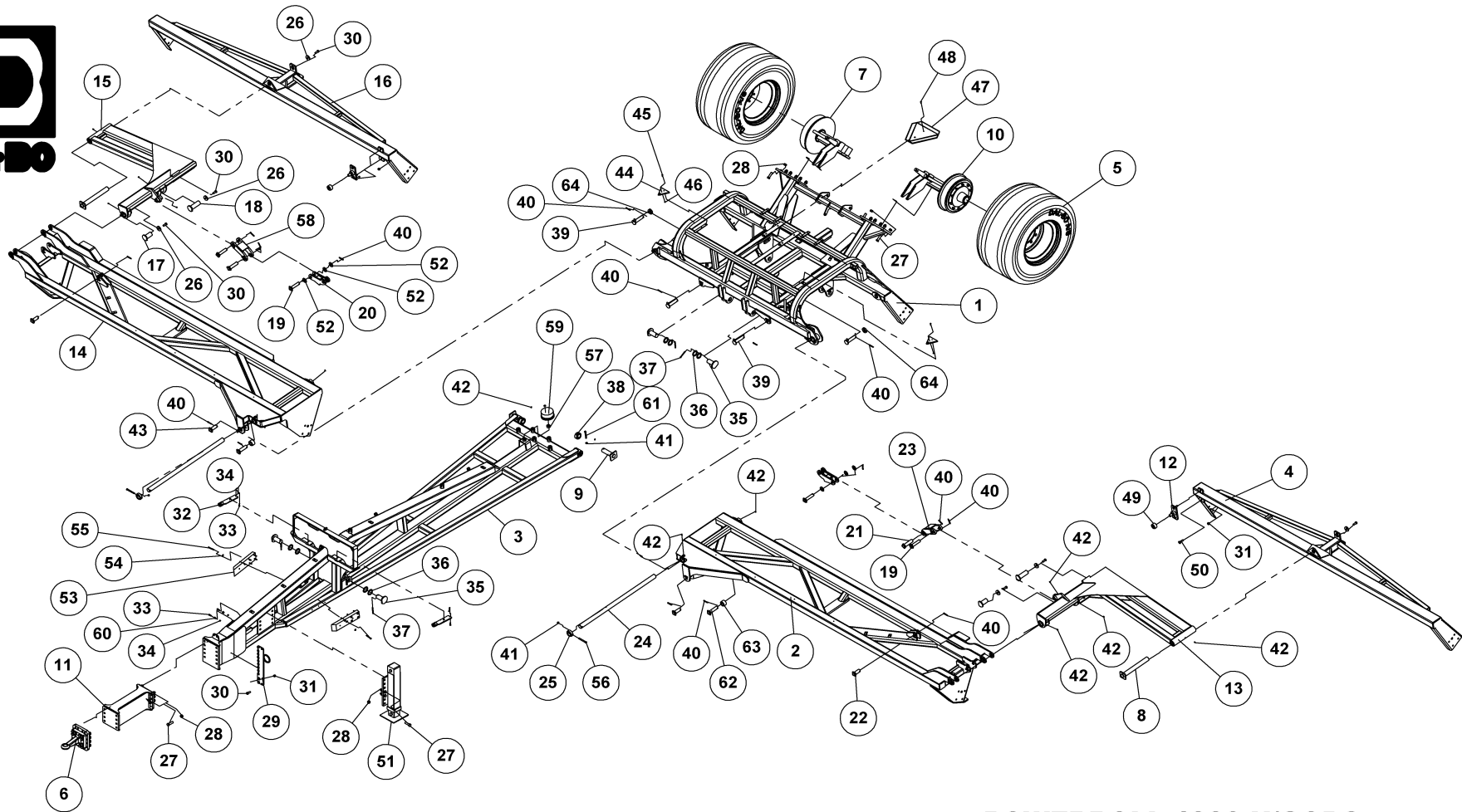

**POWERROLL 1830 U/GODS
AKSLER, LEJER OG STOPRINGE**

25092



POWERROLL 1830 U/GODS

AKSLER, LEJER OG STOPRINGE

25092

Pos.	Qty.	Part nr.	Benævnelse	Bezeichnung	Description	Designation
1	1	26546	MIDTERSEKTION 1830CM POWERROLL	MITTLERE SEKTION	MIDDLE SECTION	SECTION CENTRALE
2	1	26591	MELLEM VENSTRE SÍDESEKTION	SEITENSEKTION LINKS	SIDE SEKTION LEFT	SECTION LATÉRALE GAUCHE
3	1	26609	TRÆK 1830 POWERROLL	ZUG	DRAWBAR	ATTELAGE
4	1	26572	YDERSTE VENSTRE SÍDESEKTION	SEITENRAHMEN LINKS	SIDE FRAME, LEFT	CADRE LATÉRAL GAUCHE
5	2	80044	HJUL KPL. 600/50-22,5 FLOTATION	RAD	WHEEL	ROUE
6	1	25174	HITCH TRÆK KPL.	ZUG	DRAWBAR	ATTELAGE
7	1	33490	BREMSENAV Ø100 - 1230 HØJRE	BREMSNABE RECHTS	BRAKE HUB RIGHT	MOYEU DE FREIN/GOUPILLE GAUCHE DROITE
8	2	26506	NAGLE F Ø50X418MM	BOLZEN	PIN	AXE
9	2	25487	NAGLE F Ø50X154 - FOR LÅSEBØSNING	BOLZEN	PIN	AXE
10	1	33489	BREMSENAV Ø100 - 1230 VENSTRE	BREMSNABE LINKS	BRAKE HUB LEFT	MOYEU DE FREIN/GOUPILLE GAUCHE
11	1	25483	TRÆKFORLÆNGER 600 MM	ZUG VERLÄNGERUNG	DRAWBAR EXTENSION	ALLONGEMENT D'ATTELAGE
12	2	26646	TAP TIL LEJE UNDERSÆNKET	WELLE	SHAFT	ARBRE
13	1	26644	SVINGARM VENSTRE 1830CM	MOBILARM	MOBILEARM	BRAS MOBILE
14	1	26590	MELLEM HØJRE SÍDESEKTION	SEITENSEKTION RECHTS	SIDE SEKTION RIGHT	SECTION LATÉRALE DROITE
15	1	26645	SVINGARM HØJRE 1830CM	MOBILARM	MOBILEARM	BRAS MOBILE
16	1	26573	YDERSTE HØJRE SÍDESEKTION	SEITENRAHMEN LINKS	SIDE FRAME, LEFT	CADRE LATÉRAL GAUCHE
17	2	25482	NAGLE F Ø50X95(105) 25482	BOLZEN	PIN	AXE
18	2	25481	NAGLE F Ø50X145(155) 25481	BOLZEN	PIN	AXE
19	4	25452	NAGLE F Ø30X120(148)	BOLZEN	PIN	AXE
20	2	25510	VIPPEARM NEDERSTE 1630CM	WIPPARM	ROCKER ARM	BRAS BASCULANTE
21	2	72286	NAGLE F Ø35X120(148)	BOLZEN	PIN	AXE
22	2	80448	NAGLE F Ø35X70 (93)	BOLZEN	PIN	AXE
23	1	25554	VIPPEARM YDERST VENSTRE	WIPPARM	ROCKER ARM	BRAS BASCULANTE
24	2	25854	NAGLE U Ø50X1275 MM - MINIMAX 1830	BOLZEN	PIN	AXE
25	2	25607	BØSNING TIL NAGLE MIDTERSEKTION	BUCHSE	BUSHING	DOUILLE
26	6	71570	SKIVE Ø17,5-Ø61-10	SCHEIBE	WASHER	RONDELLE
27	26	92342	BOLT M20X70 MM 8.8 GALV.	SCHRAUBE	SCREW	BOULON
28	26	92052	MØTRIK M20, SELVLÅS, GALV. KV. 8.8	MUTTER SELBSTGESICHERT	SELF-LOCKING NUT	ÉCROU DE SÉCURITÉ
29	1	41218	SLANGEHOLDER, SV	SCHLAUCHHALTER	HOSE CLAMP	SUPPORT DE TUYAU
30	8	92316	BOLT M16X40 MM 8.8 GALV.	SCHRAUBE	SET SCREW	BOULON
31	6	92051	MØTRIK M16, SELVLÅS, GALV. KV. 8.8	MUTTER	NUT	ÉCROU
32	2	25446	HYDRAULIKBLOK	HYDR. BLOCK	HYDRAULIC BLOCK	BLOC HYDRAULIQUE
33	6	92261	BOLT M8X30, U/SKAFT GALV. KV. 8.8	SCHRAUBE	SCREW	BOULON
34	6	92048	MØTRIK M8, SELVLÅS, GALV. KV. 8.8	MUTTER	NUT	ÉCROU
35	4	41197	NAGLE Ø49,6X95	BOLZEN	PIN	AXE
36	8	51349	SKIVE Ø51-Ø75-3 Giv	SCHEIBE	WASHER	RONDELLE
37	4	90678	SPLIT Ø8X71 MM GALV.	SPLINTE	SPLIT PIN	GOUPILLE
38	2	25488	BØSNING- STOP FOR NAGLE	BUCHSE	BUSHING	DOUILLE
39	4	90122	NAGLE Ø34,5X130	BOLZEN	PIN	AXE
40	16	90677	SPLIT 8X50 MM GALV.	SPLINT	SPLIT PIN	GOUPILLE
41	4	92050	MØTRIK M12, SELVLÅS, GALV. KV. 8.8	MUTTER SELBSTSCHLIESSEND	SELFLOCKING NUT	ÉCROU DE SÉCURITÉ
42	14	90721	SMØRENIPPPEL LIGE M8x1 MM	SCHMIERNIPPPEL	GREASE NIPPLE	GRAISSEUR
43	2	74308	NAGLE F Ø35X80(108)	BOLZEN	PIN	AXE
44	2	90923	REFLEX RØD JUR 472 PLAST	REFLEX	REFLEX	REFLET
45	4	92249	SKRUE M6X25, PH TORX GALV. KV. 8.8	SCHRAUBE	SCREW	BOULON
46	4	92027	MØTRIK M6, GALV. KV. 8.8	MUTTER	NUT	ÉCROU
47	1	34213	ADVARSLSREFLEKS - STOR	WARN DREIECK	WARNING TRIANGLE	ECRITEAU AVERTISSEUR
48	2	92247	BOLT M6X20, FLANGE GALV. KV. 8.8	SCHRAUBE	SCREW	BOULON
49	2	25390	NYLONLEJE TIL YDERVINGE	LAGER	BEARING	FIXATION
50	4	92420	BOLT M16X60, UNDERSÆNKET GALV. KV. 8.8	SCHRAUBE	COUNTERSUNK SCREW	BOULON
51	1	25556	STØTTEBEN HYDRAULISK M. FLANGE	STÜTZFUSS	JACK	BEQUILLE
52	6	90662	SKIVE Ø31-Ø62-2,5	UNTERLEGSSCHEIBE	WASHER	RONDELLE DE SERRAGE
53	2	37685	GODS HVILER STÅLTROMLE	STÜTZE	SUPPORT	FIXATION
54	12	90668	SKIVE Ø10,5/Ø20X2 MM	UNTERLEGSSCHEIBE	WASHER	RONDELLE DE SERRAGE
55	12	92265	BOLT M8X80, M/SKAFT GALV. KV. 8.8	SCHRAUBE	SCREW	BOULON

**POWERROLL 1830 U/GODS****AKSLER, LEJER OG STOPRINGE****25092**

Pos.	Qty.	Part nr.	Benævnelse	Bezeichnung	Description	Designation
56	2	92304	BOLT 12x120 8.8 GALV.	SCHRAUBE	SCREW	BOULON
57	1	92033	MØTRIK M24, GALV. KV. 8.8	MUTTER	NUT	ÉCROU
58	1	25555	VIPPEARMS YDERST HØJRE	WIPPARM	ROCKER ARM	BRAS BASCULANTE
59	1	85430	GUMMIDÆMPER 148X60, M24	GUMMIKLOTZ	RUBBER BLOCK	BLOC EN CAOUTCHOUC
60	4	90631	SP.SKIVE M8 Ø8,5/Ø30X1,50 GLV.	UNTERLEGSSCHEIBE	WASHER	RONDELLE DE SERRAGE
61	2	92302	BOLT 12x100 8.8 GALV.	SCHRAUBE	SCREW	BOULON
62	2	37910	NAGLE F Ø35X115	BOLZEN	PIN	AXE
63	2	26586	BØSNING POWERROLL	BUCHSE	BUSHING	DOUILLE
64	2	26567	BØSNING POWERROLL MINI	BUCHSE	BUSHING	DOUILLE

Gods på aksel 1830 Cambridge Snowflake 55, Metal on shaft, Giessgut auf Wellen, Metal sur arbres

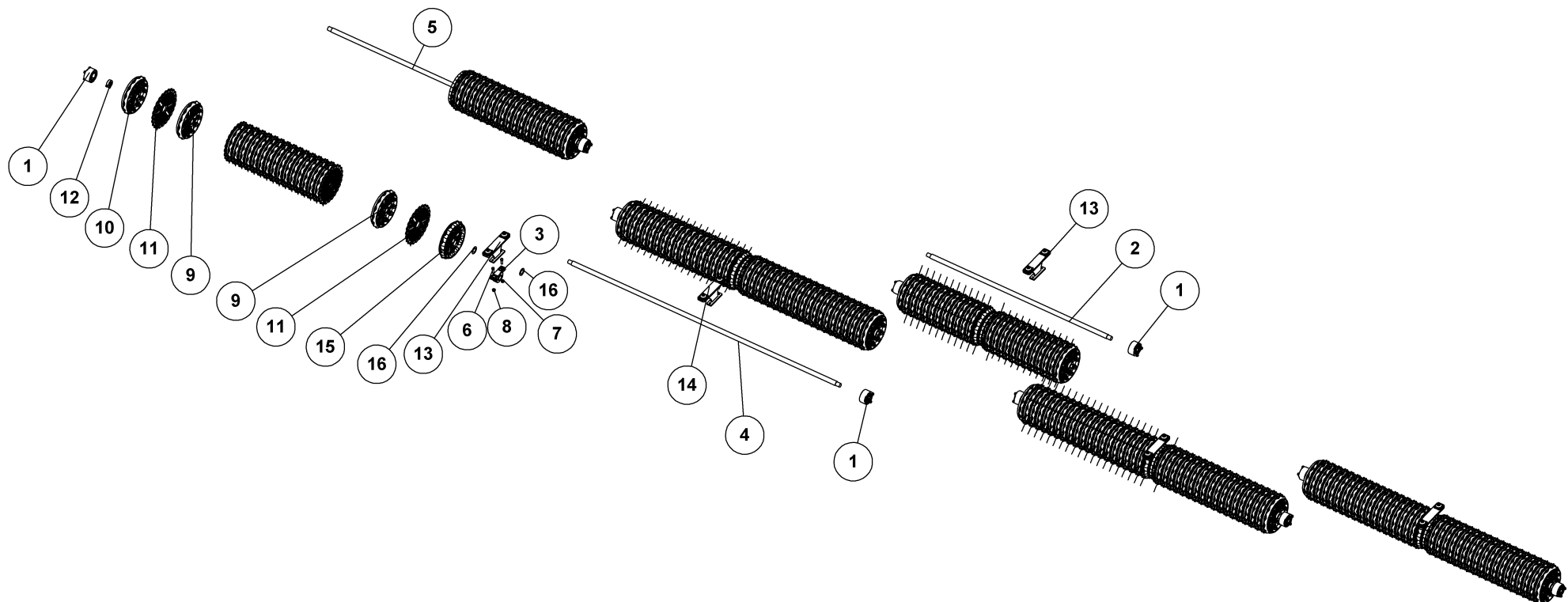

SÆT GODS PÅ AKSLER 1830X55 CAMBRIDGE SNOWFLAKE

SATZ GIESSGUT FÜR DIE WELLEN
METAL SET FOR AXLE
MÉTAL SUR ARBRES

25130-7

SÆT GODS PÅ AKSLER 1830X55 CAMBRIDGE SNOWFLAKE

25130-7

Pos.	Qty.	Part nr.	Benævnelse	Bezeichnung	Description	Designation
1	10	12434	GUMMILEJE - KPL.	LAGER	BEARING	FIXATION
2	1	23386	AKSEL Ø60X2940	WELLE	SHAFT	ARBRE
3	5	12459	KOMPLET STÅLEJE Ø60 MM - SKF SYJ65KF+H2313.	KOMPLETTES STEH LAGER	COMPLETE STEEL BEARING	PALIER COMPLET
4	2	25852	AKSEL Ø60 L= 4340 CRMO4V	WELLE	SHAFT	ARBRE
5	2	25853	AKSEL Ø60 L= 4140 CRMO4V	WELLE	SHAFT	ARBRE
6	10	92342	BOLT M20X70 MM 8.8 GALV.	SCHRAUBE	SCREW	BOULON
7	10	90664	SPÆND. SKIVE Ø39 X Ø23 X 3	UNTERLEGSCHIEBE	SEALING WASHER	RONDELLE DE SERRAGE
8	10	92052	MØTRIK M20, SELVLÅS. GALV. KV. 8.8	MUTTER SELBSTGESICHERT	SELF-LOCKING NUT	ÉCROU DE SÉCURITÉ
9	162	15784	55 CM GLAT RING - SNOWFLAKE	SATZ RINGE FÜR DIE ACHSE	SHAFT RING SET	ANNEAUX SUR ARBRE
10	10	15788	55 CM GLAT ENDERING AFDREJET - SNOWFLAKE	GLATTER ENDRING	SMOOTH ENDRING	ANNEAU FIN LISSE
11	172	15785	Ø55 CM TAKKET RING - SNOWFLAKE	GEZAHNTER RING - ATG	NOTCHED RING	ANNEAU DENTÉ -
12	10	12334	STOPRING Ø 60 KPL.	ANSCHLAGRING	STOP BUSHING	BAGUE D'ARRÊT
13	3	25913	LEJE OPHÆNGMED GUMMIAFFJEDRING	LAGERBEFESTIGUNG	BEARING PLATE	FIXATION DE PALIER
14	2	25910	LEJE OPHÆNG MED GUMMIAFFJEDRING	LAGERBEFESTIGUNG	BEARING PLATE	FIXATION DE PALIER
15	10	15789	55 CM GLAT MIDTERLEJERING - SNOWFLAKE	SATZ RINGE FÜR DIE ACHSE	SHAFT RING SET	ANNEAUX SUR ARBRE
16	30	90667	SKIVE Ø62-Ø101-2	SCHIEBE	WASHER	RONDELLE

SÆT GODS PÅ AKSLER 1830X50 CAMBRIDGE SNOWFLAKE

25129-7

Pos.	Qty.	Part nr.	Benævnelse	Bezeichnung	Description	Designation
11	10	33549	RING KPL. FOR MIDTERLEJE Ø50	SCHIEBE	DISC. SMOOTH	RONDELLE
12	172	15184	50 CM GLAT RING - SNOWFLAKE	GLATTER RING	SMOOTH RING	ANNEAU LISSE
13	10	15188	50 CM GLAT ENDERING AFDREJET	GLATTER ENDRING	SMOOTH RING	ANNEAU LISSE
14	172	15185	50 CM TAKKET RING - SNOWFLA	GEZAHNTER RING	NOTCHED RING	ANNEAU DENTE

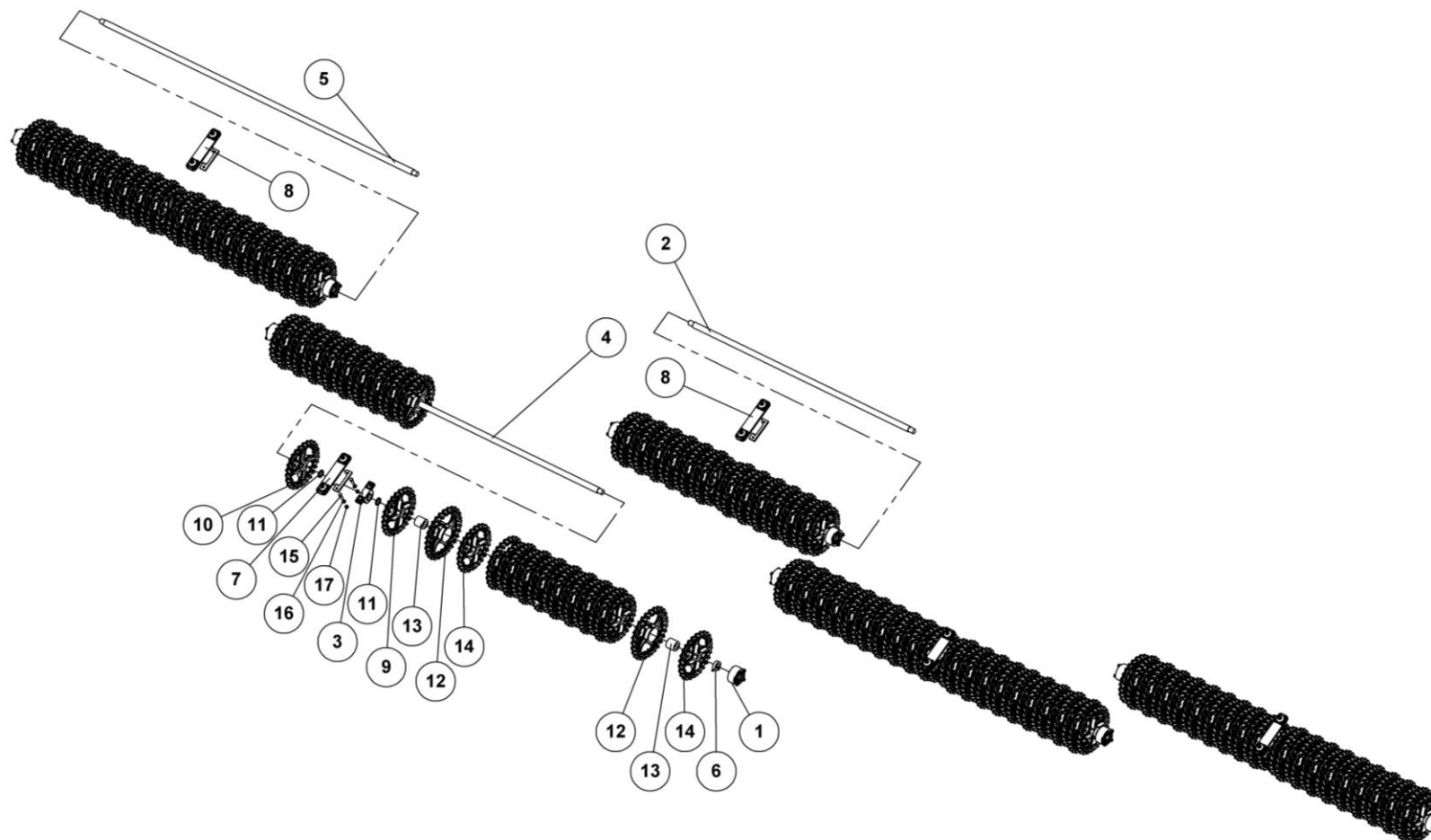

SÆT GODS PÅ AKSLER 1830X60 CROSSKILL

SATZ GIESSGUT FÜR DIE WELLEN
METAL SET FOR AXLE
METAL SUR ARBRES

25168



SÆT GODS PÅ AKSLER 1830X60 CROSSKILL

25168

SATZ GIESSGUT FÜR DIE WELLEN
METAL SET FOR AXLE
MÉTAL SUR ARBRES

Pos.	Qty.	Part nr.	Benævnelse	Bezeichnung	Description	Designation
1	10	12434	GUMMILEJE - KPL.	LAGER	BEARING	FIXATION
2	1	23386	AKSEL Ø60X2940	WELLE	SHAFT	ARBRE
3	5	12459	KOMPLET STÅLEJE Ø60 MM - SKF SYJ65KF+H2313.	KOMPLETTES STEH LAGER	COMPLETE STEEL BEARING	PALIER COMPLET
4	2	25852	AKSEL Ø60 L= 4340 CRMO4V	WELLE	SHAFT	ARBRE
5	2	25853	AKSEL Ø60 L= 4140 CRMO4V	WELLE	SHAFT	ARBRE
6	10	12334	STOPRING Ø 60 KPL.	ANSCHLAGRING	STOP BUSHING	BAGUE D'ARRÊT
7	2	25910	LEJE OPHÆNG MED GUMMIAFFJEDRING	LAGERBEFESTIGUNG	BEARING PLATE	FIXATION DE PALIER
8	3	25913	LEJE OPHÆNGMED GUMMIAFFJEDRING	LAGERBEFESTIGUNG	BEARING PLATE	FIXATION DE PALIER
9	5	18128	CROSSKILL RING Ø550- SMAL HØJRE	CROSSKILL SCHMAL RECHTS	CROSSKILL, NARROW RIGHT	CROSSKILL - ÉTROIT DROITE
10	5	18129	CROSSKILL RING Ø550- SMAL VENSTRE	CROSSKILL SCHMAL LINKS	CROSSKILL, NARROW LEFT	CROSSKILL - ÉTROIT GAUCHE
11	10	93130001090L90L	AFSTANDSSTYKKE Ø80XØ63 L=10MM	ABSTANDSSTÜCK	SPACER	ENTRETOISE
12	86	18126	CROSSKILL RING Ø600/160	CROSSKILL RING	CROSSKILL RING	ANNEAU CROSSKILL
13	86	18127	CROSSKILL BØSNING Ø104/62	CROSSKILL BUCHSE	CROSSKILL BUSHING	DOUILLE CROSSKILL
14	86	18125	CROSSKILL RING Ø550/62	CROSSKILL RING	CROSSKILL RING	ANNEAU CROSSKILL
15	10	92342	BOLT M20X70 MM 8.8 GALV.	SCHRAUBE	SCREW	BOULON
16	10	90644	SPÆND. SKIVE Ø37 X Ø21 X 3	UNTERLEGSCHEIBE	SEALING WASHER	RONDELLE DE SERRAGE
17	10	92052	MØTRIK M20, SELVLÅS, GALV. KV. 8.8	MUTTER SELBSTGESICHERT	SELF-LOCKING NUT	ÉCROU DE SÉCURITÉ

SÆT GODS PÅ AKSLER 1830X53CM

CROSSKILL

25169

Pos.	Qty.	Part nr.	Benævnelse	Bezeichnung	Description	Designation
9	5	18108	CROSSKILL Ø480 - SMAL HØJRE	CROSSKILL SCHMAL RECHTS	CROSSKILL NARROW RIGHT	CROSSKILL - ÉTROIT DROITE
10	5	18109	CROSSKILL Ø480 - SMAL VENSTRE	CROSSKILL SCHMAL LINKS	CROSSKILL NARROW LEFT	CROSSKILL ÉTOIT GAUCHE
12	86	18102	CROSSKILL RING Ø530/160	CROSSKILL RING	CROSSKILL RING	ANNEAU CROSSKILL
13	86	18103	CROSSKILL BØSNING Ø90/62	CROSSKILL BUCHSE	CROSSKILL BUSHING	DOUILLE CROSSKILL
14	86	18101	CROSSKILL RING Ø480/62	CROSSKILL RING	CROSSKILL RING	ANNEAU CROSSKILL

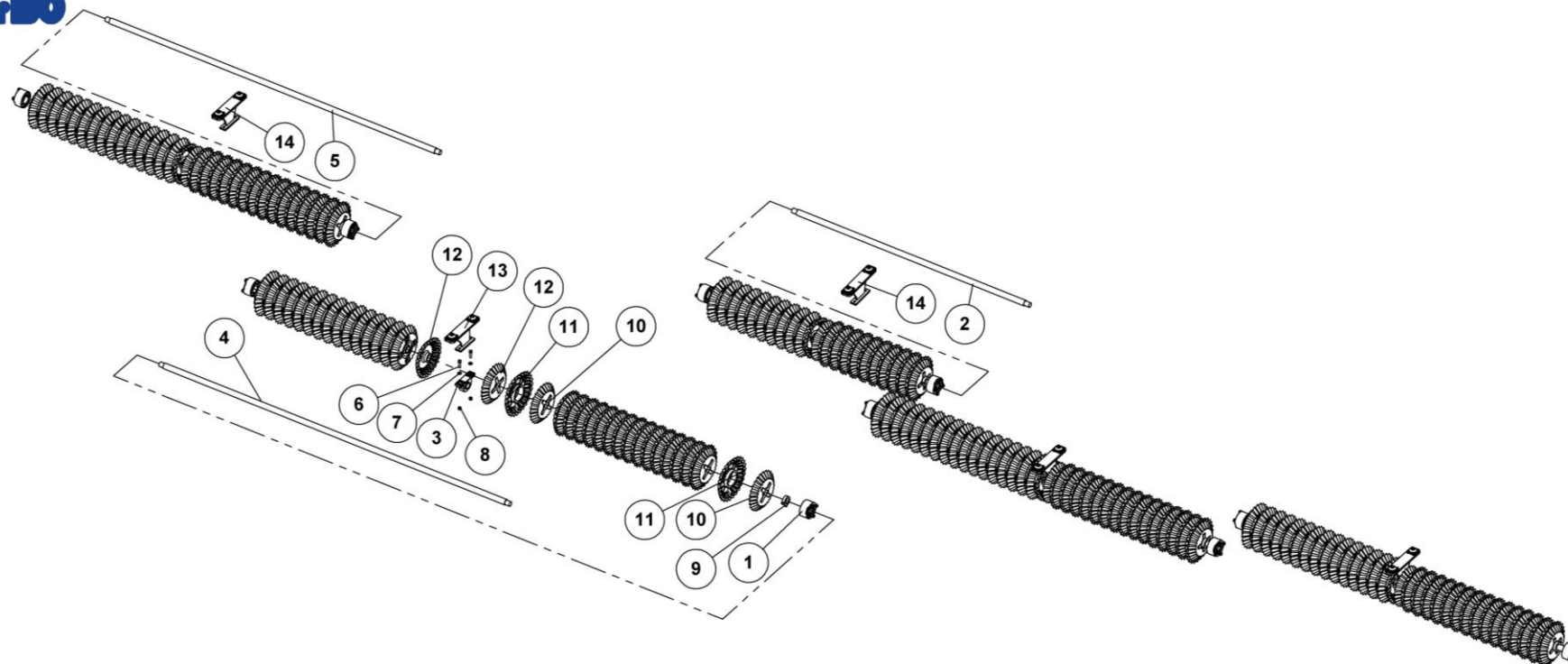

**SÆT GODS PÅ AKSLER 1830X50
CROSS COMBI**

SATZ GIESSGUT FÜR DIE WELLEN
METAL SET FOR AXLE
MÉTAL SUR ARBRES

25335

**SÆT GODS PÅ AKSLER 1830X50****CROSS COMBI****25335**SATZ GIESSGUT FÜR DIE WELLEN
METAL SET FOR AXLE
MÉTAL SUR ARBRES

Pos.	Qty.	Part nr.	Benævnelse	Bezeichnung	Description	Designation
1	10	12434	GUMMILEJE - KPL.	LAGER	BEARING	FIXATION
2	1	23386	AKSEL Ø60X2940	WELLE	SHAFT	ARBRE
3	5	12459	KOMPLET STÅLEJE Ø60 MM - SKF SYJ65KF+H2313.	KOMPLETTES STEH LAGER	COMPLETE STEEL BEARING	PALIER COMPLET
4	2	25852	AKSEL Ø60 L= 4340 CRMO4V	WELLE	SHAFT	ARBRE
5	2	25853	AKSEL Ø60 L= 4140 CRMO4V	WELLE	SHAFT	ARBRE
6	10	92342	BOLT M20X70 MM 8.8 GALV.	SCHRAUBE	SCREW	BOULON
7	10	90664	SPÆND. SKIVE Ø39 X Ø23 X 3	UNTERLEGSCHIEBE	SEALING WASHER	RONDELLE DE SERRAGE
8	10	92052	MØTRIK M20, SELVLÅS, GALV. KV. 8.8	MUTTER SELBSTGESICHERT	SELF-LOCKING NUT	ÉCROU DE SÉCURITÉ
9	10	12334	STOPRING Ø 60 KPL.	ANSCHLAGRING	STOP BUSHING	BAGUE D'ARRÊT
10	144	18060	CROSS - COMBI Ø450 MM	SATZ RINGE FÜR DIE ACHSE	SHAFT RING SET	ANNEAUX SUR ARBRE
11	144	18061	CROSS - COMBI Ø500 MM	SATZ RINGE FÜR DIE ACHSE	SHAFT RING SET	ANNEAUX SUR ARBRE
12	10	18059	CROSS - COMBI Ø450 MM - AFDREJET 60 MM	SATZ RINGE FÜR DIE ACHSE	SHAFT RING SET	ANNEAUX SUR ARBRE
13	2	25910	LEJE OPHÆNG MED GUMMIAFFJEDRING	LAGERBEFESTIGUNG	BEARING PLATE	FIXATION DE PALIER
14	3	25913	LEJE OPHÆNGMED GUMMIAFFJEDRING	LAGERBEFESTIGUNG	BEARING PLATE	FIXATION DE PALIER

SÆT GODS PÅ AKSLER 1530X55CM**CROSS COMBI****25356**

Pos.	Qty.	Part nr.	Benævnelse	Bezeichnung	Description	Designation
9	144	18160	CROSS-COMBI Ø500 MM	CROSS-COMBI RING	CROSS-COMBI RING	ANNEAU CROSS-COMBI
10	144	18161	CROSS-COMBI Ø550 MM	CROSS-COMBI RING	CROSS-COMBI RING	ANNEAU CROSS-COMBI
11	10	18159	CROSS-COMBI Ø500 MM - AFDREJET 60 MM	CROSS-COMBI RING	CROSS-COMBI RING	ANNEAU CROSS-COMBI

Leje kpl. Bearing cpl. Lager kpl. Palier cpl.

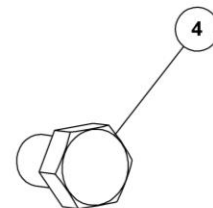
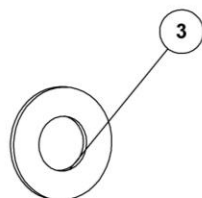
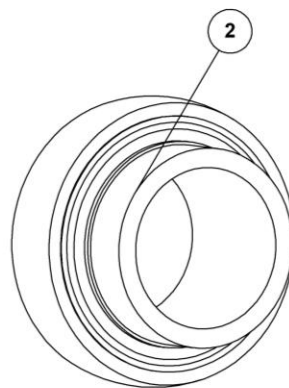
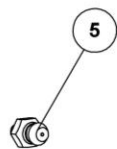
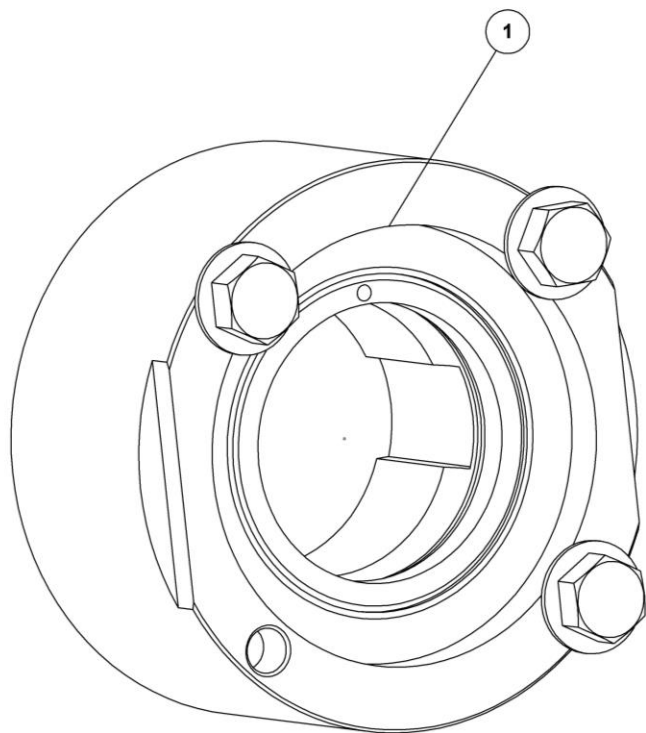

**GUMMILEJE - KPL.
SMØRING**

LAGER
BEARING
FIXATION

12434



GUMMILEJE - KPL.

LAGER
BEARING
FIXATION

SMØRING

12434

Vare nr.	Vare navn	Vare type	Varegruppe	Færdig meldt	Linie type	Stop	Linie rabat	Rå vare nr.	Rå varenavn	Pos nr.	Operation	Antal	Skære længde	Bredde	Specification
12432	LEJEHUS - AFFJEDRET	Vare	069	Ja	Vare	Nej	Reserve	12432	LEJEHUS - AFFJEDRET	1	Samle	1	1	1	
12449	LEJE Ø 50 SKF YAR 210 2RF	Vare	069 FÆLLES DELE	Ja	Vare	Nej	Reserve			2	Samle	1	1	1	
90663	SKIVE Ø17/Ø35X2 MM	Vare	069	Nej	Vare	Nej	Reserve	90663	SP.SKIVE M16 Ø35/17X2 GLV.	3	Samle	4	1	1	
92311	BOLT 16X25 MM 8.8 GALV.	Vare	103 BOLTE, MØTRIKKER.	Nej	Vare	Nej	Reserve	92311	BOLT 16x25 8.8 GALV. (SÆTBOLT)	4	Samle	4	1	1	
75889	SMØRENIPPEL M6X1 K	Vare	069 FÆLLES DELE	Nej	Vare	Nej	Reserve	75889	SMØRENIPPEL M6X1 K	5	Samle	1	1	1	

Lejefæste med dæmpning. Bearing Plate. Lagerbefestigung. Fixation de palier.

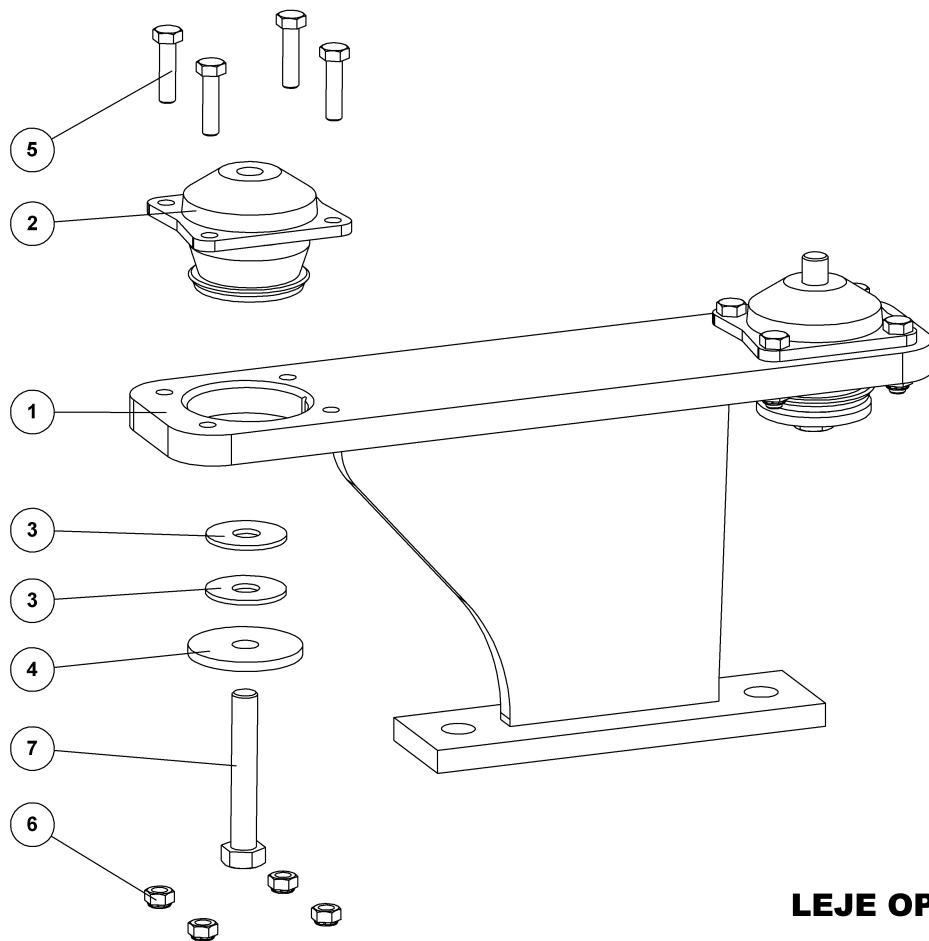

**LEJE OPHÆNG MED GUMMIAFFJEDRING
MIDDERSTE SIDESEKTION POWERROLL**

LAGERBEFESTIGUNG
BEARING PLATE
FIXATION DE PALIER

25910



LEJE OPHÆNG MED GUMMIAFFJEDRING MIDDERSTE SIDESEKTION POWERROLL 25910

LAGERBEFESTIGUNG
BEARING PLATE
FIXATION DE PALIER

Pos.	Qty.	Part nr.	Benævnelse	Bezeichnung	Description	Designation
1	1	25909	LEJE OPHÆNG INDERSTE SIDESEKTION	AUFHÄNGUNG	LINKAGE	SUSPENSION
2	2	33741	DÆMPER (METACONE) 70 IRH	GUMMIKLOTZ	RUBBER BLOCK	BLOC EN CAOUTCHOUC
3	4	90658	SKIVE Ø17-Ø50-3	UNTERLEGSCHIEBE	WASHER	RONDELLE DE SERRAGE
4	2	33742	SKIVE Ø71/Ø16,5/6 MM, DÆMPER 33741	SCHEIBE	WASHER	RONDELLE
5	8	92275	BOLT M10X40, M/SKAFTE GALV. 8.8			
6	8	92049	MØTRIK M10, SELVLÅS. GALV. KV. 8.8	MUTTER	SELF-LOCKING NUT	ÉCROU
7	2	92322	BOLT M16X100 MM, 8.8 GALV.	SCHRAUBE	SCREW	BOULON

LEJE OPHÆNG MED GUMMIAFFJEDRING

YDERSTE OG MIDTERSTE SEKTION

25913

Pos.	Qty.	Part nr.	Benævnelse	Bezeichnung	Description	Designation
1	1	25913	LEJE OPHÆNG MIDT OG YDERSTE SEKTIONER	LAGERBEFESTIGUNG	BEARING PLATE	FIXATION DE PALIER

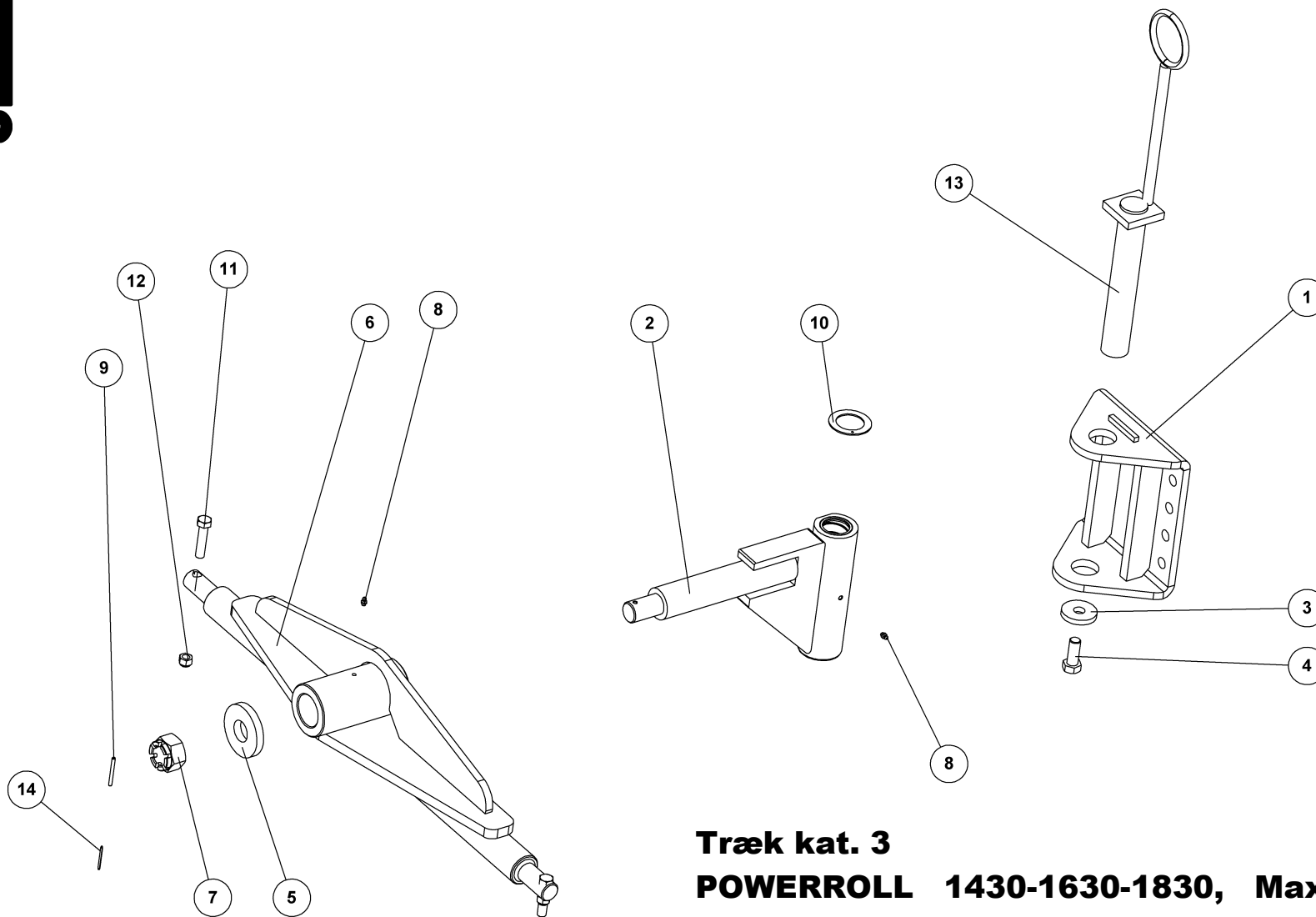

Træk kat. 3
POWERROLL 1430-1630-1830, MaxiRoll HD
1230

ATTELAGE
DRAWBAR



Træk kat. 3

ATTELAGE
DRAWBAR
ZUG

POWERROLL 1430-1630-1830, MaxiRoll HD 1230

25270

Pos.	Qty.	Part nr.	Benævnelse	Bezeichnung	Description	Designation
1	1	25262	FLANGE TIL TRÆK KPL.	FLANSCHEN	FLANGE	AILE
2	1	74272	TRÆK NAV	ZUG	DRAWBAR HUB	ATTELAGE
3	1	74529	SKIVE Ø21-Ø69-10	UNTERLEGSCHIEBE	WASHER	RONDELLE DE SERRAGE
4	1	92335	BOLT 20x50 8.8 GALV. (S/ETBOLT)	SCHRAUBE	SET SCREW	BOULON
5	1	71380	SKIVE Ø41-Ø100-15	SCHIEBE	WASHER	RONDELLE
6	1	74274	TRÆK KAT. 3 AXR-H	ZUG	DRAWBAR	ATTELAGE
7	1	72384	AKSELMØTRIK M39x3, NV 60 GLV. KI.8	ACHSENMUTTER	SHAFT NUT	ÉCROU D'ARBRE
8	2	90721	SMØRENIPPEL LIGE M8x1 MM	SCHMIERNIPPEL	GREASE NIPPLE	GRAISSEUR
9	1	90688	RØRSTIFT Ø 6X60 MM	ROHRSTIFT	SPLIT PIN	AXE TUBULAIRE
10	2	71251	FORMURT TRYKSKIVE - Ø78/Ø52/2,6MM	VORGESCHMIERTE DRUCKSCHIEBE	GREASED THRUST WASHER	RONDELLE DE PRESSION LUBRIFIÉE D'USINE
11	2	92319	BOLT 16x70 8.8 GALV.	SCHRAUBE	SCREW	BOULON
12	2	92051	MØTRIK M16 SELVLÅS. GLV.8	MUTTER	NUT	ÉCROU
13	1	74304	NAGLE F Ø50X298	BOLZEN	PIN	AXE
14	1	90689	RØRSTIFT Ø3,5X50	ROHRSTIFT	SPLIT PIN	AXE TUBULAIRE

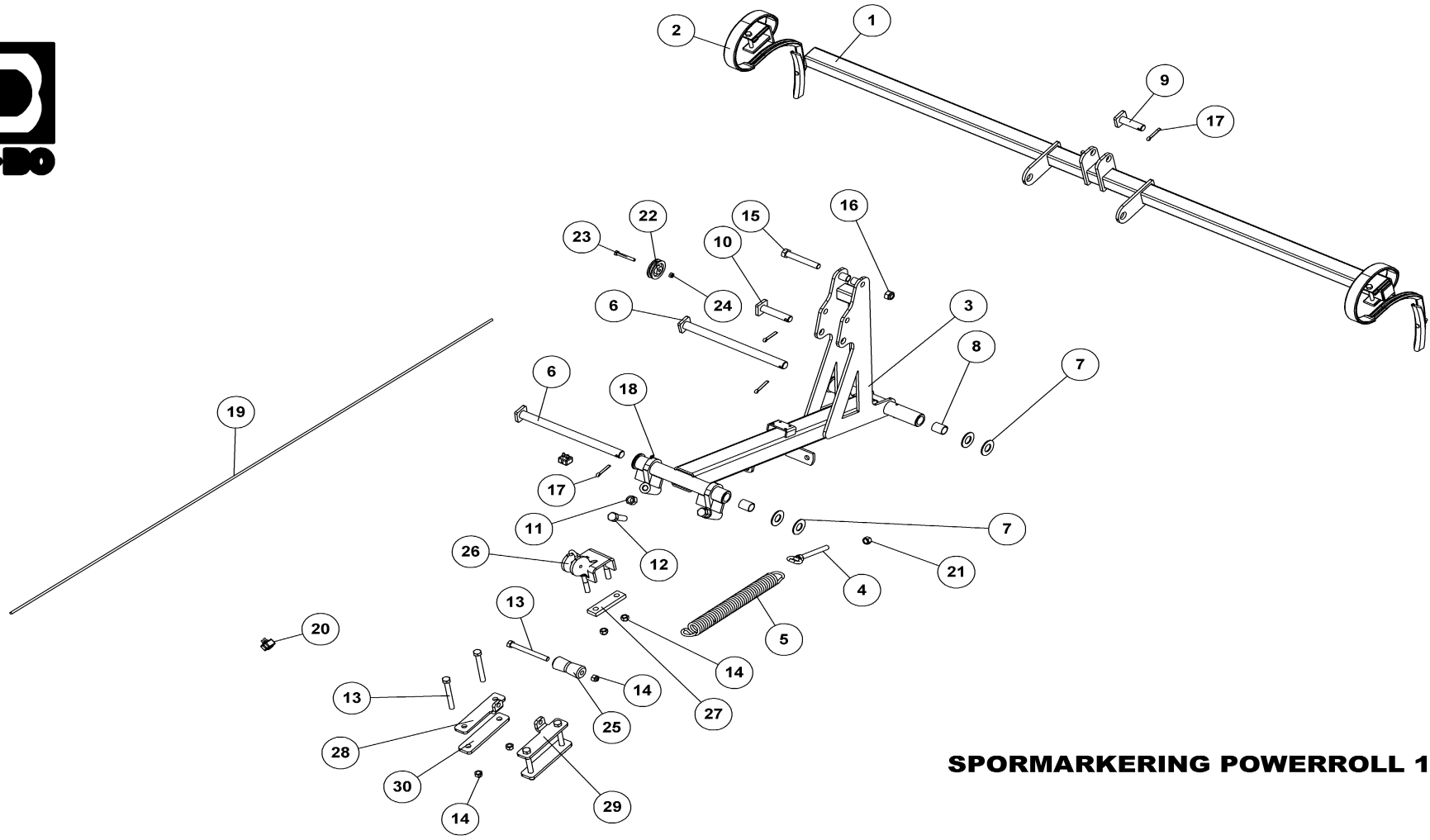

SPORMARKERING POWERROLL 1830

SPURANREISSER KOMPLETT
COMPLETE MARKER ARM
MARQUEUSE COMPLETE

25191



SPORMARKERING POWERROLL 1830

25191

SPURANREISSER KOMPLETT
COMPLETE MARKER ARM
MARQUEUSE COMPLÈTE

Pos.	Qty.	Part nr.	Benævnelse	Bezeichnung	Description	Designation
1	1	25397	BOM FOR SPORMARKERING	RAHME	FRAME	CADRE
2	2	39072	KULTURHARVETAND 45X10 KPL. M/BESLAG	ZINKEN	SPRING TINE	DENT DE HERSE
3	1	25398	UDLIGGERARM FOR SPORMARKERING	ARM	ARM	BRAS
4	1	12484	GEVINDSTANG MED KÆDE. (L= 30)	REGULIERBARE STANGE	ADJUSTABLE BAR	RÉGLABLE SUPPORT
5	1	90731	FJEDER 8X52.5X420 GALV. KP.	FEDER	SPRING	RESSORT
6	2	74317	NAGLE F. Ø30X400(428)	BOLZEN	PIN	AXE
7	8	90662	SKIVE Ø62-Ø31-3,5 GALV	SCHEIBE	WASHER	RONDELLE
8	4	91905	GLACIERLEJE PM3040DX	GLEITLAGER	PLAIN BEARING	PALIER ENDURCI
9	1	74312	NAGLE F. Ø25X75(103)	BOLZEN	PIN	AXE
10	1	74318	NAGLE F. Ø25X100(128)	BOLZEN	PIN	AXE
11	2	92032	MØTRIK M20. GALV. KV. 8.8	MUTTER	NUT	ÉCROU
12	2	92342	BOLT M20X70 MM 8.8 GALV.	SCHRAUBE	SCREW	BOULON
13	5	92327	BOLT 16X150 MM 8.8 GALV.	SCHRAUBE	SCREW	BOULON
14	7	92051	MØTRIK M16. SELVLÅS. GALV. KV. 8.8	MUTTER	NUT	ÉCROU
15	1	92341	BOLT 20x130 8.8 GALV.	SCHRAUBE	SCREW	BOULON
16	1	92052	MØTRIK M20. SELVLÅS. GALV. KV. 8.8	MUTTER SELBSTGESICHERT	SELF-LOCKING NUT	ÉCROU DE SÉCURITÉ
17	4	90677	SPLIT 8X50 MM GALV.	SPLINT	SPLIT PIN	GOUPILLE
18	2	90721	SMØRENIPPEL LIGE M8x1 MM	SCHMIERNIPPEL	GREASE NIPPLE	GRAISSEUR
19	1	9070505750XXXXXX	8 MM STÅLWIRE 6X36 IWRC	DRAHTSEIL	WIRE	FIL DE FER
20	2	90784	WIRELÅS IRON GRIP 7-8 MM	DRAHT RIEGEL	WIRE ROPE LOCK	SERRURE DE FIL DE FER
21	1	92031	MØTRIK M16 GALV. KV. 8.8	MUTTER	NUT	ÉCROU
22	1	55620	RULLE TIL WIRE	ROLLE FÜR DAS DRAHTSEIL	WIRE ROLLER	ROULEAU POUR FIL EN FER
23	1	92278	BOLT M10X70. M/SKAFT GALV. KV. 8.8	SCHRAUBE	SCREW	BOULON
24	1	92049	MØTRIK M10. SELVLÅS. GALV. KV. 8.8	MUTTER	SELF-LOCKING NUT	ÉCROU
25	1	23983	NYLON RULLE -> WIRE GUIDE	ROLLE FÜR DAS DRAHTSEIL	WIRE ROLLER	ROULEAU POUR FIL EN FER
26	1	25899	BESLAG HOLDER FOR RULLE GALV.	BESCHLAG	MOUNTING PLATE	FIXATION
27	1	26354	SPÆNDEPLADE Ø17,5X98	SPANNSTÜCK	FASTENING PLATE	PLAQUE
28	1	25977	PLADE NYLONRULLE HØJRE GALV	BESCHLAG	MOUNTING PLATE	FIXATION
29	1	25978	PLADE NYLONRULLE VENSTRE GALV	BESCHLAG	MOUNTING PLATE	FIXATION
30	2	25896	SPÆNDEPLADE GALV.	PLATTE	FASTENING PLATE	PLAQUE

Lygtesæt, leuchtssatz, light set, ensemble de phares

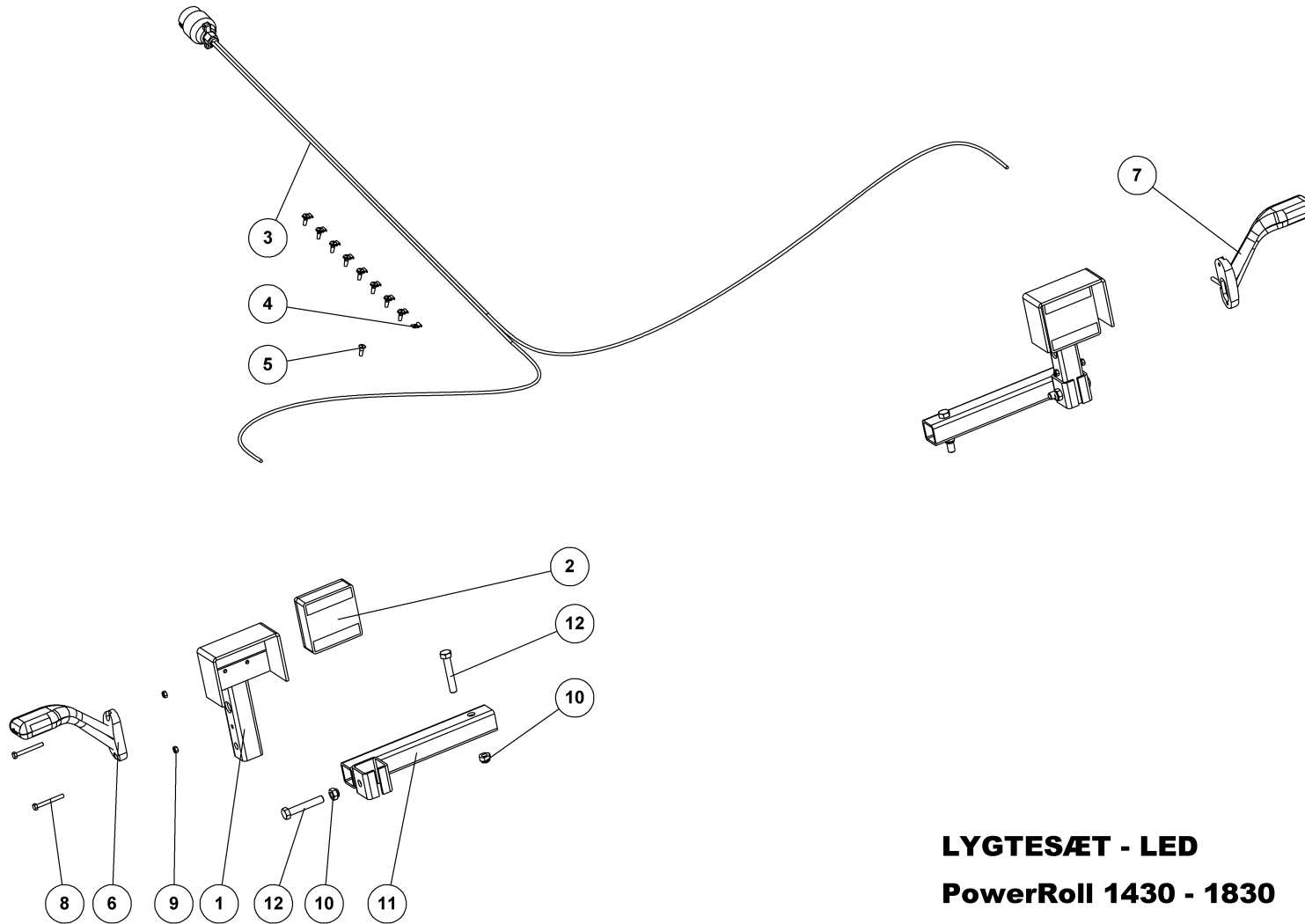

LYGTESÆT - LED
PowerRoll 1430 - 1830

LEUCHTSSATZ
LIGHT SET
ENSEMBLE DE PHARES

25363



LYGTESÆT - LED

LEUCHTSSATZ
LIGHT SET
ENSEMBLE DE PHARES

PowerRoll 1430 - 1830

25363

Pos.	Qty.	Part nr.	Benævnelse	Bezeichnung	Description	Designation
1	2	71454	LYGTESTANDER FÆLLES	LEUCHTSTÄNDER	LIGHT STAND	BÂTON DES LUMIÈRES
2	2	89700	BAGLYGTE MINIPPOINT - LED	RÜCKLICHT	MINIPPOINT BACKLIGHTS W/OOUT LICENSE PLATE LIGHT	PHARE ARRIÈRE
3	1	89732	KABELSÆT 2x11M - 7-POL STIK - LED	KABELSATZ	CABLE ASSEMBLY	ENSEMBLE DE CÂBLES
4	9	88146	KABELBØJLER 5 mm	KABELHALTER	CABLE BRACKET	COLLIER DE CÂBLE
5	9	92401	GALOPSKRUE PZD. L/H. 4.8 x 16	TAPTITE	TAPTITE	TAPTITE
6	1	89715	MARKERINGSLYS VENSTRE - LED	LEUCHTE LINKS	MARKING LIGHTS, LEFT	LUMIÈRE DE SIGNALISATION GAUCHE
7	1	89716	MARKERINGSLYS HØJRE - LED	LEUCHTE RECHTS	MARKING LIGHTS, RIGHT	LUMIÈRE DE SIGNALISATION GAUCHE
8	4	92253	BOLT M6X55, U/SKAF T GALV. KV. 8.8	SCHRAUBE	SCREW	BOULON
9	4	92027	MØTRIK M6, GALV. KV. 8.8	MUTTER	NUT	ÉCROU
10	4	92050	MØTRIK M12, SELVLÅS, GALV. KV. 8.8	MUTTER SELBSTSCHLIESSEND	SELFLOCKING NUT	ÉCROU DE SÉCURITÉ
11	2	25365	ARM F/LYS T/MINIMAX 1230	ARM	ARM	BRAS
12	4	92299	BOLT 12x70 8.8 GALV.	SCHRAUBE	SCREW	BOULON

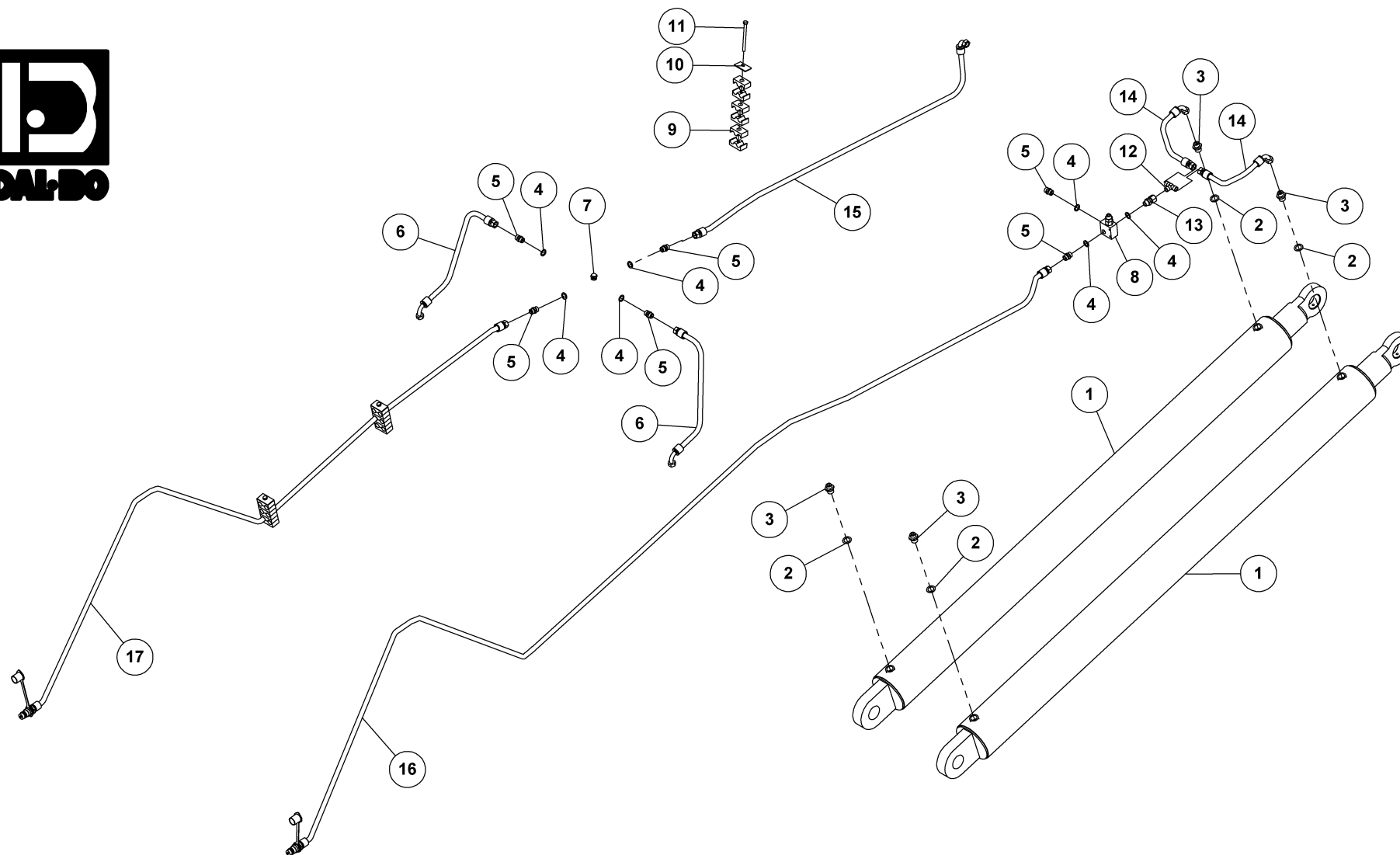

Hydraulik- Vippecylinder POWERROLL 1830

HYDRAULIK
HYDRAULIC

HYDRAULIQUE

25179



HYDRAULIK - VIPPECYLINDER

MINIMAX 1830

25179

HYDRAULIK
HYDRAULIC
HYDRAULIQUE

Pos.	Qty.	Part nr.	Benævnelse	Bezeichnung	Description	Designation
1	2	91881	CYLINDER 130X90-1800	ZYLINDER	RAN	VERRIN
2	4	91029	1/2" BONDED SEALS PAKRING	BONDED SEALS PACKRING	BONDED SEAL WASHER	JOINT BONDED SEALS
3	4	91107	LIGE FORSKRUNING P-GEV 12LR1/2"	VERSCHRAUBUNG	HEXAGON NIPPLE CONNECTOR	RACCORD DE JONCTIONS MÂLES
4	7	91028	3/8" BONDED SEALS PAKRING	BONDED SEALS PACKRING	BONDED SEAL WASHER	JOINT BONDED SEALS
5	6	91003	BRYSTNIPPEL M18 / 3/8" RG GALV.	VERSCHRAUBUNG	HEXAGON NIPPLE CONNECTOR	RACCORD DE JONCTIONS MÂLES
6	2	25563	SLANGE M18V + M18L L=800 MM	SCHLAUCH	HOSE	TUYAU
7	1	91093	SLUTPROP M/PAKNING 3/8"	SCHLUSSSTÖPSEL	END PLUG	BOUCHON DE FERMETURE
8	1	71230	OVERTRYKSVENTIL 50 BAR	ÜBERDRUCKVENTIL	PRESSURE RELIEF VALVE	VALVE DE SUR-PRESSION
9	18	91305	PLASTKLAMME 3/8" DB	PLASTIK KLAMMER	PLASTIC HOSE CLAMP	CROCHET EN PLASTIQUE
10	3	91308	DÆKPLADE T/SLANGEHOLDER	DECKPLATTE FÜR DEN SCHLAUCHHALTER	COVER FOR HOSE CLAMP	DESSUS POUR SUPPORT-TUYAU
11	3	92270	BOLT 8x110 8.8 GALV.	SCHRAUBE	SCREW	BOULON
12	1	91006	T-STYKKE M18X1.5 P-TV 12L	T-STÜCK	T-PIECE	T-PIÈCE
13	1	91113	LIGE FORSKR. P-EGES 12 LR-WD-SV	GERADE VERSCHRAUBUNG	STRAIGHT CONNECTION	JOINT DROIT
14	2	25564	SLANGE M18V + M18L L=600 MM	SCHLAUCH	HOSE	TUYAU
15	1	25565	SLANGE M18V + M18L L=1480 MM	SCHLAUCH	HOSE	TUYAU
16	1	25566	SLANGE HAN + M18L L=6550 MM	SCHLAUCH	HOSE	TUYAU
17	1	25567	SLANGE HAN + M18L L=4800 MM	SCHLAUCH	HOSE	TUYAU

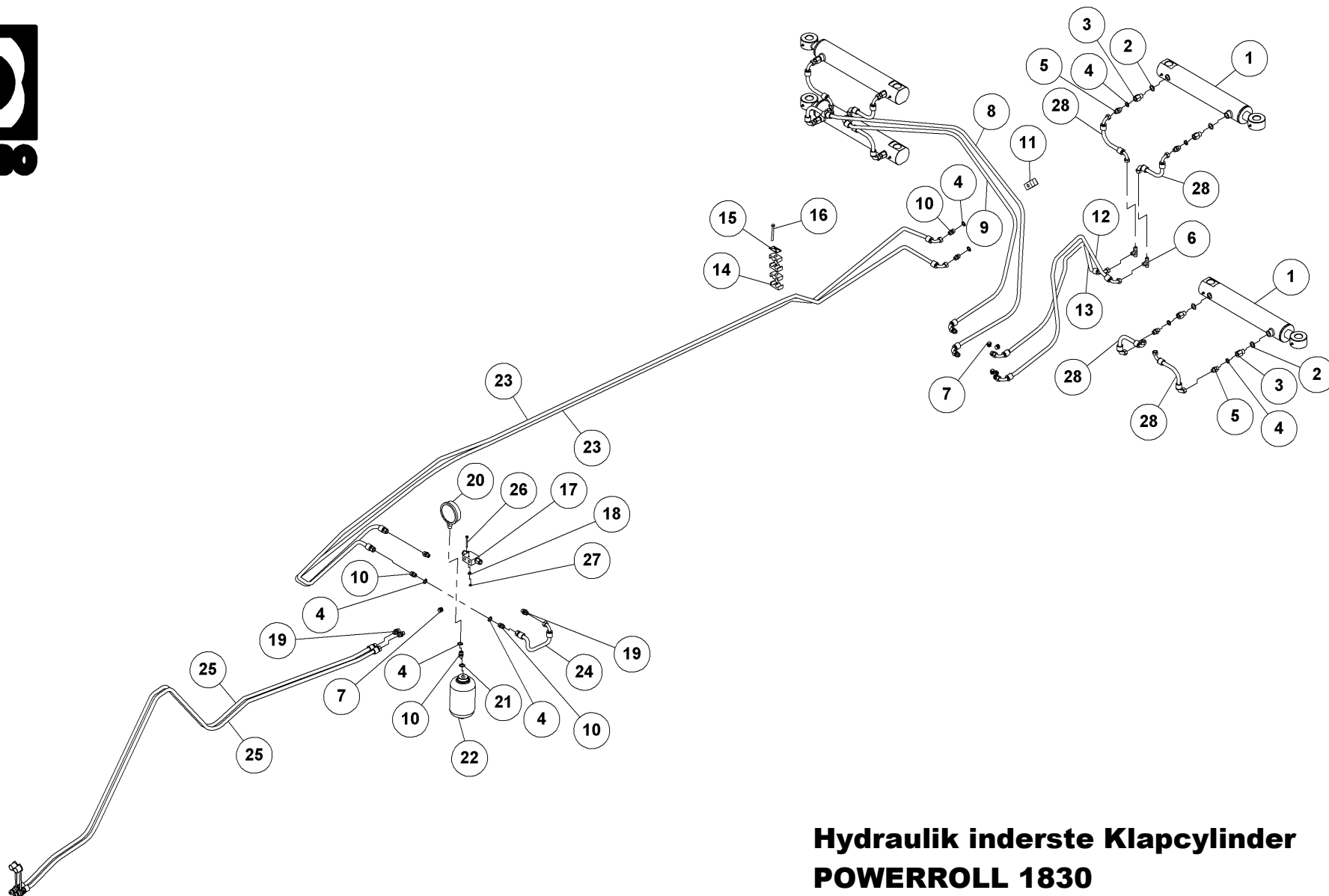

Hydraulik inderste Klapcyliner POWERROLL 1830

HYDRAULIK
HYDRAULIC

HYDRAULIQUE

25180



Hydraulik inderste Klapcylinder 25180

HYDRAULIK
HYDRAULIC

POWERROLL 1830

Pos.	Qty.	Part nr.	Benævneelse	Bezeichnung	Description	Designation
1	4	91805	CYLINDER 80/40x350	ZYLINDER	CYLINDER	VERRIN
2	8	91029	1/2" BONDED SEALS PAKRING	BONDED SEALS PACKRING	BONDED SEAL WASHER	JOINT BONDED SEALS
3	8	91101	NIPPEL-MUFFE 1/2"MALE/3/8"FEMALE	VERSCHRAUBUNG	HEXAGON NIPPLE CONNECTOR	RACCORD DE JONCTIONS MÂLES
4	17	91028	3/8" BONDED SEALS PAKRING	BONDED SEALS PACKRING	BONDED SEAL WASHER	JOINT BONDED SEALS
5	8	91134	DRØVL-BRYSTNIPPEL M18 X 3/8" - Ø1,0	DROSSEL-VERSCHRAUBUNG	THROTTLE, HEXAGON NIPPLE CONNECTOR	RACCORD DE JONCTIONS MÂLES-GRIVE
6	4	91006	T-STYKKE M18X1,5 P-TV 12L	T-STÜCK	T-PIECE	T-PIÈCE
7	5	91093	SLUTPROP M/PAKNING 3/8"	SCHLUSSTÖPSEL	END PLUG	BOUCHON DE FERMETURE
8	1	25569	SLANGE M18V + M18V L=1930 MM	SCHLAUCH	HOSE	TUYAU
9	1	25570	SLANGE M18V + M18V L=1700 MM	SCHLAUCH	HOSE	TUYAU
10	9	91003	BRYSTNIPPEL M18 / 3/8" RG GALV.	VERSCHRAUBUNG	HEXAGON NIPPLE CONNECTOR	RACCORD DE JONCTIONS MÂLES
11	1	91309	PLASTKLAMME. BOLT. DÆKPLADE 3/8" KPL	PLASTIK KLAMMER	PLASTIC HOSE CLAMP	CROCHET EN PLASTIQUE
12	1	25571	SLANGE M18V + M18V L=1530 MM	SCHLAUCH	HOSE	TUYAU
13	1	25572	SLANGE M18V + M18V L=1300 MM	SCHLAUCH	HOSE	TUYAU
14	4	91305	PLASTKLAMME 3/8" DB	PLASTIK KLAMMER	PLASTIC HOSE CLAMP	CROCHET EN PLASTIQUE
15	1	91308	DÆKPLADE T/SLANGEHOLDER	DECKPLATTE FÜR DEN SCHLAUCHHALTER	COVER FOR HOSE CLAMP	DESSUS POUR SUPPORT-TUYAU
16	1	92265	BOLT M8X80, M/SKAFT GALV. KV 8.8	SCHRAUBE	SCREW	BOULON
17	1	27476	PILOTSTYRET KONTRAVENTIL 3/8 - ENKELT	PILOTGESTEUERTES SPERRVENTIL DOPPELT	PILOT-OPERATED CHECK VALVE, DOUBLE	CLAPET DE BLOCAGE PILOTE DOUBLE
18	1	92028	MØTRIK M8, GALV. KV. 8.8	MUTTER	NUT	ÉCROU
19	4	91077	LIGE FORSKRUENING M18 x 3/8"	GERADE VERSCHRAUBUNG	STRAIGHT CONNECTION	JOINT DROIT
20	1	91240	MANOMETER 3/8" RG DALBO	MANOMETER	MANOMETER	MANOMÈTRE
21	1	91026	M18 BONDED SEALS PAKRING	M18 BONDED SEALS PAKRING	BONDED SEAL WASHED	JOINT BONDED SEALS
22	1	91248	AKKUMULATOR 1 L H1000R - 40 BAR	AKKUMULATOR	ACCUMULATOR	ACCUMULATEUR
23	2	25573	SLANGE M18V + M18L L=4200 MM	SCHLAUCH	HOSE	TUYAU
24	1	25574	SLANGE M18V + M18L L=300 MM	SCHLAUCH	HOSE	TUYAU
25	2	25575	SLANGE HAN + M18L L=4400 MM	SCHLAUCH	HOSE	TUYAU
26	1	92253	BOLT M6X55, U/SKAFT GALV. KV. 8.8	SCHRAUBE	SCREW	BOULON
27	1	92027	MØTRIK M6, GALV. KV. 8.8	MUTTER	NUT	ÉCROU
28	8	25568	SLANGE M18V + M18V L=170 MM	SCHLAUCH	HOSE	TUYAU

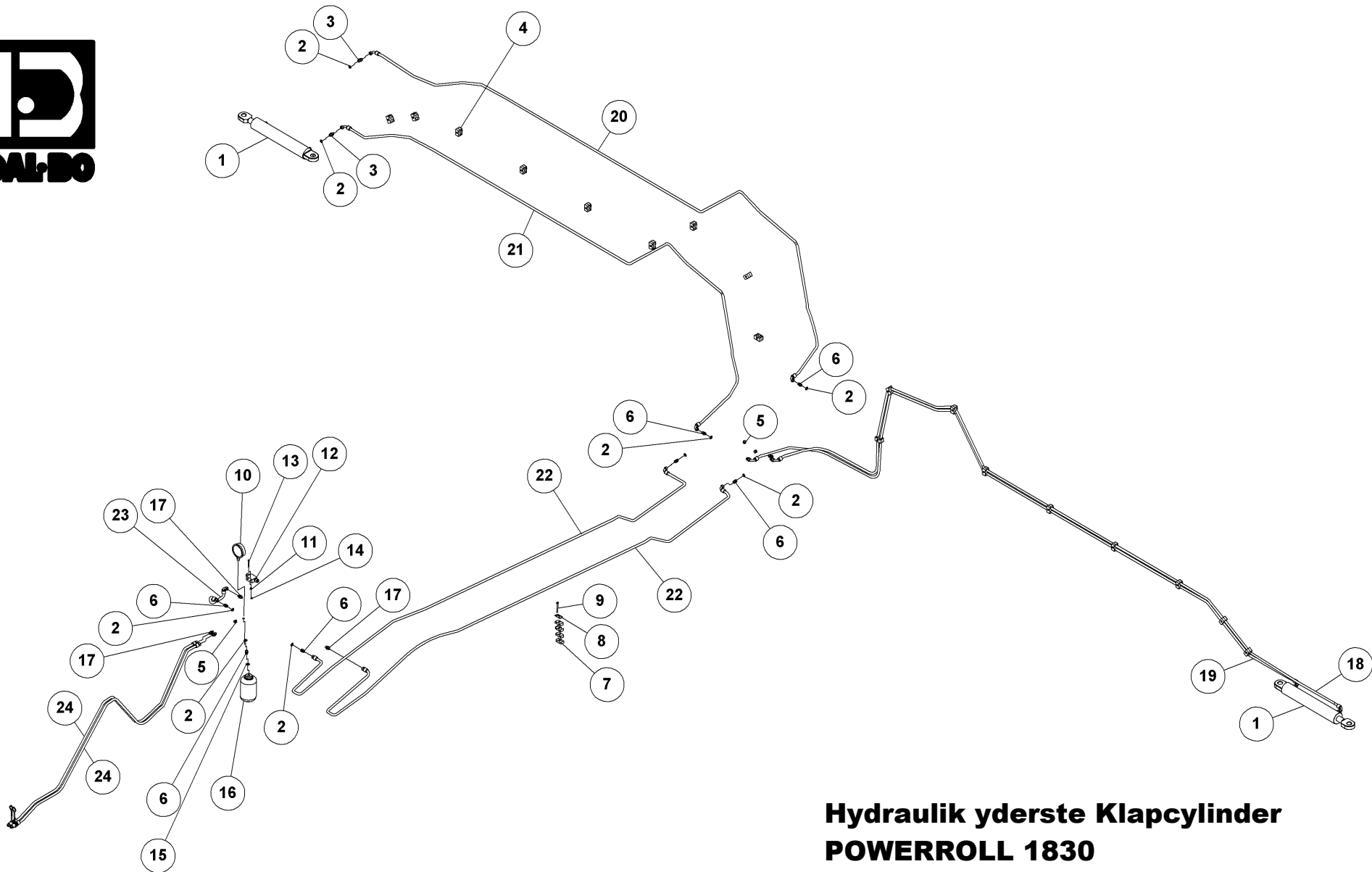

Hydraulik yderste Klapcylinder POWERROLL 1830

HYDRAULIK
HYDRAULIC
HYDRAULIQUE

25181



Hydraulik yderste Klapcylinder 25181

HYDRAULIK
HYDRAULIK

POWERROLL 1830

Pos.	Qty.	Part nr.	Benævnelse	Bezeichnung	Description	Designation
1	2	91825	CYLINDER 80/40X400	ZYLINDER	CYLINDER	CYLINDRE
2	13	91028	3/8" BONDED SEALS PAKRING	BONDED SEALS PAKRING	BONDED SEAL WASHER	JOINT BONDED SEALS
3	4	91134	DRØVL-BRYSTNIPPEL M18 X 3/8" - Ø1,0	DROSSEL-VERSCHRAUBUNG	THROTTLE, HEXAGON NIPPLE CONNECTOR	RACCORD DE JONCTIONS MÂLES-GRIVE
4	18	91309	PLASTKLAMME. BOLT. DÆKPLADE 3/8" KPL	PLASTIK KLAMMER	PLASTIC HOSE CLAMP	CROCHET EN PLASTIQUE
5	5	91093	SLUTPROP M/PAKNING 3/8"	SCHLUSSSTÖPSEL	END PLUG	BOUCHON DE FERMETURE
6	9	91003	BRYSTNIPPEL M18 / 3/8" RG GALV.	VERSCHRAUBUNG	HEXAGON NIPPLE CONNECTOR	RACCORD DE JONCTIONS MÂLES
7	4	91305	PLASTKLAMME 3/8" DB	PLASTIK KLAMMER	PLASTIC HOSE CLAMP	CROCHET EN PLASTIQUE
8	1	91308	DÆKPLADE T/SLANGEHOLDER	DECKPLATTE FÜR DEN SCHLAUCHHALTER	COVER FOR HOSE CLAMP	DESSUS POUR SUPPORT-TUYAU
9	1	92265	BOLT M8X80, M/SKAFT GALV. KV 8.8	SCHRAUBE	SCREW	BOULON
10	1	91240	MANOMETER 3/8" RG DALBO	MANOMETER	MANOMETER	MANOMÈTRE
11	1	92028	MØTRIK M8, GALV. KV. 8.8	MUTTER	NUT	ÉCROU
12	1	27476	PILOTSTYRET KONTRAVENTIL 3/8 - ENKELT	PILOTGESTEUERTES SPERRVENTIL DOPPELT	PILOT-OPERATED CHECK VALVE, DOUBLE	CLAPET DE BLOCAGE PILOTE DOUBLE
13	1	92253	BOLT M6X55, U/SKAFT GALV. KV. 8.8	SCHRAUBE	SCREW	BOULON
14	1	92027	MØTRIK M6, GALV. KV. 8.8	MUTTER	NUT	ÉCROU
15	1	91026	M18 BONDED SEALS PAKRING	M18 BONDED SEALS PAKRING	BONDED SEAL WASHED	JOINT BONDED SEALS
16	1	91248	AKKUMULATOR 1 L H1000R - 40 BAR	AKKUMULATOR	ACCUMULATOR	ACCUMULATEUR
17	4	91077	LIGE FORSKRUENING M18 x 3/8"	GERADE VERSCHRAUBUNG	STRAIGHT CONNECTION	JOINT DROIT
18	1	25576	SLANGE M18V + M18V L=7000 MM	SCHLAUCH	HOSE	TUYAU
19	1	25577	SLANGE M18V + M18V L=6500 MM	SCHLAUCH	HOSE	TUYAU
20	1	25578	SLANGE M18V + M18V L=6600 MM	SCHLAUCH	HOSE	TUYAU
21	1	25579	SLANGE M18V + M18V L=6100 MM	SCHLAUCH	HOSE	TUYAU
22	2	25573	SLANGE M18V + M18L L=4200 MM	SCHLAUCH	HOSE	TUYAU
23	1	25574	SLANGE M18V + M18L L=300 MM	SCHLAUCH	HOSE	TUYAU
24	2	25575	SLANGE HAN + M18L L=4400 MM	SCHLAUCH	HOSE	TUYAU

Hydraulik for spormarkering, hydraulik, hydraulic, hydraulique

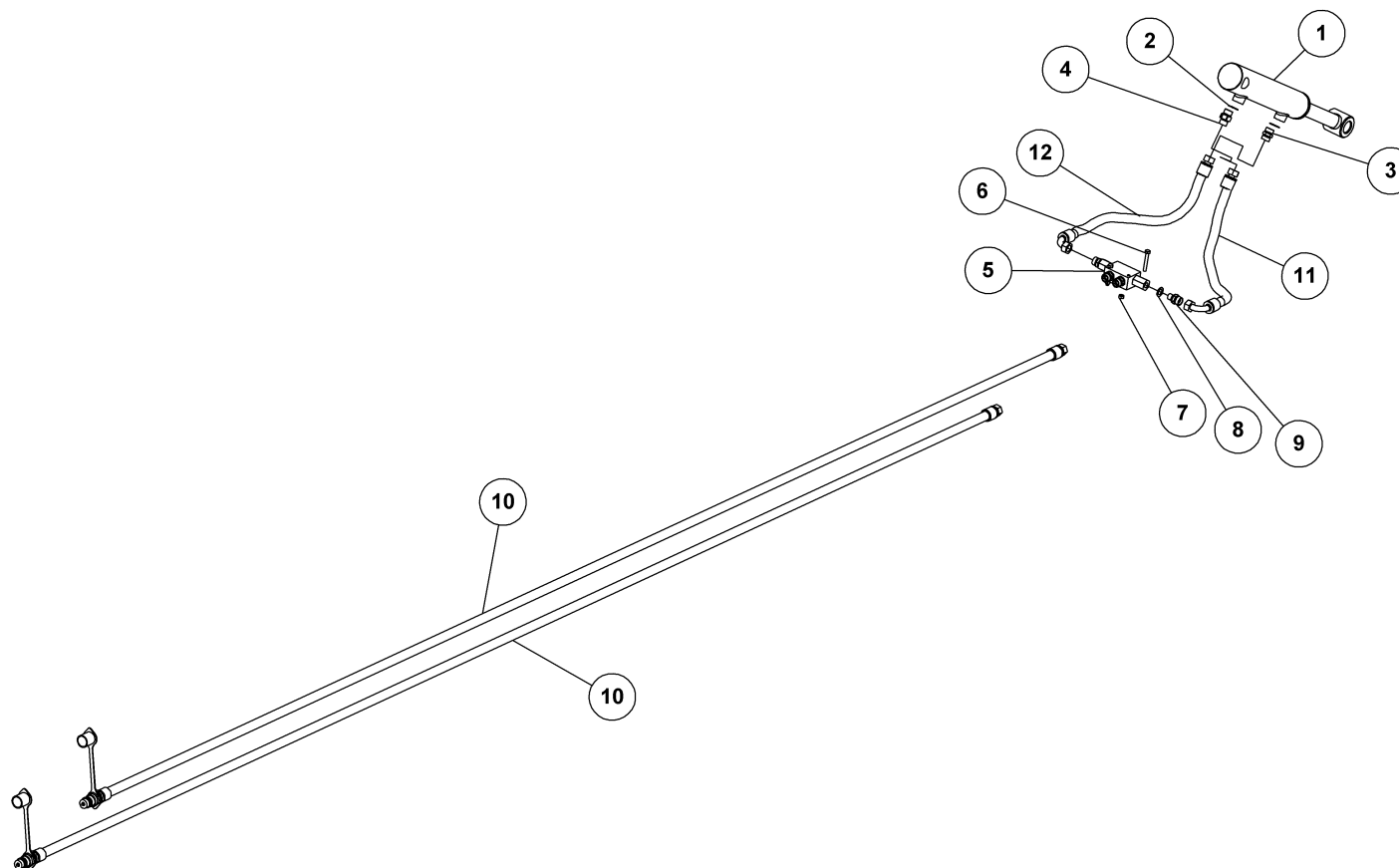

Hydraulik for Spormarkering **POWERROLL 1830**

HYDRAULIK
HYDRAULIC

HYDRAULIQUE

25193



Hydraulik for Spormarkering 25193

HYDRAULIK
HYDRAULIC

POWERROLL 1830

Pos.	Qty.	Part nr.	Benævnelse	Bezeichnung	Description	Designation
1	1	91840	CYLINDER 50/30/150 ø25 L=350	ZYLINDER	CYLINDER	VERRIN
2	2	91028	3/8" BONDED SEALS PAKRING	BONDED SEALS PACKRING	BONDED SEAL WASHER	JOINT BONDED SEALS
3	1	91003	BRYSTNIPPEL M18 / 3/8" RG GALV.	VERSCHRAUBUNG	HEXAGON NIPPLE CONNECTOR	RACCORD DE JONCTIONS MÂLES
4	1	91134	DRØVL-BRYSTNIPPEL M18 X 3/8" - Ø1,0	DROSSEL-VERSCHRAUBUNG	THROTTLE, HEXAGON NIPPLE CONNECTOR	RACCORD DE JONCTIONS MÂLES-GRIVE
5	1	51311	PILOTSTYRET KONTRAVENTIL 1/4 - DOBBELT	PILOTGESTEUERTES SPERRVENTIL DOPPELT	PILOT-OPERATED CHECK VALVE, DOUBLE	CLAPET DE BLOCAGE PILOTE DOUBLE
6	2	92252	BOLT 6x45 8.8 GALV.	SCHRAUBE	SCREW	BOULON
7	2	92027	MØTRIK M6 GALV. kl. 8	MUTTER	NUT	ÉCROU
8	4	91027	1/4" BONDED SEALS PAKRING	BONDED SEALS PACKRING	BONDED SEAL WASHER	JOINT BONDED SEALS
9	4	91045	LIGE FORSKRUNING M18 x 1/4"	GERADE VERSCHRAUBUNG	STRAIGHT CONNECTION	JOINT DROIT
10	2	25583	SLANGE HAN + M18 L L=9850 MM	SCHLAUCH	HOSE	TUYAU
11	1	25584	SLANGE M18 V + M18 L L=330 MM	SCHLAUCH	HOSE	TUYAU
12	1	25585	SLANGE M18 V + M18 L L=430 MM	SCHLAUCH	HOSE	TUYAU

Hydraulik for støtteeen, hydraulik, hydraulic, hydraulique

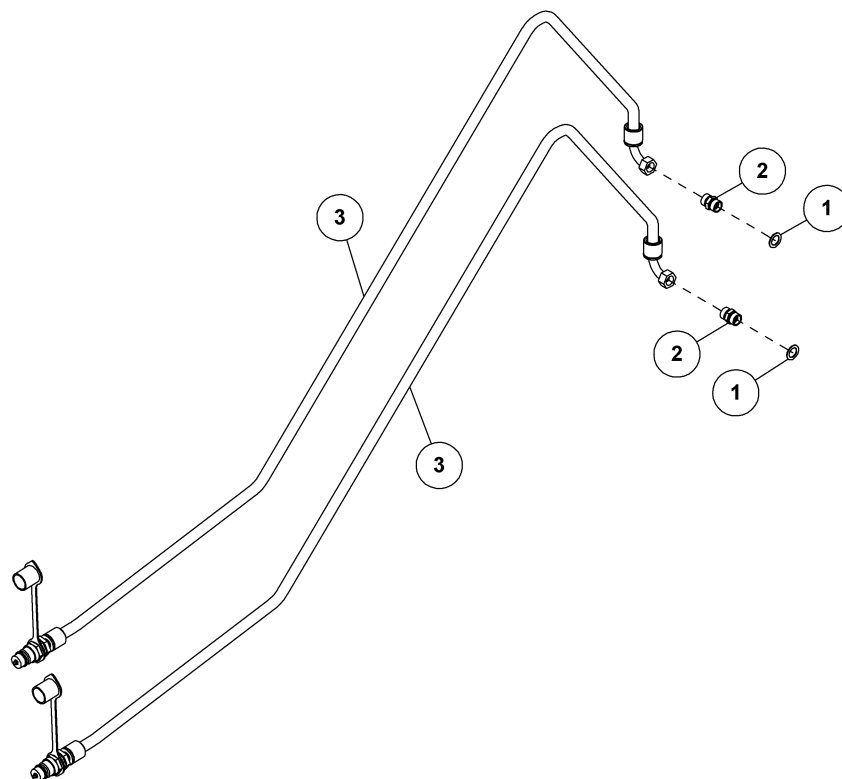

Hydraulik for Støtteeen POWERROLL 1830

HYDRAULIK
HYDRAULIC
HYDRAULIQUE

25183



Hydraulik for Støtteben

HYDRAULIK
HYDRAULIC
HYDRAULIQUE

POWERROLL 1830

25183

Pos.	Qty.	Part nr.	Benævnelse	Bezeichnung	Description	Designation
1	2	91028	3/8" BONDED SEALS PAKRING	BONDED SEALS PACKRING	BONDED SEAL WASHER	JOINT BONDED SEALS
2	2	91003	BRYSTNIPPEL M18 / 3/8" RG GALV.	VERSCHRAUBUNG	HEXAGON NIPPLE CONNECTOR	RACCORD DE JONCTIONS MÂLES
3	2	25580	SLANGE HAN + M18V L=3100 MM	SCHLAUCH	HOSE	TUYAU

Hydraulik til bremses, hydraulik, hydraulic, hydraulique

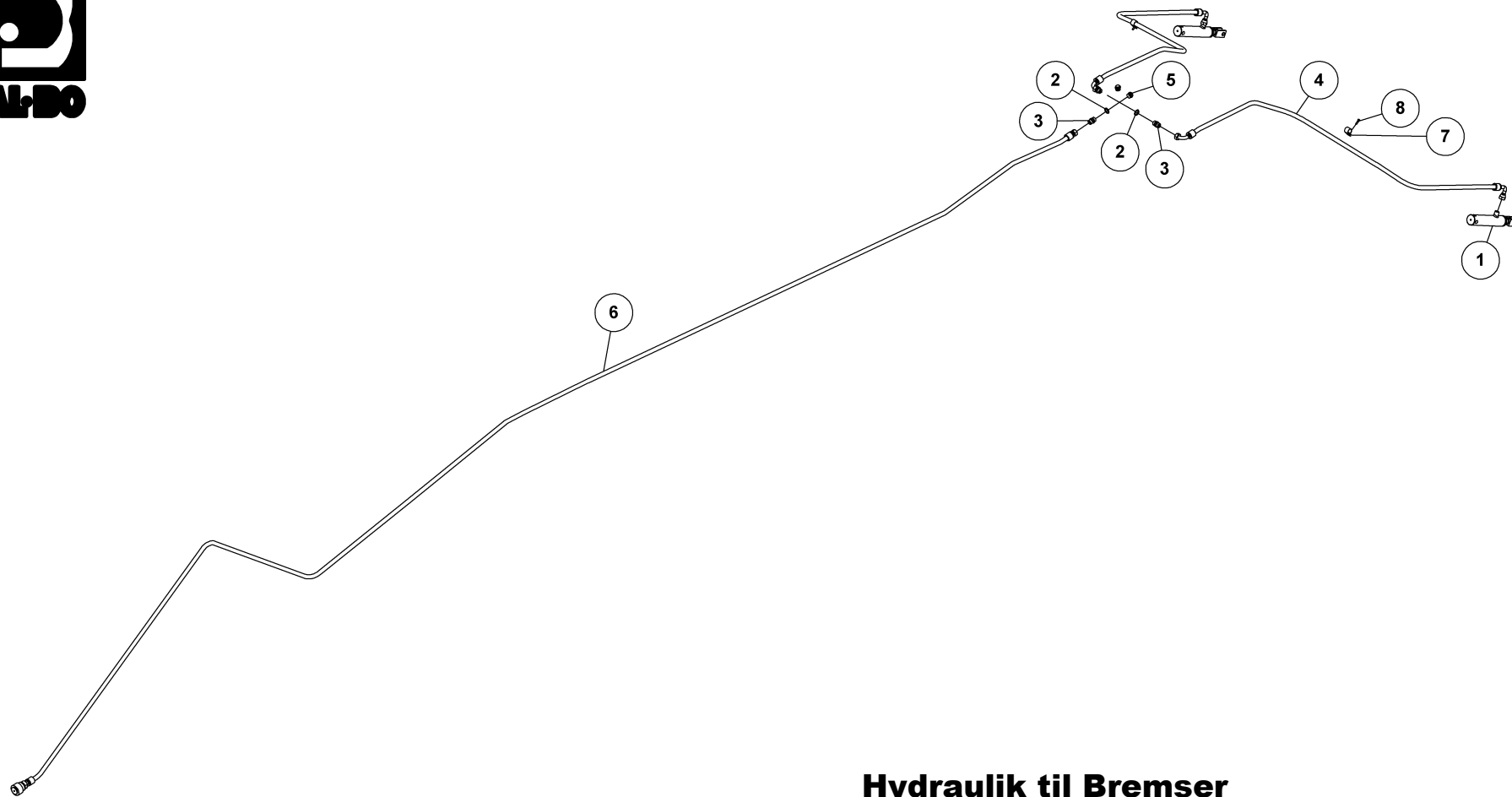

Hydraulik til Bremses POWERROLL 1830

HYDRAULIK
HYDRAULIC
HYDRAULIQUE

25182



Hydraulik til Bremses
25182

HYDRAULIK
HYDRAULIC

POWERROLL 1830

Pos.	Qty.	Part nr.	Benævnelse	Bezeichnung	Description	Designation
1	2	37300	CYLINDER SRBR25 Ø25X75	ZYLINDER	CYLINDER	VERRIN
2	3	91028	3/8" BONDED SEALS PAKRING	BONDED SEALS PACKRING	BONDED SEAL WASHER	JOINT BONDED SEALS
3	3	91003	BRYSTNIPPEL M18 / 3/8" RG GALV.	VERSCHRAUBUNG	HEXAGON NIPPLE CONNECTOR	RACCORD DE JONCTIONS MÂLES
4	2	25581	SLANGE 3/8V + M18V L=1700 MM	SCHLAUCH	HOSE	TUYAU
5	2	91093	SLUTPROP M/PAKNING 3/8"	SCHLUSSSTÖPSEL	END PLUG	BOUCHON DE FERMETURE
6	1	25582	SLANGE BREMSEHUN + M18L L=8300 MM	SCHLAUCH	HOSE	TUYAU
7	2	12256	SLANGEHOLDER GU 1309 / 18 mm.	SCHLAUCHHALTER	HOSE CLAMP	SUPPORT DE TUYAU
8	2	92387	PLADESKRUE PH Ø 4.8X19	SCHRAUBE	PLATE SCREW	VIS DE PLAQUE

Stenkasse 100 L med beslag, Steinkiste, Stone box, Boite a pierres

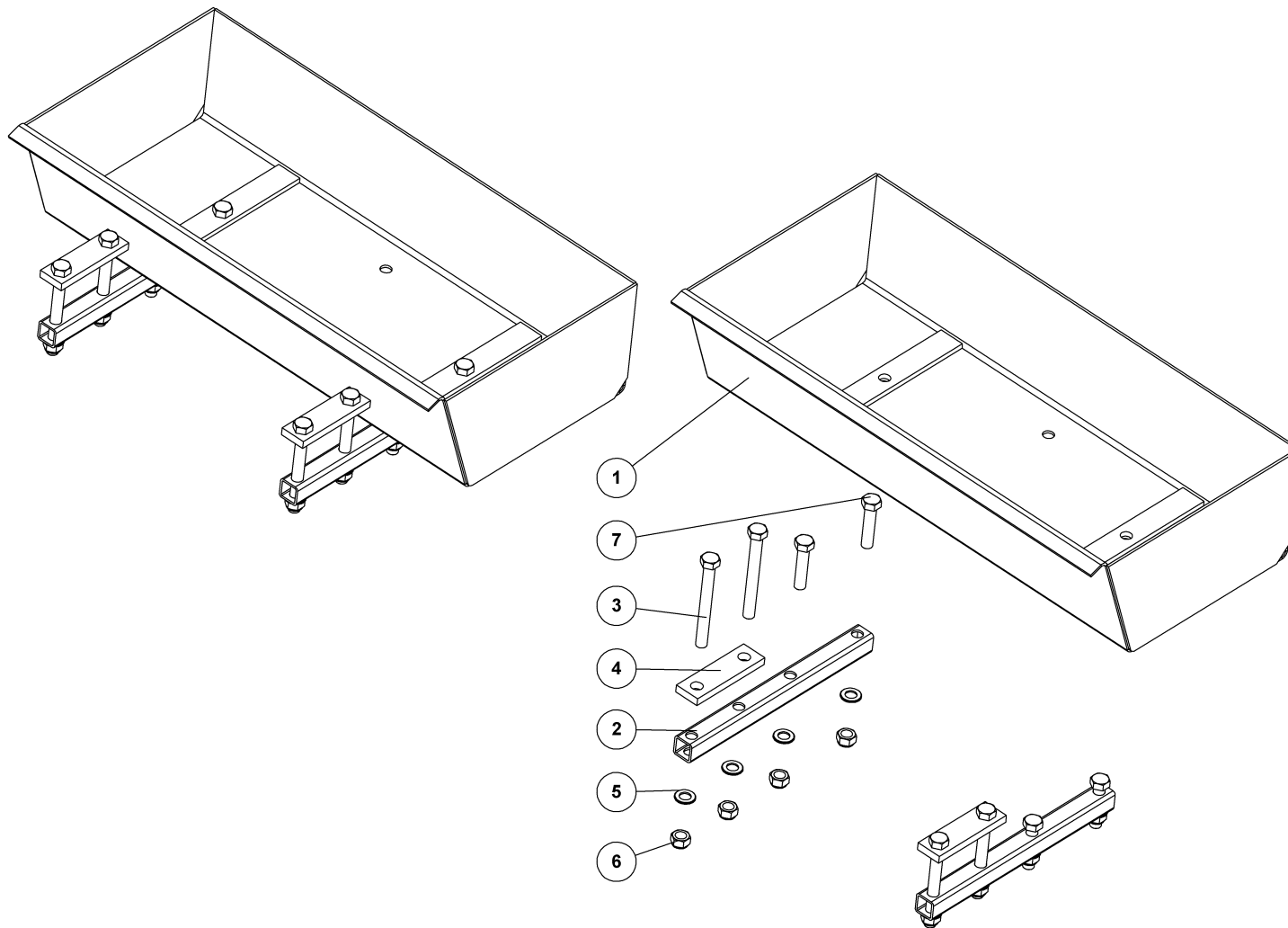

**STENKASSE 2X100L MED BESLAG
POWERROLL 5-DELT**

STEINKISTE
STONE BOX
BOÎTE À PIERRES

23987



STENKASSE 2X100L MED BESLAG

POWERROLL 5-DELT

23987

STEINKISTE
STONE BOX
BOÎTE À PIERRES

Pos.	Qty.	Part nr.	Benævnelse	Bezeichnung	Description	Designation
1	2	23980	STENKASSE 100L	STEINKISTE	STONE BOX	BOÎTE À PIERRES
2	4	24418	BESLAG FOR STENKASSE	BESCHLAG	MOUNTING PLATE	FIXATION
3	8	92339	BOLT 20x180 8.8 GALV.	SCHRAUBE	SCREW	BOULON
4	4	24402	SPÆNDEPLADE Ø22-98-50X15-170	PLATTE	FASTENING PLATE	PLAQUE
5	16	90644	SPÆND. SKIVE Ø37 X Ø21 X 3	UNTERLEGSCHIEBE	SEALING WASHER	RONDELLE DE SERRAGE
6	16	92052	MØTRIK M20, SELVLÅS, GALV. KV. 8.8	MUTTER SELBSTGESICHERT	SELF-LOCKING NUT	ÉCROU DE SÉCURITÉ
7	8	92372	BOLT 20x90 8.8 GALV.	SCHRAUBE	SCREW	BOULON

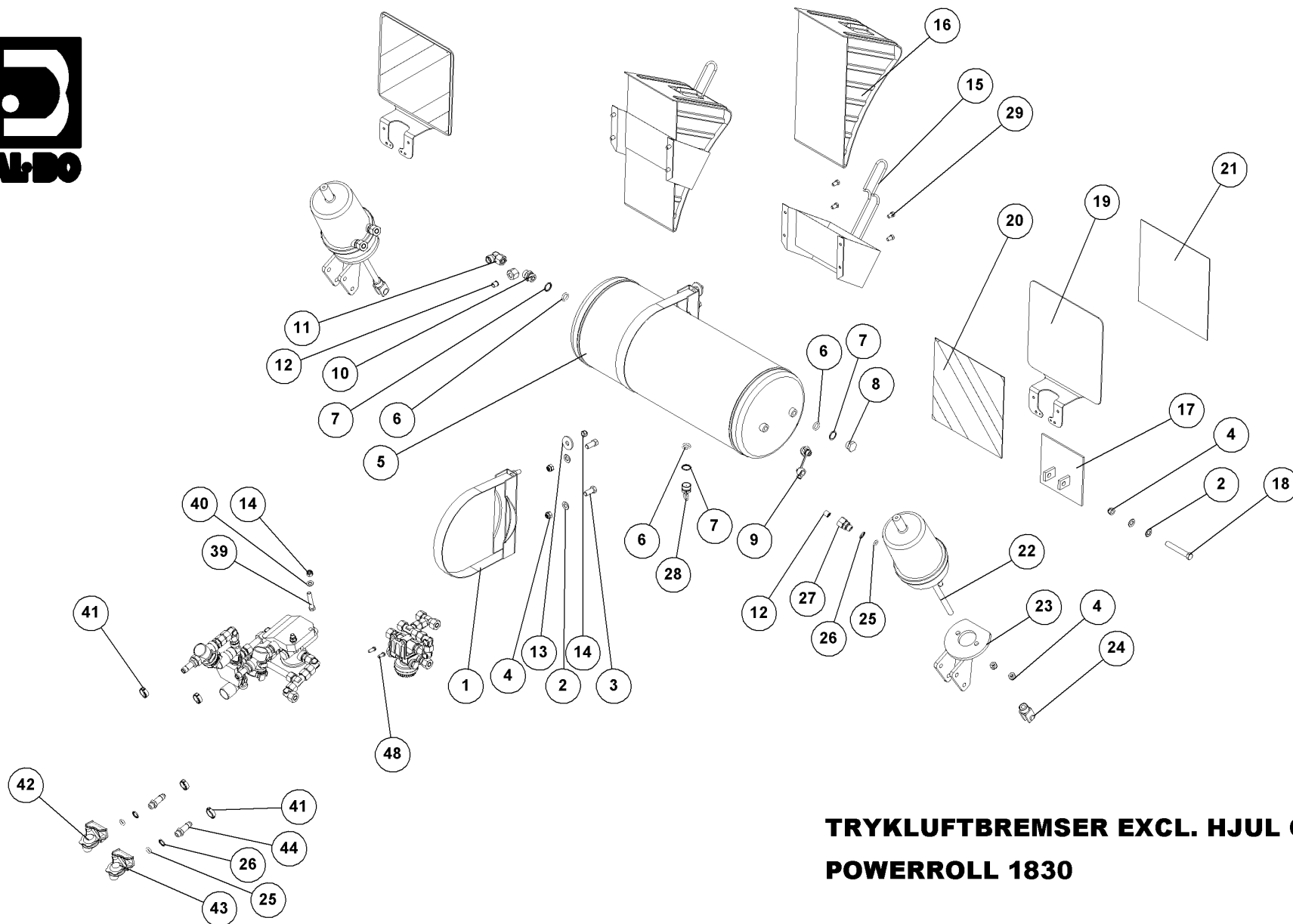

**TRYKLUFTBREMSE EXCL. HJUL OG LYS
POWERROLL 1830**



TRYKLUFTBREMSE EXCL. HJUL OG LYS

POWERROLL 1830

25349

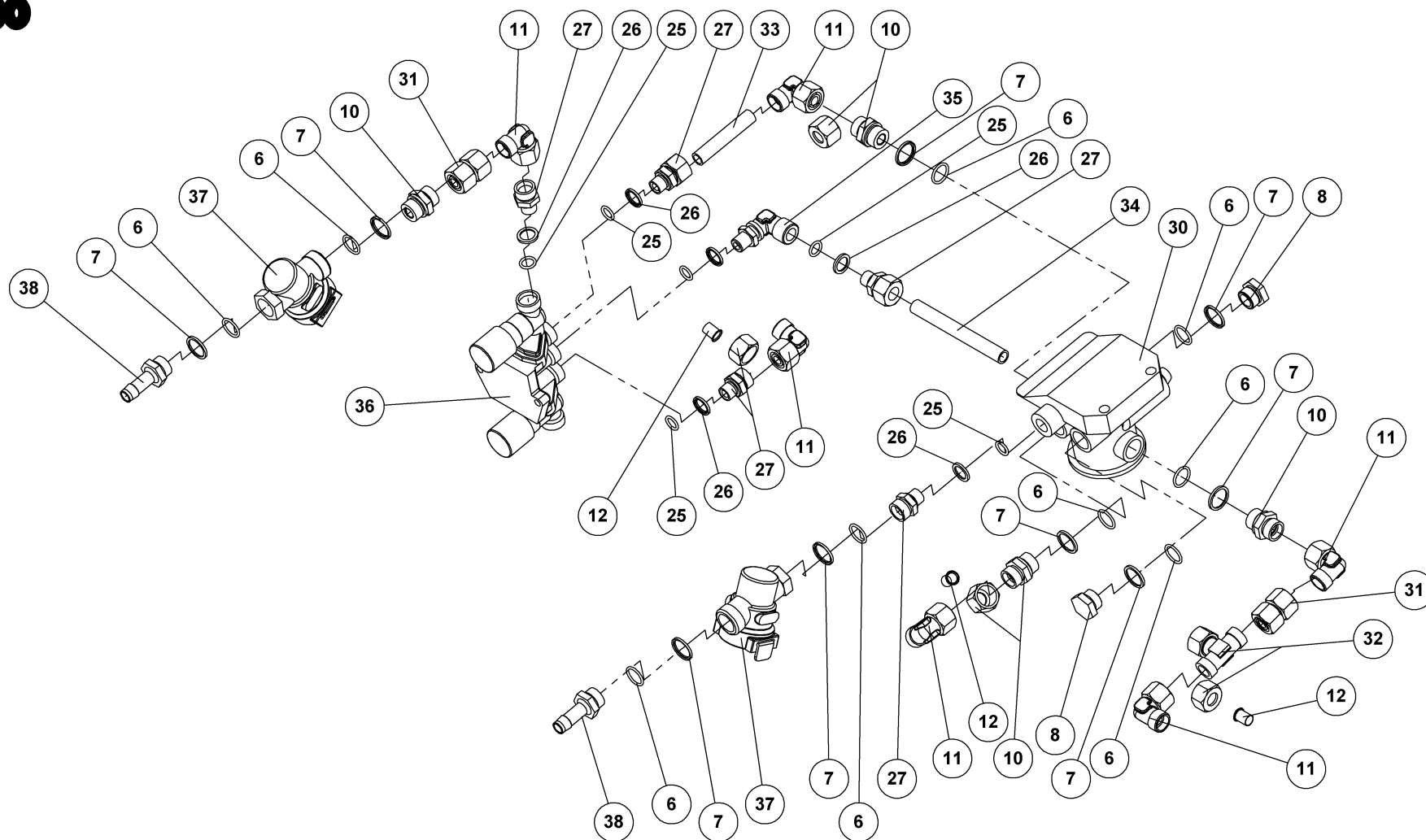



TRYKLUFTBREMSE EXCL. HJUL OG LYS

POWERROLL 1830

25349

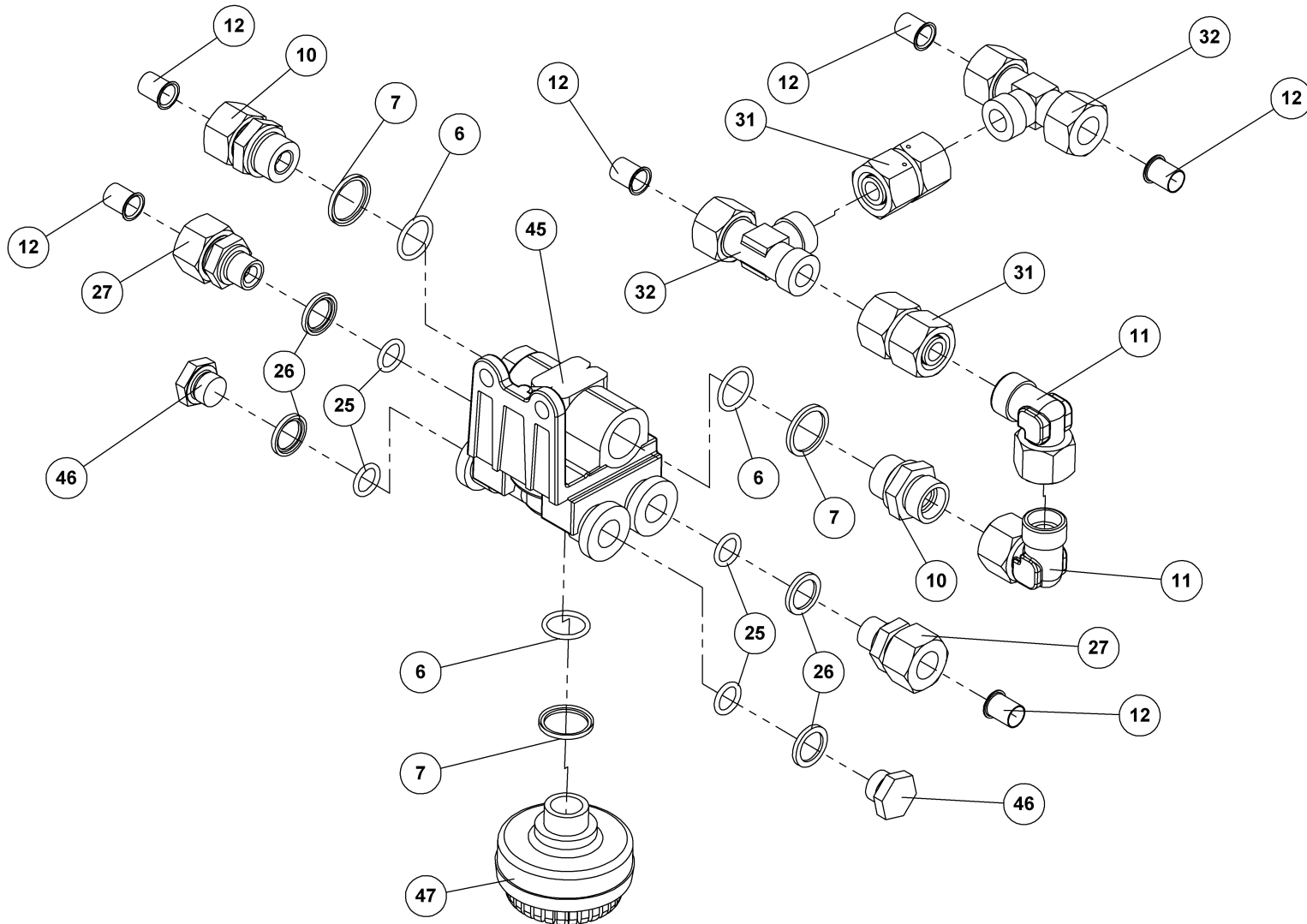



TRYKLUFTBREMSE EXCL. HJUL OG LYS

POWERROLL 1830

25349

Pos.	Qty.	Part nr.	Benævnelse	Bezeichnung	Description	Designation
1	2	88211	LUFTBEHOLDEROPH. F40L - 276 MM	LUFTBEHÄLTERAUFHÄNGUNG	AIR RESERVE TANK MOUNTING BRACKET	SUSPENSION DU RÉSERVOIR À AIR
2	6	90669	SKIVE Ø13-Ø24-2,5	UNTERLEGSCHLEIBE	WASHER	RONDELLE DE SERRAGE
3	4	92295	BOLT 12x30 8.8 GALV. (SÆTBOLT)	SCHRAUBE	SET SCREW	BOULON
4	9	92050	MØTRIK M12, SELVLÅS, GALV. KV. 8.8	MUTTER SELBSTSCHLIESSEND	SELFLOCKING NUT	ÉCROU DE SÉCURITÉ
5	1	88210	BEHOLDER 40 Ltr. Std. 640	BEHÄLTER	RESERVOIR	RÉSERVOIR
6	15	88251	O-RING	O-RING	SEAL	JOINTS
7	15	88252	TÆTNINGSRING	DICHTUNGSRING	SEAL	BAGUE D'ÉTANCHÉITÉ
8	3	88240	GEVINDPROP M. 3MM GENNEMBORING	GEWINDESTÖPSEL	THREADED PLUG	BOUCHON DE FILET
9	1	88219	PRØVETILSLUTNING LIGE, M22X1.5	TESTANSCHLUSS	TEST CONNECTION	JONCTION DE TEST
10	7	88241	15-01/L 15 MA 22x1,5	GERADE VERSCHRAUBUNG	STRAIGHT CONNECTION	JOINT DROIT
11	9	91106	VINKELFORSKRUNING P-EWW 15L-SV	WINKELBEFESTIGUNG	CONNECTOR	JOINT D'ANGLE
12	14	88253	INDSTIKSBØSNING 475 5/8	BUCHSE	BUSHING	DOUILLE
13	2	90652	SP. SKIVE M12 Ø13-Ø40-4 GLV.	UNTERLEGSCHLEIBE	WASHER	RONDELLE DE SERRAGE
14	4	92049	MØTRIK M10, SELVLÅS, GALV. KV. 8.8	MUTTER	SELF-LOCKING NUT	ÉCROU
15	2	88227	HOLDER F. STOPKLODS BREDDE 200 MM	HALTER DER ANSCHLAG	MOUNT FOR STOP BLOCK	SUPPORT DE BLOC D'ARRÊT
16	2	88226	STOPKLODS 200 MM DIN 76051	ANSCHLAG	STOP BLOCK	BLOC D'ARRÊT
17	1	37887	NUMMERPLADEHOLDER	HALTER DER NUMMERPLATE	MOUNT FOR REGISTRATION PLATE	SUPPORT DE PLAQUE
18	1	92547	BOLT 12x90 8.8 GALV	BOLZEN	BOLT	BOULON
19	2	71451	HOLDER FOR WARNTAFELN FOLIE	HALTER	BRACKET	SUPPORT
20	2	89183	WARNFOLIE HØJRE TYP III	REFLEX	REFLEX	REFLET
21	2	89182	WARNFOLIE VENSTRE TYP III	REFLEX	REFLEX	REFLET
22	2	88200	TRISTOP CYLINDER F12/F12	ZYLINDER	RAN	VERRIN
23	2	33575	BESLAG FOR MEMBRAN - KPL.	BESCHLAG	MOUNTING PLATE	FIXATION
24	2	88208	MONTERINGSSÆT KORT GAFFEL	MONTAGESATZ KÜRZE GABEL	MOUNTING SET, SHORT FORK	ENSEMBLE DE MONTAGE FOURCHE
25	16	88249	RU/14x2,5	DICHTUNG	SEAL	JOINTS
26	16	88250	DR/16x21	DICHTUNGSRING	SEAL	BAGUE D'ÉTANCHÉITÉ
27	11	88242	15-01/L 15 MA 16x1,5	GERADE VERSCHRAUBUNG	STRAIGHT CONNECTION	JOINT DROIT
28	1	88212	AFVANDINGSVENTIL	KUGELHAHN	VALVE	VANETTE 3/8"
29	8	92375	BOLT M8X16, U/SKAF T GALV. KV. 8.8	SCHRAUBE	SET SCREW	BOULON
30	1	88215	ANHÆNGER-BREMSEVENTIL	ANHÄNGER BREMSVENTIL	TRAILER AIR-BRAKE VALVE	VALVE DE FREIN-REMORQUE
31	4	91115	LIGEFORSKRUNING P-EWW 15L-SV	GERADE VERSCHRAUBUNG	STRAIGHT CONNECTION	JOINT DROIT
32	3	88247	15-12/L 15	T-SAMMLER	T-CONNECTOR	RAMASSEUR-T
33	1	931410080XXXXXX	HYDRAULIKRØR Ø15X2	HYDR. ROHR	HYDR. TUBE	TUBE HYDR.
34	1	9314100130XXXXXX	HYDRAULIKRØR Ø15X2	HYDR. ROHR	HYDR. TUBE	TUBE HYDR.
35	1	88256	VINKELFORSKRUNING M16X1,5	WINKELBEFESTIGUNG	CONNECTOR	JOINT D'ANGLE
36	1	88195	ANHÆNGER LØSNERVENTIL	VENTIL	VALVE	VALVE DE DESSERREMENT
37	2	88217	LEDNINGSFILTER	LEITUNGSFILTER	WIRE FILTER	FILTRE DE FIL
38	2	88244	ES/B 15-13	ES/B 15-13	NIPPEL, SCHLAUCH	LISSE TUYAU
39	2	92277	BOLT M10X60, M/SKAF T GALV. KV. 8.8	SCHRAUBE	SCREW	BOULON
40	2	90668	SKIVE Ø10,5/Ø20X2 MM	UNTERLEGSCHLEIBE	WASHER	RONDELLE DE SERRAGE
41	4	88235	ØRECLAMPS 20-23 MM	SPANNSTÜCK	PLATE	PIÈCE DE SERRAGE
42	1	88220	SLANGEKOBBLING RØD	SCHLAUCHKUPPLUNG ROT	HOSE COUPLING, RED	JONCTION DE TUYAU ROUGE
43	1	88221	SLANGEKOBBLING GUL	SCHLAUCHKUPPLUNG GELB	HOSE COUPLING, YELLOW	JONCTION DE TUYAU JAUNE
44	2	88243	ES/BM 16x1,5-13	NIPPEL, SCHLAUCH	NIPPLE, HOSE	LISSE TUYAU
45	1	88222	VENTIL 2-VEJS	KUGELHAHN	VALVE	VANETTE 3/8"
46	2	88245	13-01/AM 16x1,5	GEWINDESTÖPSEL	THREADED PLUG	BOUCHON DE FILET
47	1	88236	STØJDEMPER	NOISE BEIN	NOISE ABSORBER	BRUIT ABSORBER
48	2	92247	BOLT M6X20, FLANGE GALV. KV. 8.8	SCHRAUBE	SCREW	BOULON

**TRYKLUFTBREMSE EXCL. HJUL OG LYS****POWERROLL 1830****25349**

Trelleflex kunststofrør 15x1,5mm - Kunststoffrohre - Plastic pipes - Tuyaux en plastique	
Point - Point	PowerRoll 1830
22 - 12	5800mm
2 - 11	5800mm
1,2 - air reservoir	5600mm
12R - 12R	1000mm
11R - 11R	1000mm
12L - 12L	700mm
11L - 11L	700mm
Luftslange 14,5x5mm - Luftschlauch - Airhose - Tuyau d'air	
Rød (red) - 1,1	4150mm
Gul (yellow) - 4	4150mm

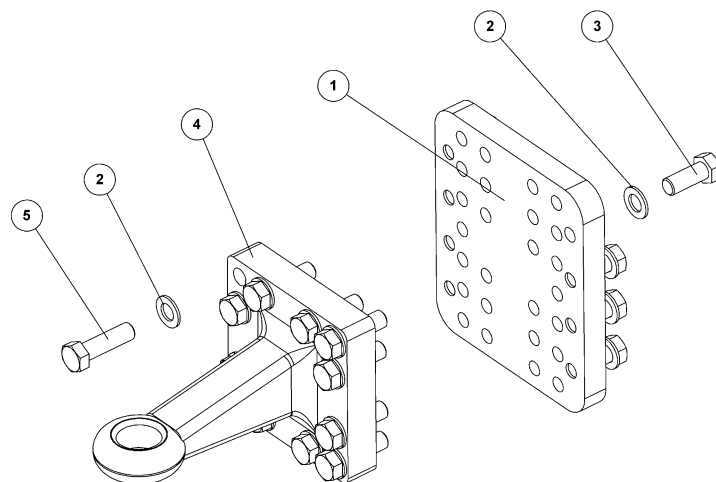

HITCH TRÆK KPL.

POWERROLL 1430-1830, MAXIROLL HD 1030-1230

ZUG
DRAWBAR
ATTELAGE

25174



HITCH TRÆK KPL.

POWERROLL 1430-1830, MAXIROLL HD 1030-1230

25174

ZUG
DRAWBAR
ATTELAGE

Pos.	Qty.	Part nr.	Benævnelse	Bezeichnung	Description	Designation
1	1	63573-1	GEVIND HØJDEPLADE - MALET	BESCHLAG	MOUNTING PLATE	FIXATION
2	20	90671	SKIVE Ø21-Ø37-3	UNTERLEGSCHIEBE	WASHER	RONDELLE DE SERRAGE
3	8	92335	BOLT 20x50 8.8 GALV. (SÆTBOLT)	SCHRAUBE	SET SCREW	BOULON
4	1	25229	SCHARMÜLLER HITCH - 4000 KG	ZUG	DRAWBAR EYE	CROCHET D'ATTELAGE
5	12	92342	BOLT M20X70 MM 8.8 GALV.	SCHRAUBE	SCREW	BOULON

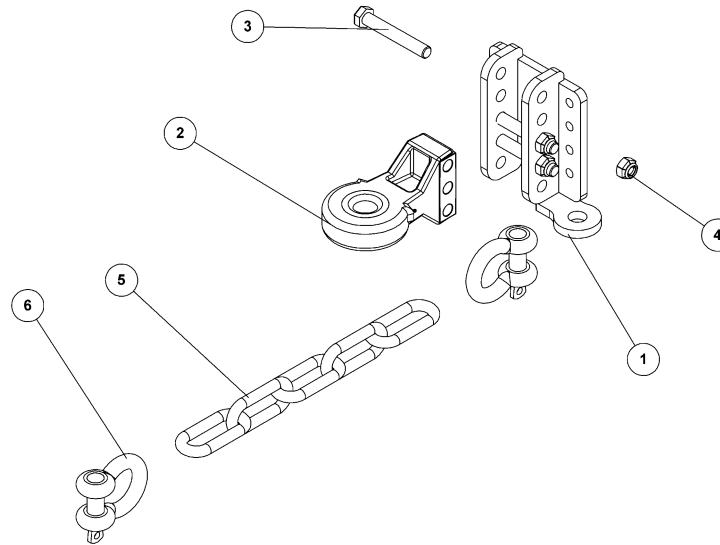

**TRÆK - POWERPULL KAT. 4 - KPL.
POWERROLL 1430-1830, MAXIROLL HD, ROLLOMAXIMUM**

ZUG
DRAWBAR
ATTELAGE

25170



**TRÆK - POWERPULL KAT. 4 - KPL.
POWERROLL 1430-1830, MAXIROLL HD, ROLLOMAXIMUM**

ZUG
DRAWBAR
ATTELAGE

25170

Pos.	Qty.	Part nr.	Benævnelse	Bezeichnung	Description	Designation
1	1	25171	TRÆKADAPTER - POWERPULL TRÆK	ABSTANDS BÜCHSE	SPACER	BAGUE DE DISTANCE
2	1	25200	TRÆK - POWERPULL KAT. 4 - KPL.	ZUG	DRAWBAR	ATTELAGE
3	3	92423	BOLT 27X180 10.9 FZB DIN 931	SCHRAUBE	SCREW	BOULON
4	3	92055	MØTRIK M27. SELVLÅS. GALV. KV. 8.8	MUTTER	NUT	ÉCROU
5	1	25209	KÆDE 12 TONS	KETTE	CHAIN	CHAÎNE
6	2	42581	SJÆKEL H 12,0 T RØD	SCHRAUBENSCHÄKEL	SHACKLE	MANILLE

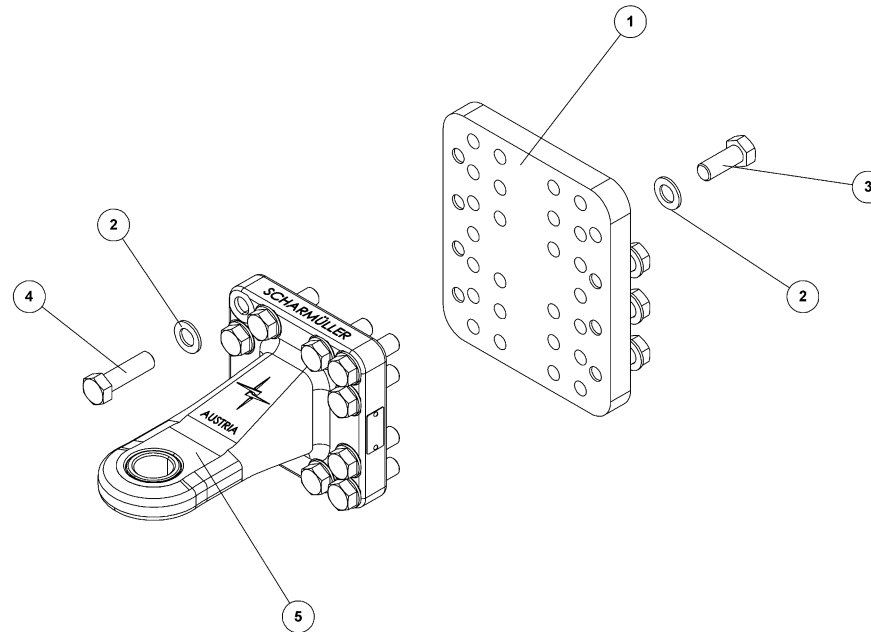

**Ø42 MM TRÆK KPL.
POWERROLL 1430-1830, MAXIROLL HD 1030-1230**

ZUG
DRAWBAR
ATTELAGE

25114



Ø42 MM TRÆK KPL. POWERROLL 1430-1830, MAXIROLL HD 1030-1230

ZUG
DRAWBAR
ATTELAGE

25114

Pos.	Qty.	Part nr.	Benævnelse	Bezeichnung	Description	Designation
1	1	63573-1	GEVIND HØJDEPLADE - MALET	BESCHLAG	MOUNTING PLATE	FIXATION
2	20	90671	SKIVE Ø21-Ø37-3	UNTERLEGSCHIEBE	WASHER	RONDELLE DE SERRAGE
3	8	92335	BOLT 20x50 8.8 GALV. (SÆTBOLT)	SCHRAUBE	SET SCREW	BOULON
4	12	92342	BOLT M20X70 MM 8.8 GALV.	SCHRAUBE	SCREW	BOULON
5	1	25173	SCHARMÜLLER Ø42 MM CAT. 3 - 4000 KG 160 X 160 X 20	ZUG	DRAWBAR	ATTELAGE

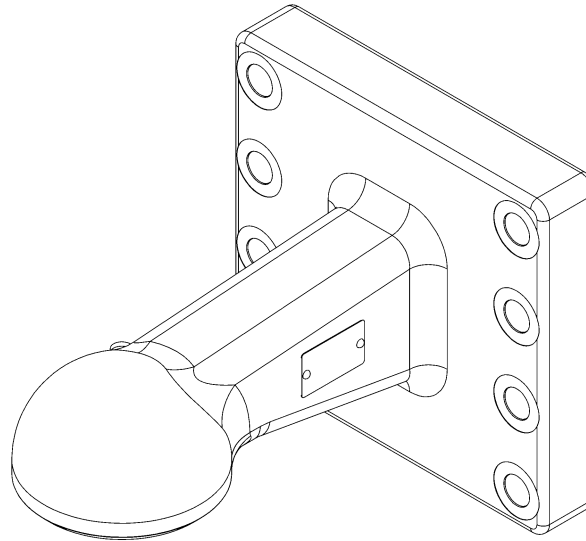

SCHARMÜLLER K80 - 4000 KG
POWERROLL 1430-1830, MAXIROLL HD 1030-1230

25268

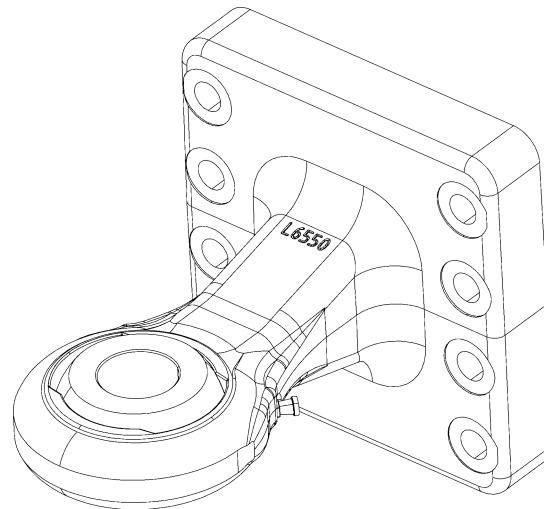

SCHARMÜLLER Ø51 MM CAT. 4 - 4300 KG 205 X 180 X 20
POWERROLL 1430-1830, MAXIROLL HD 1030-1230

25175