



Reservedele Spareparts Ersatzteile Pieces

**3 Bullet Dinco
300/410/470 cm**

Serial no. 0-4

Indholdsfortegnelse,

Table of Contents, Inhaltsverzeichnis, Table des matières

RESERVEDELSLISTENS OPBYGNING, THE CONSTRUCTION OF THE SPAREPARTSLIST,	3
3 BULLET DINCO 300	4
3 BULLET DINCO 410	5
3 BULLET DINCO 470 HYDR.	6
<i>Stilk dobbelt model 2005, Stiel doppelt, Double shank, Tige double</i>	8
<i>Stilk enkel model 2005, single shank, Stiel einfach, tige simple</i>	10
<i>Nav t/skive kpl. Ø35, nabe, hub, moyeu</i>	12
<i>T-rings efterløber 300, roller, nachläufer, train</i>	14
<i>T-ringsaksel 300, T-ring shaft, T-ring achse, arbre d'anneau-T</i>	16
<i>T-rings efterløber 400x60, roller, nachläufer, train</i>	18
<i>T-rings efterløber 300x60, roller, nachläufer, train</i>	19
<i>T-ringsaksel 400x60, T-ring shaft, T-ring achse, arbre d'anneau-T</i>	20
<i>T-ringsaksel 300x60, T-ring shaft, T-ring achse, arbre d'anneau-T</i>	22
<i>Rørpakkervalse, cage roller, rohrtabwalze, rouleau a tube</i>	24
EKSTRAUDSTYR, OPTIONS	26
<i>F-jerns krymler til T-ringefterløber, flat iron cage roller, f-eisen krümmler, rouleau de nivellement de fer en f</i>	26
<i>F-jerns krymler til T-ringefterløber, flat iron cage roller, f-eisen krümmler, rouleau de nivellement de fer en f</i>	28
HYDRAULIK	30
<i>Tand med NSH, tooth cpl, zinken kompl. Hydraulisch, dent cpl hydraulique</i>	30
NSH 300.....	32

Reservedelslistens opbygning, the construction of the sparepartslist,

<p>Reservedelstegningerne tager udgangspunkt i en 3 meter Dinco. Ved de øvrige modeller er der udarbejdet en ekstra reservedelsliste hvor i forskellene som hoveddrummer mm. fremgår</p>	<p>The spare parts drawings have there point of origin in a 3 m Dinco. For the other models there is made an extra spare parts list, where the differences is shown.</p>	<p>Die Ersatzteilzeichnungen sind ursprünglich von der 3 m Dinco. Für die anderen Typen gibt es eine separate Ersatzteilliste, die Unterschiede aufzeigt.</p>	<p>Les dessins des pièces détachées sont basés sur un Dinco 3 m. Pour les autres modèles une liste supplémentaire de pièces est établie où les différences sont montrées.</p>
<p>For deres sikkerhed samt for funktionsdygtigheden af deres maskine, bør der kun anvendes originale Dal-bo reservedele til deres maskine</p> <p>Når de bestiller reservedele bør de altid informere om:</p> <ul style="list-style-type: none"> • Reservedelsnummer • Maskinens typenummer • Antal styk af reservedelen 	<p>For your safety and for the functions of the mashing, you should only use original spare parts for m Dalbo.</p> <p>When you order spare parts, you should always inform about:</p> <ul style="list-style-type: none"> • Spare part number • The mashing type number • Amount of spare parts pieces 	<p>Zu Ihrer Sicherheit und zur einwandfreien Funktion ihres Gerätes sollten sie unbedingt nur original DAL-BO Ersatzteile verwenden.</p> <p>Wenn sie Ersatzteile bestellen bitte folgendes beachten:</p> <ul style="list-style-type: none"> • Ersatzteil-Nummer • Geräte-Nummer und -typ • Anzahl der Ersatzteile 	<p>Pour votre sécurité et pour les fonctions du matériel, vous devez utiliser uniquement des pièces détachées d'origine DALBO.</p> <p>Lorsque vous commandez vos pièces détachées, vous devez toujours nous indiquer :</p> <ul style="list-style-type: none"> • Le numéro de la pièce • Le type de la machine • La quantité des pièces détachées.

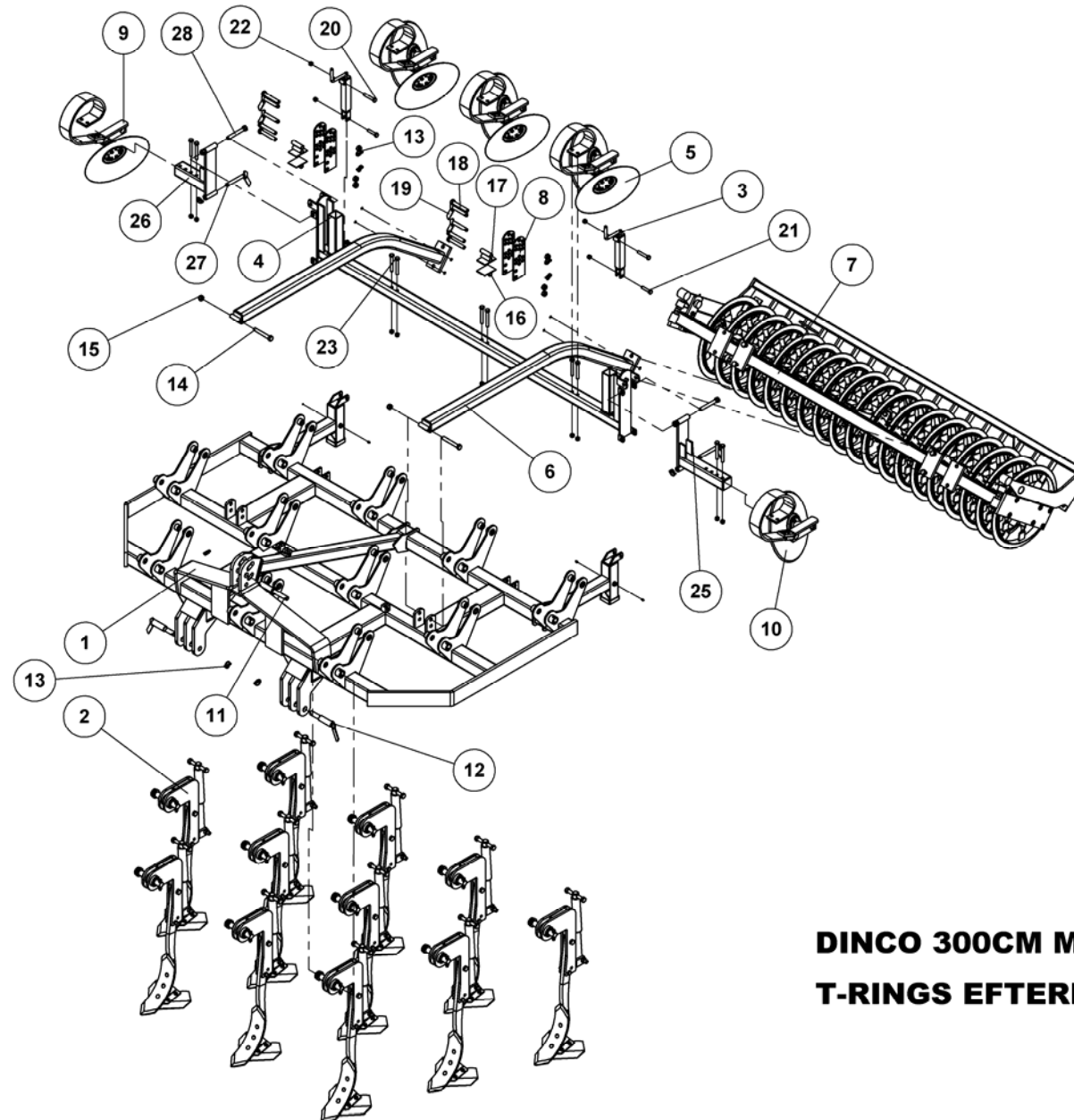

**DINCO 300CM MODEL 3 BULLET
T-RINGS EFTERLØBER**

77142



DINCO 300CM MODEL 3 BULLET

T-RINGS EFTERLØBER

77142

Pos.	Qty.	Part nr.	Benævnelse	Bezeichnung	Description	Designation
1	1	77600	HOVEDDRAMME 3-BULLET 300	HAUPTRAHMEN	MAIN FRAME	CHASSIS
2	11	76268	TAND KPL. M. HYDR.	ZINKEN	TINE	DENT
3	2	21465	SPINDEL SHF 6-01	SPINDEL	SPINDLE	FUSEAU
4	1	77610	TVÆRRØR FOR TALLERKENER KPL. - 300	ROHR	TUBE	TUBE
5	3	77639	STILK DOBBELT MODEL 2005	STIEL DOBBELT	DOUBLE SHANK	TIGE DOUBLE
6	2	77607	ARM FOR EFTERLØBER KPL. - 3 BULLET	ARM FÜR DEN NACHLÄUFER	ARM FOR TOWED ROLLER	BRAS POUR TRAÎNE
7	1	76063	300 CM T-RINGS EFTERLØBER	T-RING WALZE	T-RING ROLLER	ROULEAU A T
8	4	75404	JUSTERPLADE KRYMLER, NY	JUSTIER PLATTE	ADJUSTING PLATE	PLAQUE AJUSTER
9	1	77640	STILK ENKELT, HØJRE 2005	STIEL EINFACH RECHTS	SINGLE SHANK, RIGHT	TIGE SIMPLE DROITE
10	1	77641	STILK ENKELT, VENSTRE 2005	STIEL EINFACH LINKS	SINGLE SHANK, LEFT	TIGE SIMPLE GAUCHE
11	1	90454	NAGLE U Ø25-32X105 KAT. II-III	BOLZEN	PIN	AXE
12	2	76454	NAGLE H Ø28/36,6X178(193)	BOLZEN	PIN	AXE
13	9	90680	RINGSPLIT Ø 8X40 FLAD	RINGSPLINT	LINCH PIN	GOUPILLE
14	2	92340	BOLT 20x140 8.8 GALV.	SCHRAUBE	SCREW	BOULON
15	10	92052	MØTRIK M 20 SELVLÅS. GALV. 8	MUTTER SELBSTGESICHERT	SELF-LOCKING NUT	ÉCROU DE SÉCURITÉ
16	4	76386	STØTTE FOR ARM	STÜTZE FÜR ARM	SUPPORT FOR ARM	BEQUILLE POUR BRAS
17	2	75406	AFSTANDSRØR TIL JUSTERPLADE	ABSTANDSSTÜCK	SPACER	ENTRETOISE
18	6	92341	BOLT 20x130 8.8 GALV.	SCHRAUBE	SCREW	BOULON
19	4	75505	NAGLE H Ø20X110(125)	BOLZEN	PIN	AXE
20	2	92321	BOLT 16x90 8.8 GALV.	SCHRAUBE	SCREW	BOULON
21	2	92319	BOLT 16x70 8.8 GALV.	SCHRAUBE	SCREW	BOULON
22	14	92051	MØTRIK M16 SELVLÅS. GLV. 8	MUTTER	SELF-LOCKING NUT	ÉCROU
23	10	92324	BOLT 16X120 8.8 GALV.	SCHRAUBE	SCREW	BOULON
24	3	90721	SMØRENIPPEL M8x1	SCHMIERNIPPEL	GREASE NIPPLE	GRAISSEUR
25	1	77677	TVÆRRØR FOR TALLERKEN KPL. 300 HØJRE	ROHR	TUBE	TUBE
26	1	77675	TVÆRRØR FOR TALLERKEN KPL. 300 HØJRE	ROHR	TUBE	TUBE
27	2	75503	NAGLE H Ø20X145(160)	BOLZEN	PIN	AXE
28	2	92338	BOLT 20x150 8.8 GALV.	SCHRAUBE	SCREW	BOULON

3 Bullet Dinco 410

DINCO 410CM MODEL 3 BULLET

77144

Pos.	Qty.	Part nr.	Benævnelse	Bezeichnung	Description	Designation
1	1	77600	HOVEDDRAMME 3-BULLET 300	HAUPTRAHMEN	MAIN FRAME	CHASSIS
2	15	76268	TAND KPL.	ZINKEN	TINE	DENT
5	4	77639	STILK DOBBELT MODEL 2005	STIEL DOBBELT	DOUBLE SHANK	TIGE DOUBLE
6	4	77607	ARM FOR EFTERLØBER KPL.	ARM FÜR DEN NACHLÄUFER	ARM FOR TOWED ROLLER	BRAS POUR TRAÎNE
7	1	80424	400 CM T-RINGS EFTERLØBER	T-RING WALZE	T-RING ROLLER	ROULEAU A T
10	2	77641	STILK ENKELT, VENSTRE 2005	STIEL EINFACH LINKS	SINGLE SHANK, LEFT	TIGE SIMPLE GAUCHE
25	1	77669	TVÆRRØR FOR TALLERKEN KPL.	ROHR	TUBE	TUBE
26	2	77673	TVÆRRØR FOR TALLERKEN KPL.	ROHR	TUBE	TUBE

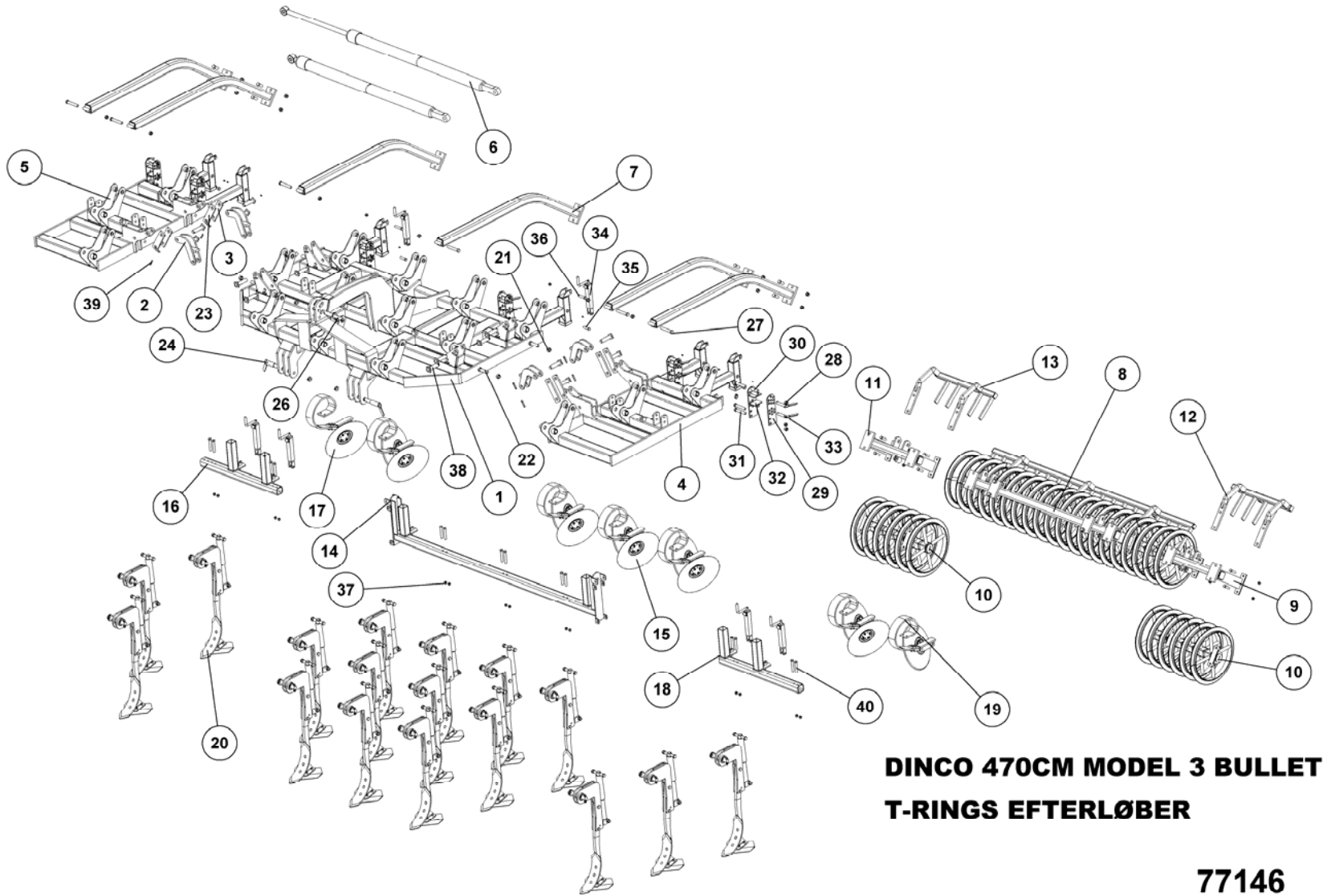



DINCO 470CM MODEL 3 BULLET

T-RINGS EFTERLØBER

77146

Pos.	Qty.	Part nr.	Benævnelse	Bezeichnung	Description	Designation
1	1	77599	HOVEDRAMME 3-BULLET 470	HAUPTTRAHMEN	MAIN FRAME	CHASSIS
2	4	76421	VIPPEARM TIL SIDESEKTION	WIPPARM	ROCKER ARM	BRAS BASCULANTS
3	4	76419	FORBINDELSSESARM M/STOP T/CYLINDER	VERBINDUNGSARME MIT STOP FÜR ZYLINDER	CONNECTING ARM WITH CYLINDER STOP	BRAS DE CONNEXION AVEC ARRÊT DE CYLINDRE
4	1	77647	SIDERAMME 470 3 - BULLET VENSTRE	SEITENRAHMEN LINKS	SIDE FRAME, LEFT	CADRE LATÉRAL GAUCHE
5	1	77648	SIDERAMME 470 3 - BULLET HØJRE	SEITENRAHMEN RECHTS	SIDE FRAME, RIGHT	CADRE LATÉRAL DROITE
6	2	76526	CYLINDER 90/40/800 INDB MÅL 2092	ZYLINDER	RAN	VERRIN
7	6	77607	ARM FOR EFTERLØBER KPL. - 3 BULLET	ARM FÜR DEN NACHLÄUFER	ARM FOR TOWED ROLLER	BRAS POUR TRÂINE
8	1	76059	300 CM EFTERLØBER 20 T-RINGE	NÄCHTLÄUFER	ROLLER T-RING	TRAINF. ANNFAU-T
9	1	77649	EFTERLØBERRAMME 470 VENSTRE	RAHME	FRAME	CADRE
10	2	77655	T-RINGE PÅ AKSEL, SVEJST (6 STK)	T-RING	T-RING	ANNEAU-T
11	1	77652	EFTERLØBERRAMME 470 HØJRE	RAHME	FRAME	CADRE
12	1	77653	AFSKRABERBOM 470 VENSTRE	ABSTREIFER-BALKEN	SCRAPER GANG	BARRE DU SYSTÈME DE RACLAGE
13	1	77654	AFSKRABERBOM 470 HØJRE	ABSTREIFER-BALKEN	SCRAPER GANG	BARRE DU SYSTÈME DE RACLAGE
14	1	77610	TVÆRRØR FOR TALLERKENER KPL. - 300	ROHR	TUBE	TUBE
15	5	77639	STILK DOBBELT MODEL 2005	STIEL DOPPELT	DOUBLE SHANK	TIGE DOUBLE
16	1	77658	TVÆRRØR FOR TALL. KPL. - 470 HØJRE	ROHR	TUBE	TUBE
17	1	77640	STILK ENKELT, HØJRE 2005	STIEL EINFACH RECHTS	SINGLE SHANK, RIGHT	TIGE SIMPLE DROITE
18	1	77659	TVÆRRØR FOR TALL. KPL. - 470 VENSTRE	ROHR	TUBE	TUBE
19	1	77641	STILK ENKELT, VENSTRE 2005	STIEL EINFACH LINKS	SINGLE SHANK, LEFT	TIGE SIMPLE GAUCHE
20	17	76268	TAND KPL. M. HYDR.	ZINKEN	TINE	DENT
21	8	92033	MØTRIK M24 GALV. KI.8	MUTTER	NUT	ÉCROU
22	4	92352	BOLT 24x100 8.8 GALV.	SCHRAUBE	SCREW	BOULON
23	4	76418	FORBINDELSSESARM TIL CYLINDER	VERBINDUNGSARME FÜR ZYLINDER	CONNECTING ARM FOR CYLINDER	BRAS DE CONNEXION POUR CYLINDRE
24	2	76454	NAGLE H Ø28/36,6X178(193)	BOLZEN	PIN	AXE
25	15	90680	RINGSPLIT Ø 8X40 FLAD	RINGSPLINT	LINCH PIN	GOUPILLE
26	1	90454	NAGLE U Ø25-32X105 KAT. II-III	BOLZEN	PIN	AXE
27	6	92340	BOLT 20x140 8.8 GALV.	SCHRAUBE	SCREW	BOULON
28	32	92052	MØTRIK M 20 SELVLÅS. GALV. 8	MUTTER SELBSTGESICHERT	SELF-LOCKING NUT	ÉCROU DE SÉCURITÉ
29	12	75404	JUSTERPLADE KRYMLER, NY	JUSTIER PLATTE	ADJUSTING PLATE	PLAQUE AJUSTER
30	6	75406	AFSTANDSRØR TIL JUSTERPLADE	ABSTANDSSTÜCK	SPACER	ENTRETOISE
31	18	92341	BOLT 20x130 8.8 GALV.	SCHRAUBE	SCREW	BOULON
32	12	76386	STØTTE FOR ARM	STÜTZE FÜR ARM	SUPPORT FOR ARM	BEQUILLE POUR BRAS
33	12	75505	NAGLE H Ø20X110(125)	BOLZEN	PIN	AXE
34	6	21465	SPINDEL SHF 6-01	SPINDEL	SPINDLE	FUSEAU
35	14	92319	BOLT 16x70 8.8 GALV.	SCHRAUBE	SCREW	BOULON
36	6	92321	BOLT 16x90 8.8 GALV.	SCHRAUBE	SCREW	BOULON
37	34	92051	MØTRIK M16 SELVLÅS. GLV.8	MUTTER	SELF-LOCKING NUT	ÉCROU
38	16	76451	NAGLE F Ø30X115(143)	BOLZEN	PIN	AXE
39	16	90677	SPLIT 8X50 MM GALV.	SPLINT	SPLIT PIN	GOUPILLE
40	14	92324	BOLT 16X120 8.8 GALV.	SCHRAUBE	SCREW	BOULON
41	12	90721	SMØRENIPPEL M8x1	SCHMIERNIPPEL	GREASE NIPPLE	GRAISSEUR
42	8	92334	BOLT 20x60 8.8 GALV.	SCHRAUBE	SCREW	BOULON

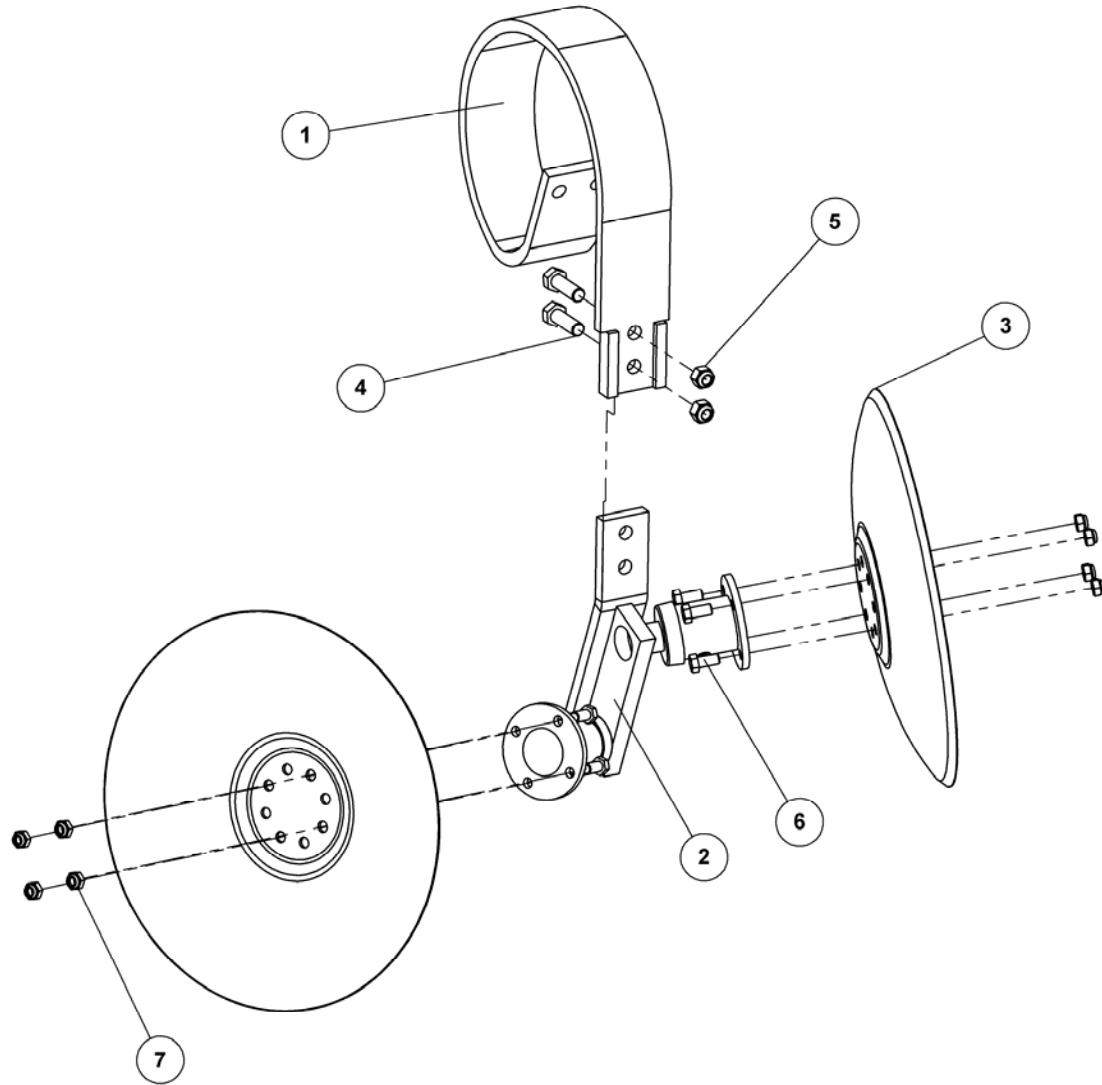

**STILK DOBBELT MODEL 2005
3 BULLET**

STIEL DOPPELT
DOUBLE SHANK
TIGE DOUBLE

77639



STILK DOBBELT MODEL 2005

3 BULLET

77639

STIEL DOPPELT
DOUBLE SHANK
TIGE DOUBLE

Pos.	Qty.	Part nr.	Benævnelse	Bezeichnung	Description	Designation
1	1	77638	SOLBJERG FJEDER 90X13	FEDER	SPRING	RESSORT
2	1	77614	NAVVEN DOBBELT	NABEBEIN	HUB LEG	PIED DE MOYEU
3	2	75261	TALLERKEN Ø460x4 GLAT	SCHIEBE	DISC	RONDELLE
4	2	92317	BOLT 16x50 8 8 GALV. (SÆTBOLT)	SCHRAUBE	SET SCREW	BOULON
5	2	92051	MØTRIK M16 SELVLÅS. GLV.8	MUTTER	SELF-LOCKING NUT	ÉCROU
6	8	92294	BOLT 12x25 8 8 GALV. (SÆTBOLT)	SCHRAUBE	SET SCREW	BOULON
7	8	92050	MØTRIK M12 SELVLÅS. GLV. 8	MUTTER SELBSTSCHLIESSEND	SELFLOCKING NUT	ÉCROU DE SÉCURITÉ

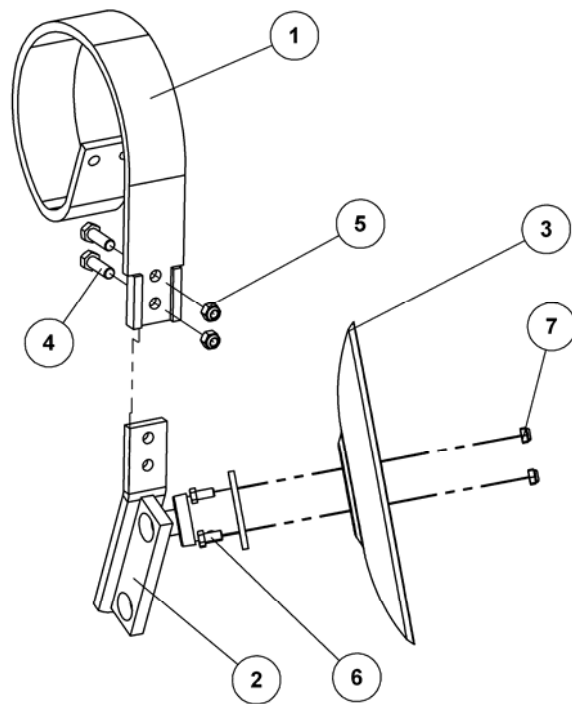

STILK ENKELT, HØJRE 2005
3 BULLET

STIEL EINFACH RECHTS
SINGLE SHANK, RIGHT
TIGE SIMPLE DROITE

77640

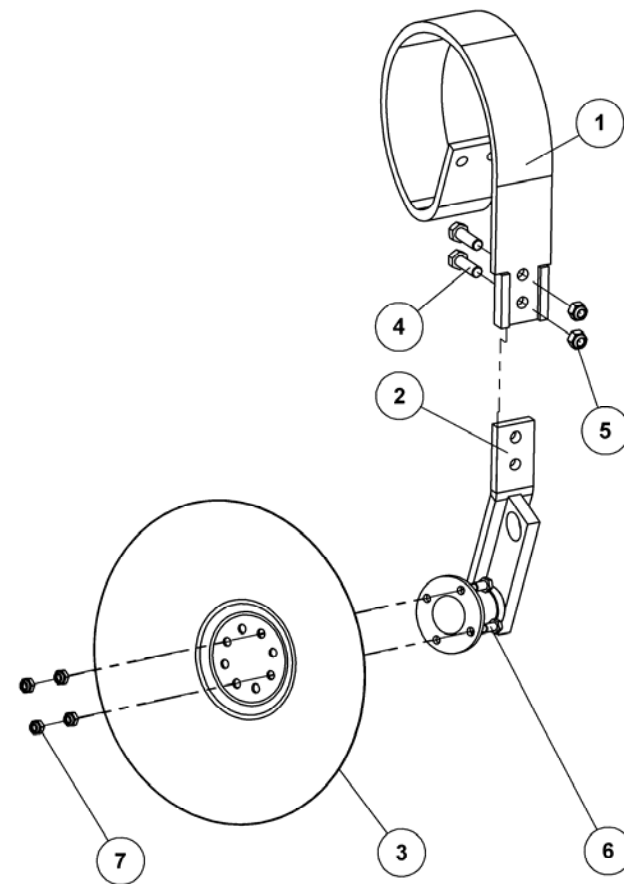

STILK ENKELT, VENSTRE 2005
3 BULLET

STIEL EINFACH LINKS
SINGLE SHANK, LEFT
TIGE SIMPLE GAUCHE

77641



STILK ENKELT, HØJRE 2005

3 BULLET

77640

STIEL EINFACH RECHTS
SINGLE SHANK, RIGHT
TIGE SIMPLE DROITE

Pos.	Qty.	Part nr.	Benævnelse	Bezeichnung	Description	Designation
1	1	77638	SOLBJERG FJEDER 90X13	FEDER	SPRING	RESSORT
2	1	77619	NAVVEN ENKELT HØJRE	NABEBEIN	HUB LEG	PIED DE MOYEU
3	1	75261	TALLERKEN Ø460x4 GLAT	SCHIEBE	DISC	RONDELLE
4	2	92317	BOLT 16x50 8.8 GALV. (SÆTBOLT)	SCHRAUBE	SET SCREW	BOULON
5	2	92051	MØTRIK M16 SELVLÅS. GLV.8	MUTTER	SELF-LOCKING NUT	ÉCROU
6	4	92294	BOLT 12x25 8.8 GALV. (SÆTBOLT)	SCHRAUBE	SET SCREW	BOULON
7	4	92050	MØTRIK M12 SELVLÅS. GLV. 8	MUTTER SELBSTSCHLIESSEND	SELFLOCKING NUT	ÉCROU DE SÉCURITÉ



STILK ENKELT, VENSTRE 2005

3 BULLET

77641

STIEL EINFACH LINKS
SINGLE SHANK, LEFT
TIGE SIMPLE GAUCHE

Pos.	Qty.	Part nr.	Benævnelse	Bezeichnung	Description	Designation
1	1	77638	SOLBJERG FJEDER 90X13	FEDER	SPRING	RESSORT
2	1	77615	NAVVEN ENKELT VENSTRE	NABEBEIN	HUB LEG	PIED DE MOYEU
3	1	75261	TALLERKEN Ø460x4 GLAT	SCHIEBE	DISC	RONDELLE
4	2	92317	BOLT 16x50 8.8 GALV. (SÆTBOLT)	SCHRAUBE	SET SCREW	BOULON
5	2	92051	MØTRIK M16 SELVLÅS. GLV.8	MUTTER	SELF-LOCKING NUT	ÉCROU
6	4	92294	BOLT 12x25 8.8 GALV. (SÆTBOLT)	SCHRAUBE	SET SCREW	BOULON
7	4	92050	MØTRIK M12 SELVLÅS. GLV. 8	MUTTER SELBSTSCHLIESSEND	SELFLOCKING NUT	ÉCROU DE SÉCURITÉ

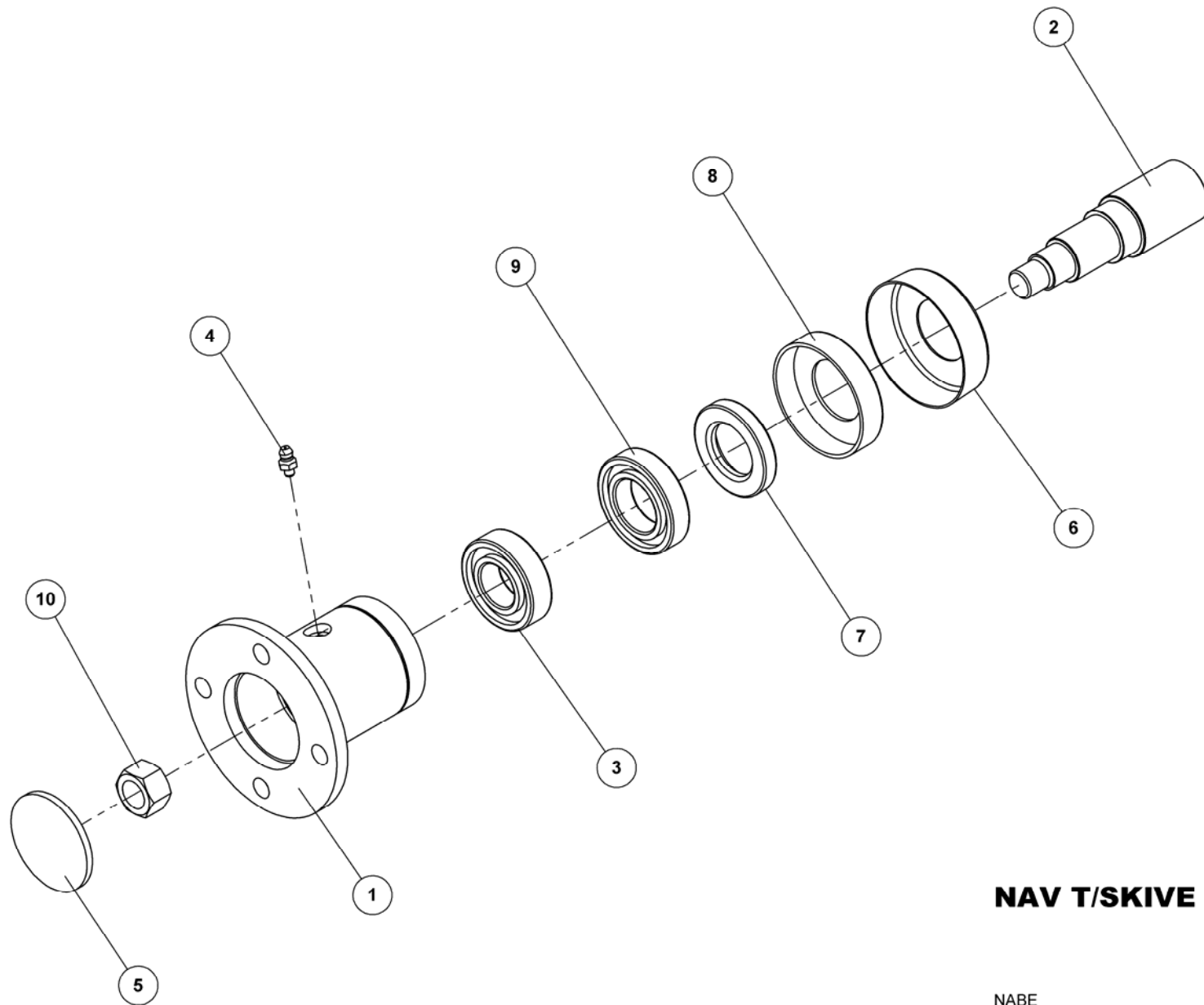

NAV T/SKIVE KPL. Ø35

NABE
HUB
MOYEU DE RONDELLE CPL.

76885



NAV T/SKIVE KPL. Ø35

76885

NABE
HUB
MOYEU DE RONDELLE CPL.

Pos.	Qty.	Part nr.	Benævnelse	Bezeichnung	Description	Designation
1	1	76887	NAVHUS TIL Ø35 AKSEL	NABEGEHAUSE	HUB HOUSING	BOÎTE DE MOYEU
2	1	76888	AKSEL Ø35X121 TIL NAV	ACHSE	SHAFT	ARBRE
3	1	75272	KUGLELEJE 6205	LAGER	BEARING	FIXATION
4	1	75889	SMØRENIPPEL M6X1 K	SCHMIERNIPPEL	GREASE NIPPLE	GRAISSEUR
5	1	75891	GUMMISKIVE T/NAV 55.5x4	GUMMISCHEIBE	RUBBER WASHER FOR HUB	RONDELLE EN CAOUTCHOUC POUR MOYEU
6	1	76886	STØVKAPPE M. Ø35 MM HUL - STÅL	STAUBKAPPE FÜR NABE - STAHL	DUST CAP FOR HUB. STEEL	CACHE-POUSSIÈRE POUR MOYEU - ACIER
7	1	76890	TÆTNINGSRING 55/35/10 T/NAV	DICHTUNGSRING	SEAL	BAGUE D'ÉTANCHÉITÉ
8	1	75892	STØVKAPPE T/NAV PLAST	STAUBKAPPE FÜR NABE - PLASTIK	DUST CAP FOR HUB. PLASTIC	CACHE-POUSSIÈRE POUR MOYEU - PLASTIQUE
9	1	75273	KUGLELEJE 6006	LAGER	BEARING	FIXATION
10	1	92031	MØTRIK M16 GALV. kl.8	MUTTER	NUT	ÉCROU

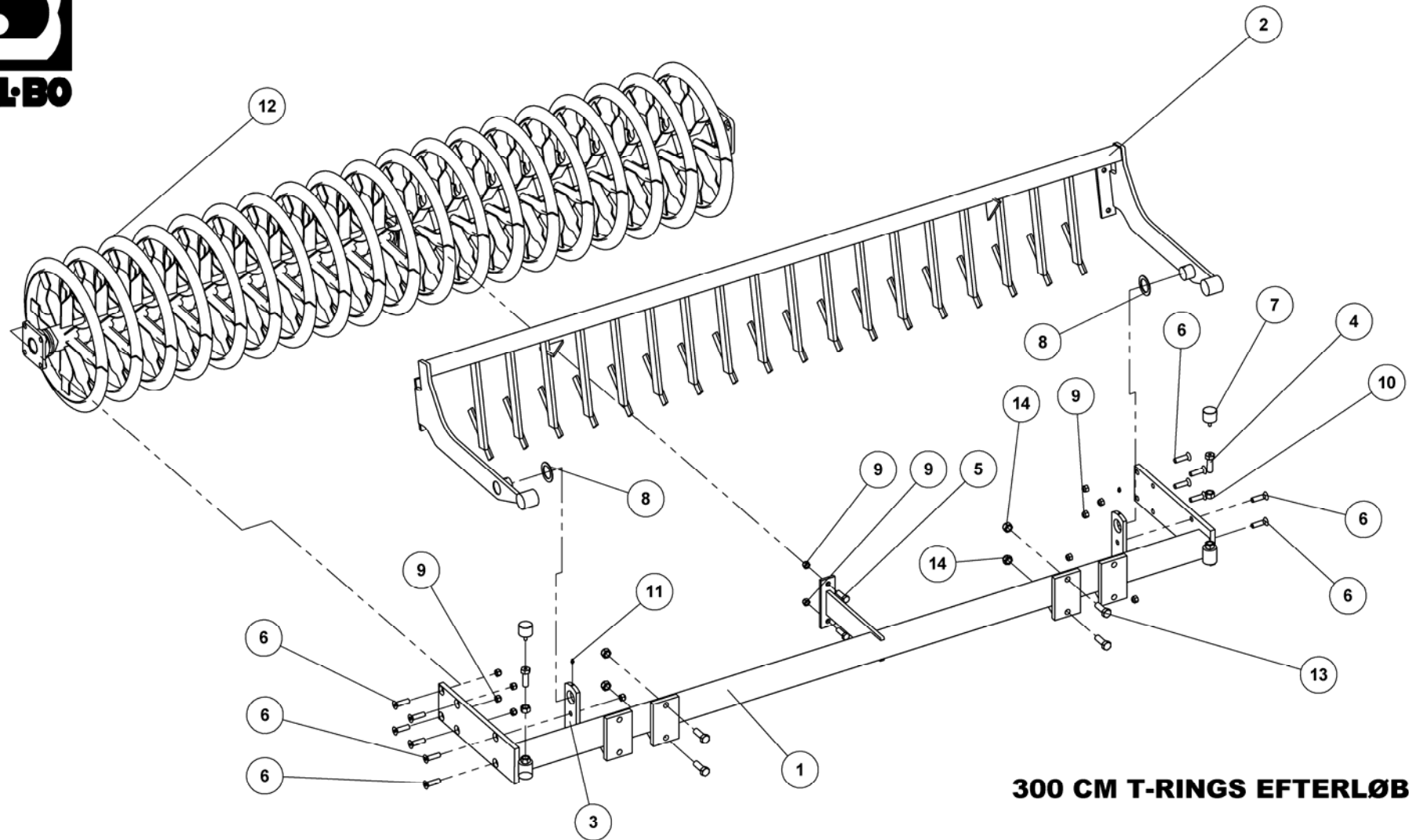

300 CM T-RINGS EFTERLØBER

2930

NÄCHLAUFER
ROLLER, T-RING
TRAINE, ANNEAU-T

76063



300 CM T-RINGS EFTERLØBER

76063

NÄCHLAUFER
ROLLER, T-RING
TRAINE, ANNEAU-T

2930

Pos.	Qty.	Part nr.	Benævnelse	Bezeichnung	Description	Designation
1	1	76271	T-RINGS RAMME 300CM	T-RING RAHMEN	T-RING FRAME	CHASSIS D'ANNEAU-T
2	1	76281	AFSKRABER BOM TIL 300CM	BARRE DU SYSTÈME DE RACLAGE	SCRAPER GANG FOR 300CM	ABSTREIFER-BALKEN
3	2	76475	BOLTEFÆST. T/F-JERNS KRYMLER	BEFESTIGUNG	BOLTED PLATE FOR F-IRON CAGE ROLLER	FIXATION DE BOULON POUR ROULEAU DE FER EN F
4	2	76476	BOLT T/GUMMIKLODS JUSTERING	SCHRAUBE	RUBBER BLOCK ADJUSTMENT SCREW	BOULON
5	2	92317	BOLT 16x50 8.8 GALV. (SÆTBOLT)	SCHRAUBE	SET SCREW	BOULON
6	12	92420	BOLT 16x60 GALV. 8.8 UNDERSÆNKET	SCHRAUBE	COUNTERSUNK SCREW	BOULON
7	2	85375	GUMMIKLODS	GUMMIKLOTZ	RUBBER BLOCK	BLOC EN CAOUTCHOUC
8	2	51349	SKIVE Ø51-Ø75-3 Glv	SCHLEIFE	WASHER	RONDELLE
9	14	92051	MØTRIK M16 SELVLÅS. GLV.8	MUTTER	SELF-LOCKING NUT	ÉCROU
10	2	92032	MØTRIK M20 GALV. kl.8	MUTTER	NUT	ÉCROU
11	2	90721	SMØRENIPPEL M8x1	SCHMIERNIPPEL	GREASE NIPPLE	GRAISSEUR
12	1	76220	T-RING PÅ AKSEL, 300	SATZ RINGE FÜR DIE ACHSE	SHAFT RING SET	ANNEAUX SUR ARBRE
13	4	92334	BOLT 20x60 8.8 GALV.	SCHRAUBE	SCREW	BOULON
14	4	92052	MØTRIK M 20 SELVLÅS. GALV. 8	MUTTER SELBSTGESICHERT	SELF-LOCKING NUT	ÉCROU DE SÉCURITÉ

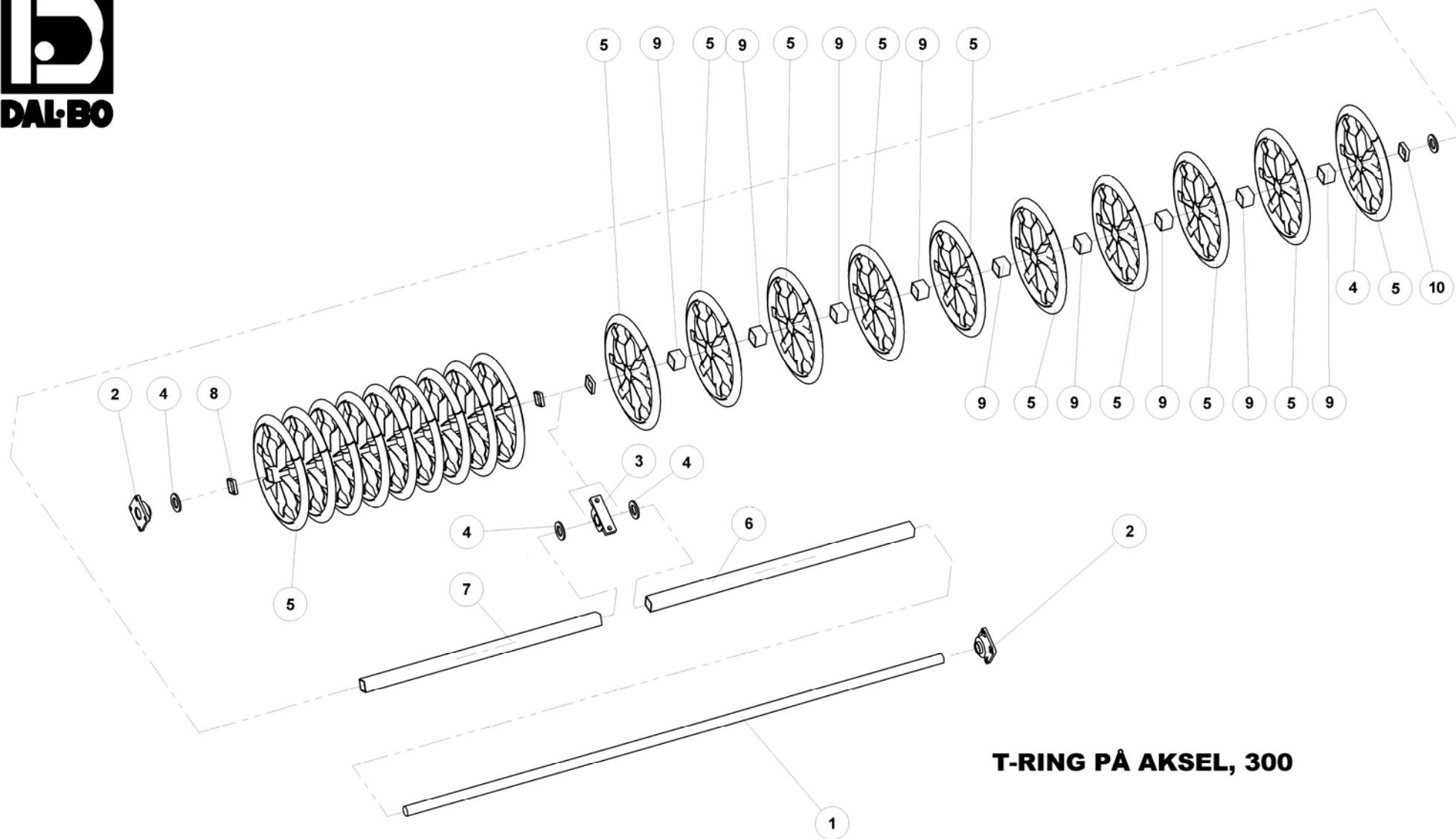

T-RING PÅ AKSEL, 300

SATZ RINGE FÜR DIE ACHSE
SHAFT RING SET
ANNEAUX SUR ARBRE

76220



T-RING PÅ AKSEL, 300

76220

SATZ RINGE FÜR DIE ACHSE
SHAFT RING SET
ANNEAUX SUR ARBRE

Pos.	Qty.	Part nr.	Benævnelse	Bezeichnung	Description	Designation
1	1	76465	AKSEL Ø 50 X 2965	ARBRE	SHAFT	ACHSE
2	2	12391	KOMPLET Y-LEJE FY 50 TL	KOMPLETTES Y-LAGER	COMPLETE Y-BEARING	PALIER-Y COMPLET
3	1	12390	KOMPLET Y-LEJE SY 50 TL	KOMPLETTES Y-LAGER	COMPLETE Y-BEARING	PALIER-Y COMPLET
4	4	90674	SKIVE Ø52-Ø92-8	UNTERLEGSCHIEBE	WASHER	RONDELLE DE SERRAGE
5	19	90875	T-RING Ø600MM. M. FIRK. -NAV 89 MM	T-RINGE	T-RING	ANNEAU-T
6	1	93025145590L90LX	FIRK-RØR 60X60X4-1455 ST. 44.2	VIERKANT ROHR	SQUARE TUBE	TUBE CARRÉ
7	1	93025130590L90LX	FIRK-RØR 60X60X4-1305 ST. 44.2	VIERKANT ROHR	SQUARE TUBE	TUBE CARRÉ
8	3	90381	FIRKANT-RØR 70X70X4-15	VIERKANT ROHR	SQUARE TUBE	TUBE CARRÉ
9	17	90388	FIRK-RØR 70X70X4-60 ST. 44.2	VIERKANT ROHR	SQARE TUBE	TUBE CARRÉ
10	1	90382	FIRKANT-RØR 70X70X4-20	VIERKANT ROHR	SQUARE TUBE	TUBE CARRÉ

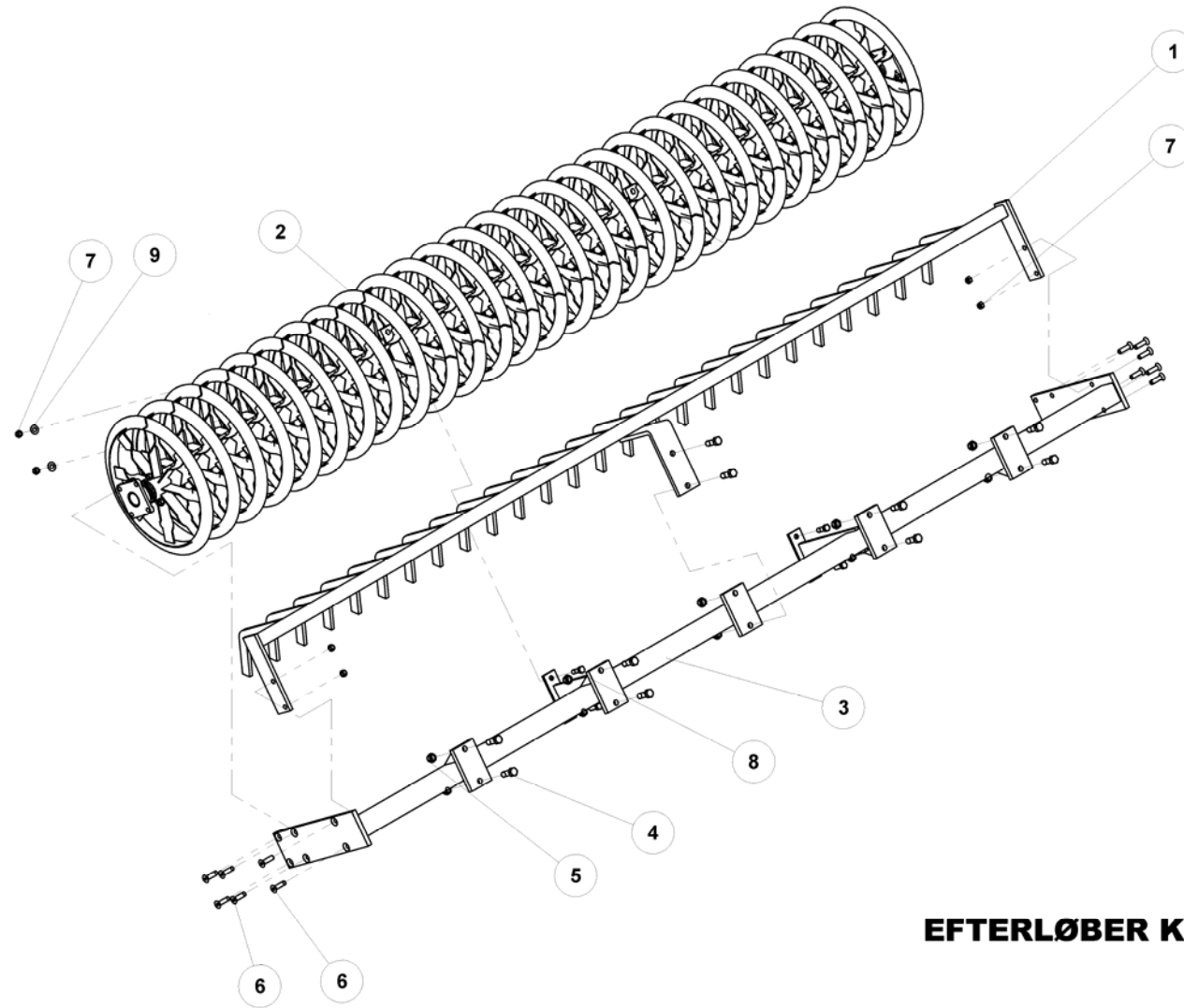

EFTERLØBER KPL. 400 CM

NÄCHLAUFER
ROLLER, T-RING
TRAINE, ANNEAU-T

80424



EFTERLØBER KPL. 400 CM

80424

NÄCHLAUFER
ROLLER, T-RING
TRAINE, ANNEAU-T

Pos.	Qty.	Part nr.	Benævnelse	Bezeichnung	Description	Designation
1	1	80401	AFSKRABERBOM 400 CM MAXIDISC	ABSTREIFER-BALKEN	SCRAPER GANG	BARRE DU SYSTÈME DE RACLAGE
2	1	80405	SÆT RINGE PÅ AKSEL 400X60	SATZ RINGE FÜR DIE ACHSE	SHAFT RING SET	ANNEAUX SUR ARBRE
3	1	80403	KRYMLERRAMME 400 CM MAXIDISC	KRÜMLERRAHMEN	CAGE ROLLER	CADRE DE ROULEAU DE NIVELLEMENT
4	10	92334	BOLT 20x60 8.8 GALV.	SCHRAUBE	SCREW	BOULON
5	10	92052	MØTRIK M 20 SELVLÅS. GALV. 8	MUTTER SELBSTGESICHERT	SELF-LOCKING NUT	ÉCROU DE SÉCURITÉ
6	12	92420	BOLT 16x60 GALV. 8.8 UNDERSÆNKET	SCHRAUBE	COUNTERSUNK SCREW	BOULON
7	16	92051	MØTRIK M16 SELVLÅS. GLV.8	MUTTER	SELF-LOCKING NUT	ÉCROU
8	4	92317	BOLT 16x50 8.8 GALV. (SÆTBOLT)	SCHRAUBE	SET SCREW	BOULON
9	4	90663	SKIVE Ø17-Ø35-2	UNTERLEGSCHIEBE	WASHER	RONDELLE DE SERRAGE

T-rings efterløber 300x60, roller, nachläufer, train

EFTERLØBER KPL. 300 CM

76059

Nächläufer
Toller, T-ring
Trainee, anneau-T

Pos.	Qty.	Part nr.	Benævnelse	Bezeichnung	Description	Designation
1	1	80917	Afskraber	Abstreifer-balken	Scraper gang	Barre du système de raclage
2	1	74075	Sæt ringe på aksle	Satz ringe für die achse	Shaft ring set	Anneaux sur arbre
3	1	80916	Krymlerramme	Krümlerrahmen	Cage roller	Cadre de rouleau de nivellement

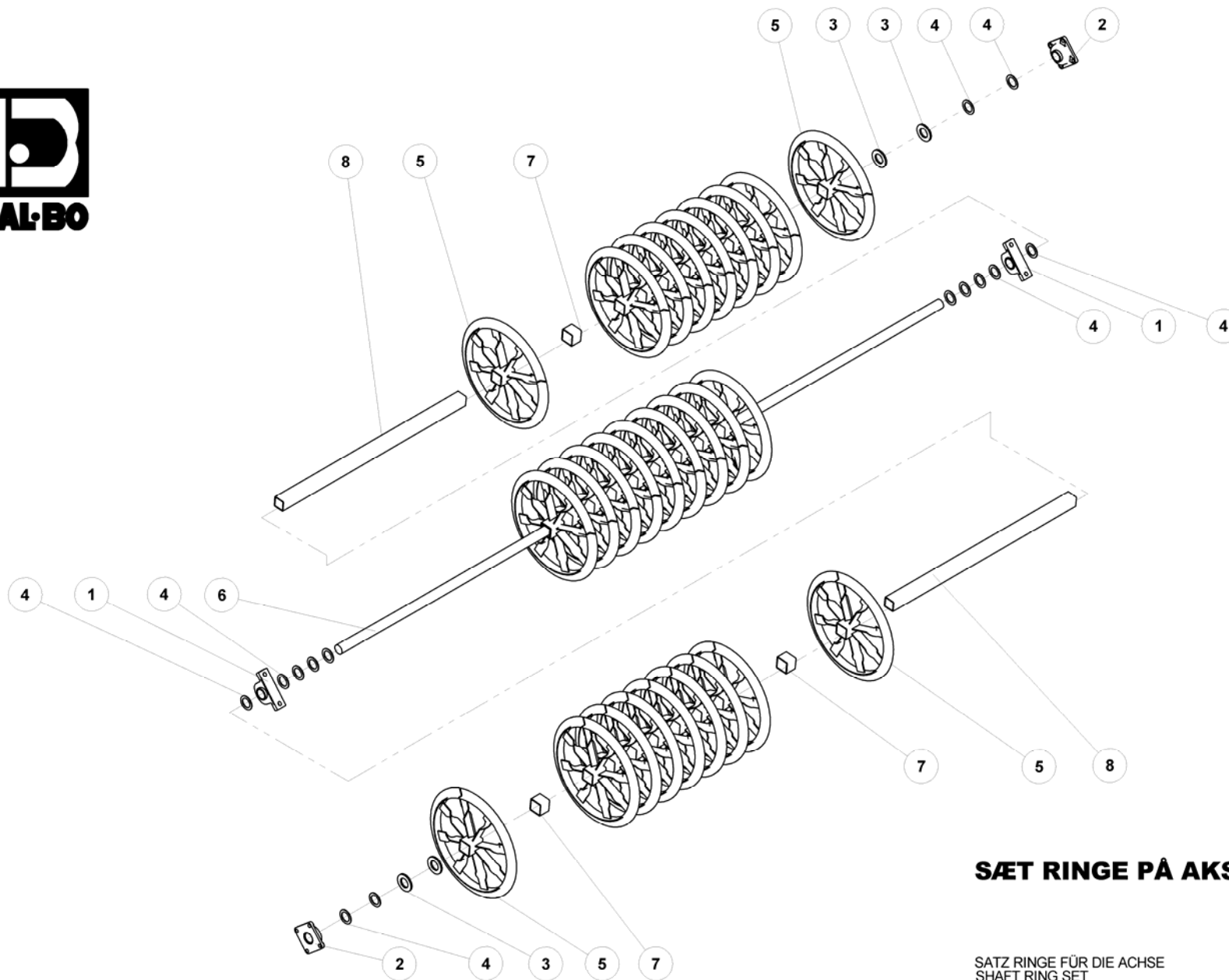

SÆT RINGE PÅ AKSEL 400X60

SATZ RINGE FÜR DIE AKHSE
SHAFT RING SET
ANNEAUX SUR ARBRE

80405



SÆT RINGE PÅ AKSEL 400X60

80405

SATZ RINGE FÜR DIE ACHSE
SHAFT RING SET
ANNEAUX SUR ARBRE

Pos.	Qty.	Part nr.	Benævnelse	Bezeichnung	Description	Designation
1	2	12390	KOMPLET Y-LEJE SY 50 TL	KOMPLETTES Y-LAGER	COMPLETE Y-BEARING	PALIER-Y COMPLET
2	2	12391	KOMPLET Y-LEJE FY 50 TL	KOMPLETTES Y-LAGER	COMPLETE Y-BEARING	PALIER-Y COMPLET
3	4	90674	SKIVE Ø52-Ø92-8	UNTERLEGSCHIEBE	WASHER	RONDELLE DE SERRAGE
4	14	51349	SKIVE Ø51-Ø75-3 Glv	SCHEIBE	WASHER	RONDELLE
5	27	90875	T-RING Ø600MM. M. FIRK. -NAV 89 MM	T-RINGE	T-RING	ANNEAU-T
6	1	80604	AKSEL Ø50 MM - L=4150	WELLE	SHAFT	ARBRE
7	24	93030	FIRK-RØR 70X70X4-60 ST. 44.2	VIERKANT ROHR	SQARE TUBE	TUBE CARRÉ
8	3	93025	FIRK-RØR 60X60X4-1260 ST. 44.2	VIERKANT ROHR	SQUARE TUBE	TUBE CARRÉ

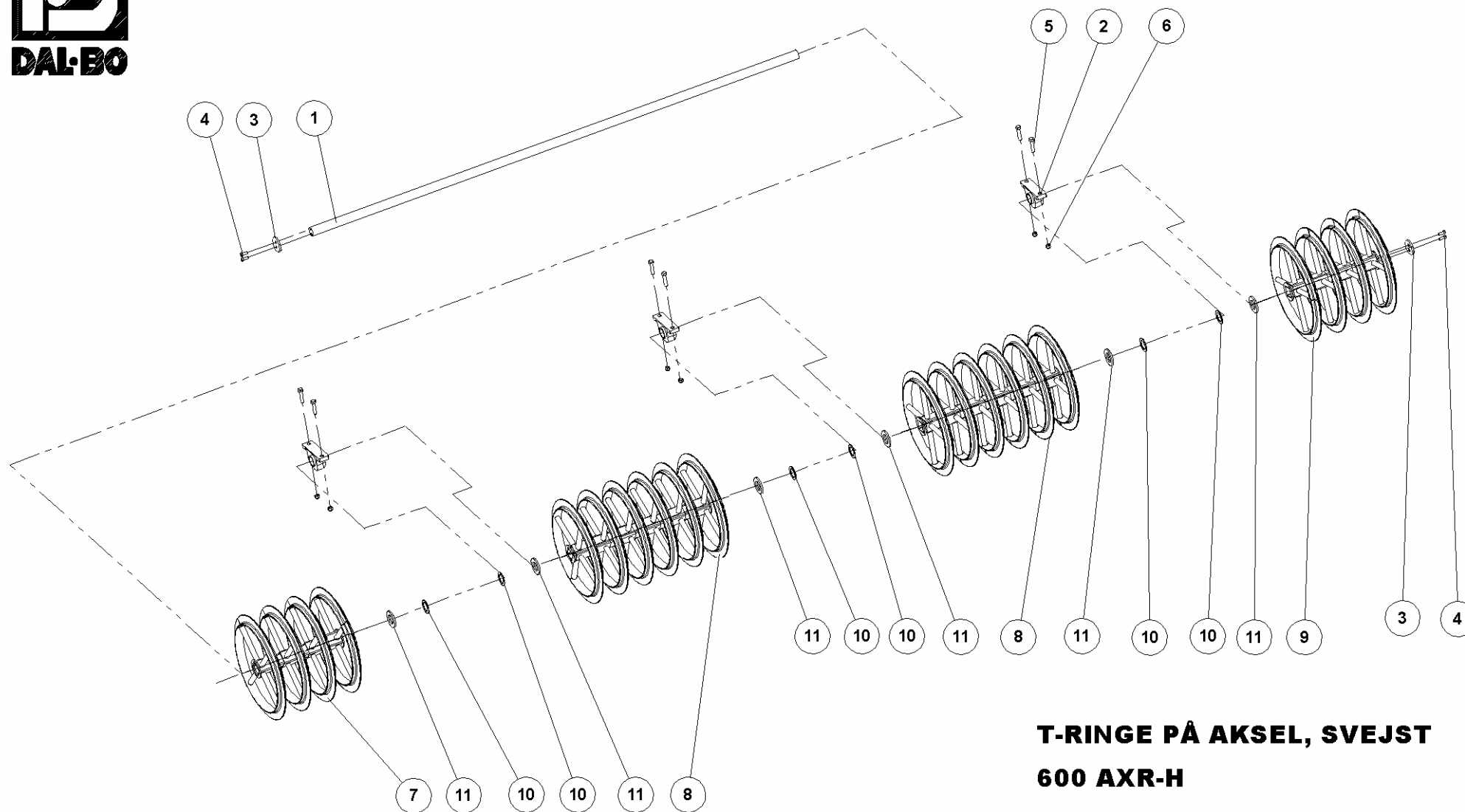

T-RINGE PÅ AKSEL, SVEJST 600 AXR-H

SATZ RINGE FÜR DIE ACHSE
SHAFT RING SET
ANNEAUX SUR ARBRE

74075



T-RINGE PÅ AKSEL, SVEJST

600 AXR-H

74075

SATZ RINGE FÜR DIE ACHSE
SHAFT RING SET
ANNEAUX SUR ARBRE

Pos.	Qty.	Part nr.	Benævnelse	Bezeichnung	Description	Designation
1	1	74237	AKSEL TIL EFTERLØBER 600 2910 MM	ACHSE FÜR DEN NACHLÄUFER	SHAFT FOR TOWED ROLLER	ARBRE POUR TRAÎNE
2	3	12390	KOMPLET Y-LEJE SY 50 TL	KOMPLETTES Y-LAGER	COMPLETE Y-BEARING	PALIER-Y COMPLET
3	2	90092	SKIVE TIL 50 MM AKSELENDE	SCHEIBE	WASHER	RONDELLE
4	4	92541	BOLT 12x30 GALV 12.9 (SÆTBOLT)	SCHRAUBE	SET SCREW	BOULON
5	6	92319	BOLT 16x70 8.8 GALV.	SCHRAUBE	SCREW	BOULON
6	6	92051	MØTRIK M16 SELVLÅS. GLV.8	MUTTER	SELF-LOCKING NUT	ÉCROU
7	1	74084	T-RINGE PÅ AKSEL 600, SVEJST	SATZ RINGE FÜR DIE ACHSE	SHAFT RING SET	ANNEAUX SUR ARBRE
8	2	74082	T-RINGE PÅ AKSEL, SVEJST	SATZ RINGE FÜR DIE ACHSE	SHAFT RING SET	ANNEAUX SUR ARBRE
9	1	74086	T-RINGE PÅ AKSEL 600, SVEJST	SATZ RINGE FÜR DIE ACHSE	SHAFT RING SET	ANNEAUX SUR ARBRE
10	6	51349	SKIVE Ø51-Ø75-3 GIV	SCHEIBE	WASHER	RONDELLE
11	6	90674	SKIVE Ø52-Ø92-8	UNTERLEGSCHIEBE	WASHER	RONDELLE DE SERRAGE

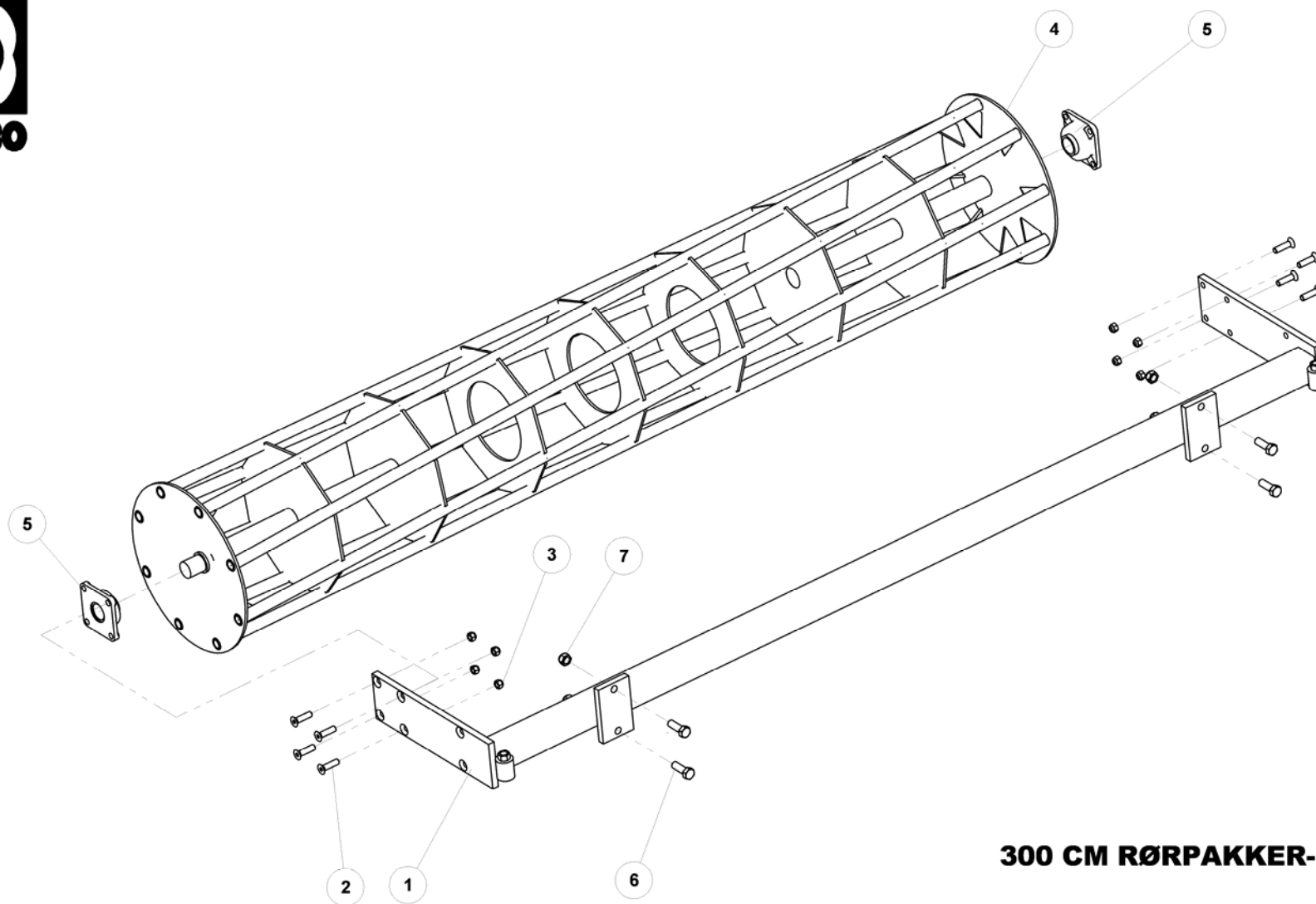

300 CM RØRPAKKER-EFTERLØBER

2930



300 CM RØRPAKKER-EFTERLØBER

NACHLÄUFER
ROLLER
TRAÎNE

2930

Pos.	Qty.	Part nr.	Benævnelse	Bezeichnung	Description	Designation
1	1	75368	KRYMLERRAMME 300 CM	KRÜMLERRAHMEN	CAGE ROLLER	CADRE DE ROULEAU DE NIVELLEMENT
2	8	92420	BOLT 16x60 GALV. 8.8 UNDERSÆNKET	SCHRAUBE	COUNTERSUNK SCREW	BOULON
3	8	92051	MØTRIK M16 SELVLÅS. GLV.8	MUTTER	SELF-LOCKING NUT	ÉCROU
4	1	75380	KRYMLER - 300CM	KRÜMLER	CAGE ROLLER	ROULEAU DE NIVELLEMENT
5	2	12391	KOMPLET Y-LEJE FY 50 TL	KOMPLETTES Y-LAGER	COMPLETE Y-BEARING	PALIER-Y COMPLET
6	4	92334	BOLT 20x60 8.8 GALV.	SCHRAUBE	SCREW	BOULON
7	4	92052	MØTRIK M 20 SELVLÅS. GALV. 8	MUTTER SELBSTGESICHERT	SELF-LOCKING NUT	ÉCROU DE SÉCURITÉ

Ekstraudstyr, options

F-jerns krymler til T-ringefterløber, flat iron cage roller, f-eisen krümler, rouleau de nivellement de fer en f

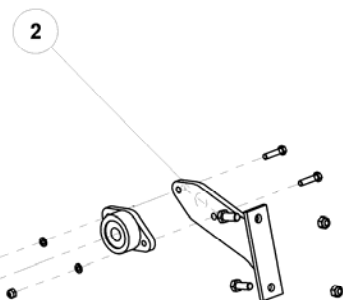
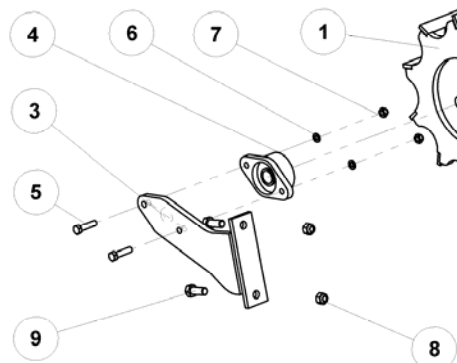
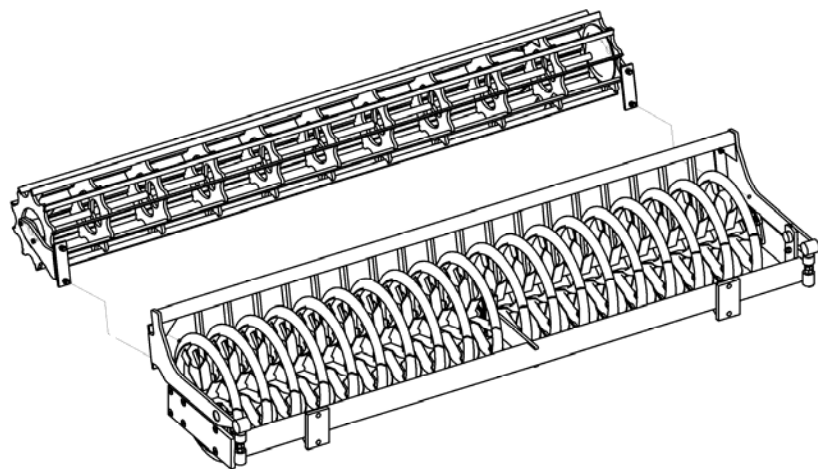

F-JERNS KRYMLER FOR 300 CM T-RING

F-EISEN KRÜMLER

ROULEAU DE NIVELLEMENT DE FER EN F



F-JERNS KRYMLER FOR 300 CM

T-RING

F-EISEN KRÜMLER

ROULEAU DE NIVELLEMENT DE FER EN F

Pos.	Qty.	Part nr.	Benævnelse	Bezeichnung	Description	Designation
1	1	76367	F-JERNS KRYMLER 300CM	ROULEAU DE NIVELLEMENT DE FER EN F	F-IRON CAGE ROLLER	F-EISEN KRÜMLER
2	1	76287	LEJEPLADE TIL F-JERNS KRYMLER VENSTRE	LAGERPLATTE FÜR F-EISEN KRÜMLER LINKS	BEARING PLATE, F-IRON CAGE ROLLER, LEFT	SEMELLE DE PALIER DU ROULEAU DE FER EN F GAUCHE
3	1	76288	LEJEPLADE TIL F-JERNS KRYMLER HØJRE	LAGERPLATTE FÜR F-EISEN KRÜMLER RECHTS	BEARING PLATE, F-IRON CAGE ROLLER, RIGHT	SEMELLE DE PALIER DU ROULEAU DE FER EN F DROITE
4	2	21398	FLANGELEJE FYTB Ø30 TF	FLANSCHEN LAGER	FLANGE BEARING	PALIER A AILE
5	4	92297	BOLT 12x50 8.8 GALV.	SCHRAUBE	SCREW	BOULON
6	4	90669	SKIVE Ø13-Ø24-2,5	UNTERLEGSCHIEBE	WASHER	RONDELLE DE SERRAGE
7	4	92050	MØTRIK M12 SELVLÅS. GLV. 8	MUTTER SELBSTSCHLIESSEND	SELFLOCKING NUT	ÉCROU DE SÉCURITÉ
8	4	92051	MØTRIK M16 SELVLÅS. GLV.8	MUTTER	SELF-LOCKING NUT	ÉCROU
9	4	92316	BOLT 16x40 8.8 GALV. (SÆTBOLT)	SCHRAUBE	SET SCREW	BOULON

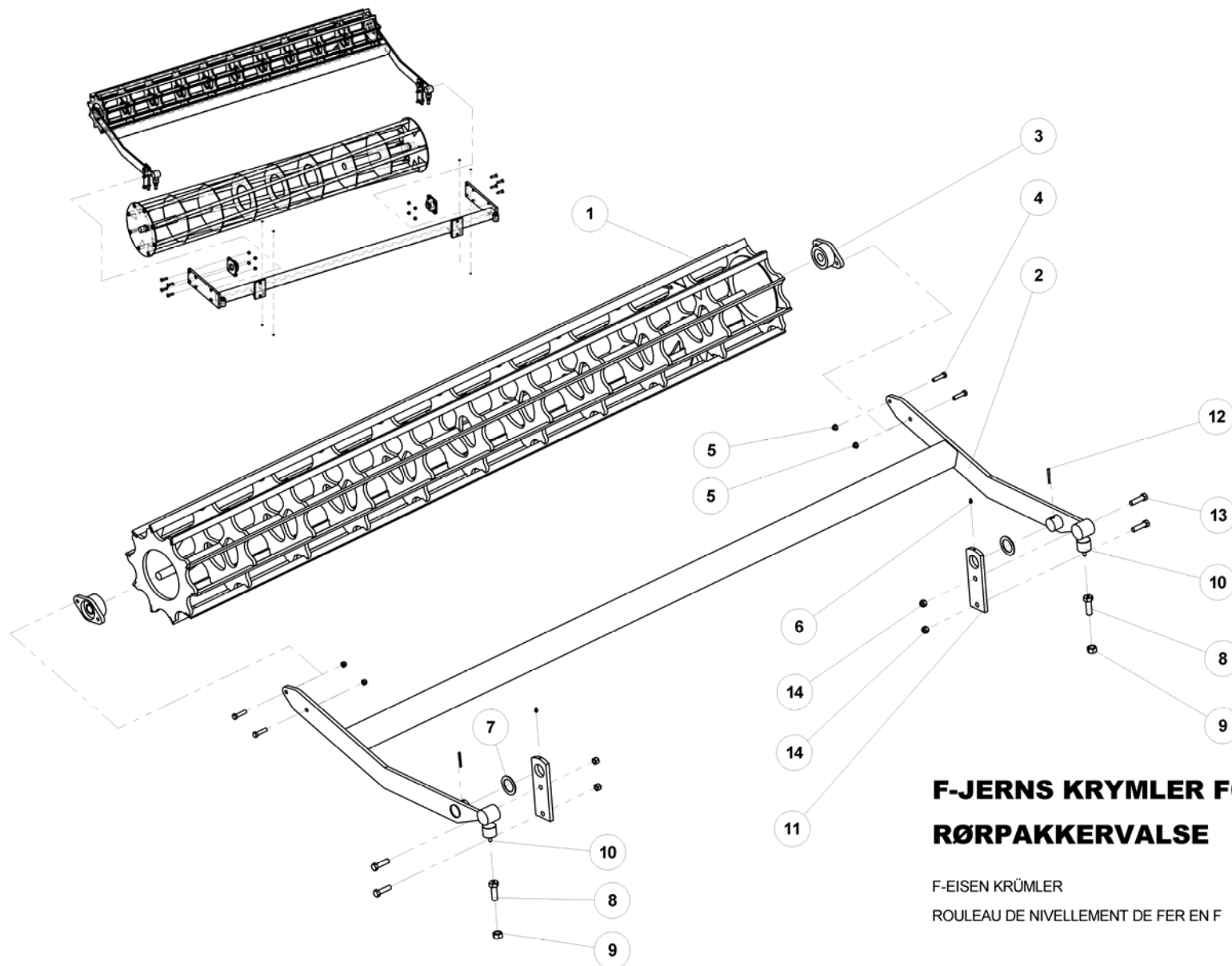

F-JERNS KRYMLER FOR 300 CM RØRPAKKERVÅLSE

F-EISEN KRÜMLER
ROULEAU DE NIVELLEMENT DE FER EN F



F-JERNS KRYMLER FOR 300 CM

RØRPAKKERVÅLSE

F-EISEN KRÜMLER

ROULEAU DE NIVELLEMENT DE FER EN F

Pos.	Qty.	Part nr.	Benævnelse	Bezeichnung	Description	Designation
1	1	76367	F-JERNS KRYMLER 300CM	ROULEAU DE NIVELLEMENT DE FER EN F	F-IRON CAGE ROLLER	F-EISEN KRÜMLER
2	1	76353	F-jærns krymlerramme, 300 cm	KRÜMLERRAHMEN	CAGE ROLLER	CADRE DE ROULEAU DE NIVELLEMENT
3	2	21398	FLANGELEJE FYTB Ø30 TF	FLANSCHEN LAGER	FLANGE BEARING	PALIER A AILE
4	4	92297	BOLT 12x50 8.8 GALV.	SCHRAUBE	SCREW	BOULON
5	4	92050	MØTRIK M12 SELVLÅS. GLV. 8	MUTTER SELBSTSCHLIESSEND	SELFLOCKING NUT	ÉCROU DE SÉCURITÉ
6	2	90721	SMØRENIPPEL M8x1	SCHMIERNIPPEL	GREASE NIPPLE	GRAISSEUR
7	2	51349	SKIVE Ø51-Ø75-3 Glv	SCHEIBE	WASHER	RONDELLE
8	2	76476	BOLT T/GUMMIKLODS JUSTERING	SCHRAUBE	RUBBER BLOCK ADJUSTMENT SCREW	BOULON
9	2	92032	MØTRIK M20 GALV. kl.8	MUTTER	NUT	ÉCROU
10	2	85375	GUMMIKLODS	GUMMIKLOTZ	RUBBER BLOCK	BLOC EN CAOUTCHOUC
11	2	76475	BOLTEFÆST. T/F-JERNS KRYMLER	BEFESTIGUNG	BOLTED PLATE FOR F-IRON CAGE ROLLER	FIXATION DE BOULON POUR ROULEAU DE FER EN F
12	2	90688	RØRSTIFT Ø 6X60 MM	ROHRSTIFT	SPLIT PIN	AXE TUBULAIRE
13	4	92318	BOLT 16x60 8.8 GALV.	SCHRAUBE	SCREW	BOULON
14	4	92051	MØTRIK M16 SELVLÅS. GLV.8	MUTTER	SELF-LOCKING NUT	ÉCROU

Hydraulik

Tand med NSH, tooth cpl, zinken kompl. Hydraulisch, dent cpl hydraulique

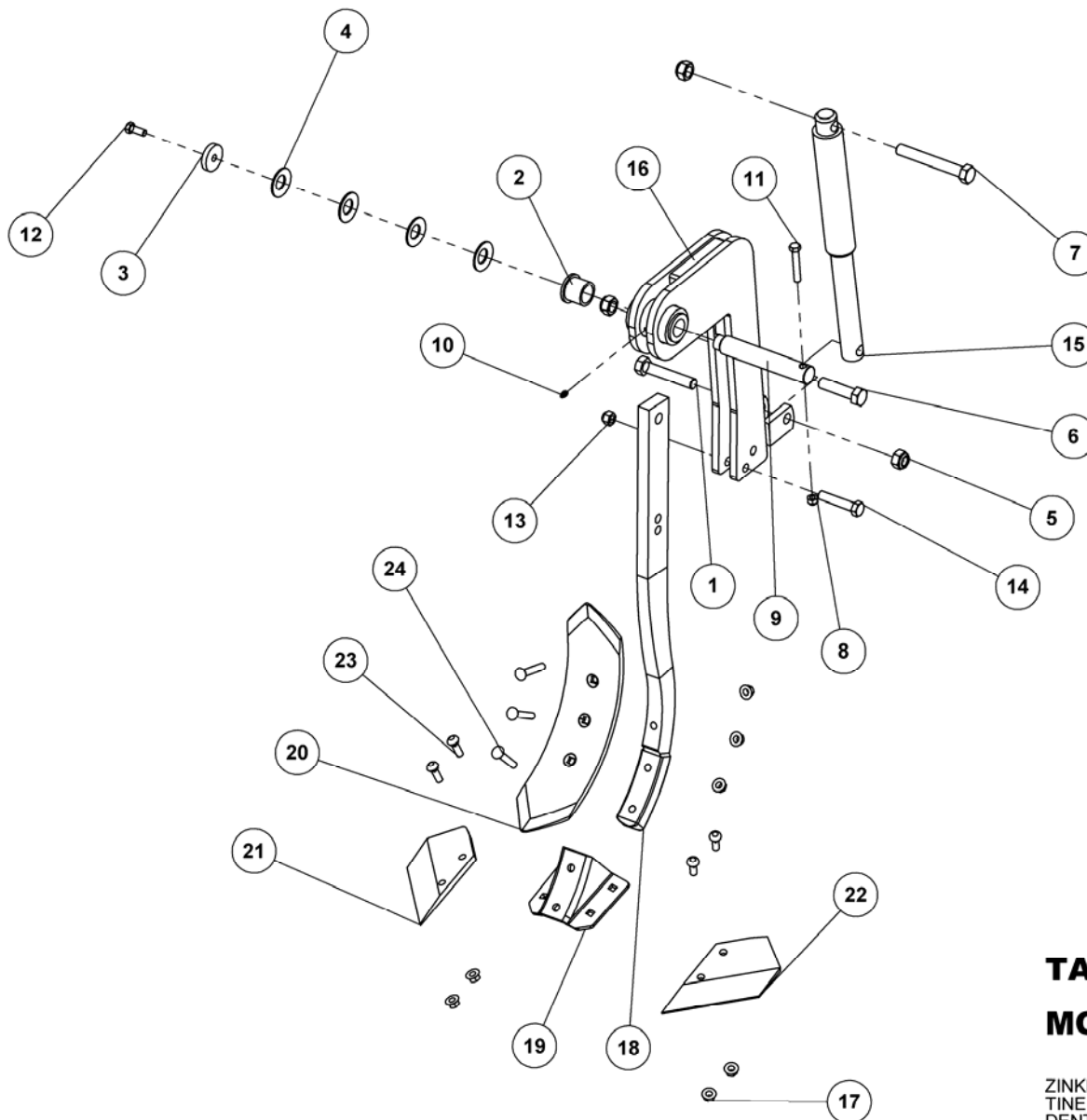

**TAND KPL. M. HYDR.
MODEL 3 BULLET**

ZINKEN
TINE
DENT

76268



TAND KPL. M. HYDR.

MODEL 3 BULLET

76268

ZINKEN
TINE
DENT

Pos.	Qty.	Part nr.	Benævnelse	Bezeichnung	Description	Designation
1	2	92598	BOLT 20x110 10.9 GALV.	SCHRAUBE	SCREW	BOULON
2	2	91910	BRONCEBØSNING AM-B35-45-40/55-5	BUCHSE	BUSHING	DOUILLE
3	1	76456	SKIVE Ø13-Ø51-10	SHEIBE	WASHER	RONDELLE
4	4	76200	TALLERKENFJEDER Ø56/Ø28,5 x 3,0	SCHEIBENFEDER	DISC SPRING	RESSORT DE DISQUE
5	3	92052	MØTRIK M 20 SELVLÅS, GALV. 8	MUTTER SELBSTGESICHERT	SELF-LOCKING NUT	ÉCROU DE SÉCURITÉ
6	1	92336	BOLT 20 X 80 8.8 GALV.	SCHRAUBE	SCREW	BOULON
7	1	92338	BOLT 20x150 8.8 GALV.	SCHRAUBE	SCREW	BOULON
8	1	92050	MØTRIK M12 SELVLÅS, GLV. 8	MUTTER SELBSTSCHLIESSEND	SELFLOCKING NUT	ÉCROU DE SÉCURITÉ
9	1	77646	NAGLE Ø35x210	BOLZEN	PIN	AXE
10	1	90721	SMØRENIPPEL M8x1	SCHMIERNIPPEL	GREASE NIPPLE	GRAISSEUR
11	1	92299	BOLT 12x70 8.8 GALV.	SCHRAUBE	SCREW	BOULON
12	1	92295	BOLT 12x30 8.8 GALV. (SÆTBOLT)	SCHRAUBE	SET SCREW	BOULON
13	1	92051	MØTRIK M16 SELVLÅS, GLV. 8	MUTTER	SELF-LOCKING NUT	ÉCROU
14	1	92320	BOLT 16x80 8.8 GALV.	SCHRAUBE	SCREW	BOULON
15	1	91856	CYLINDER 40X40X200	ZYLINDER	RAN	VERRIN
16	1	77618	TANDHOLDER KPL.	ZINKENHALTER	TINE MOUNT	SUPPORT DE DENTS
17	7	92520	MØTRIK M12 - FLANGE 10 (SIKRINGSMØTRIK)	MUTTER	LOCK NUT	ÉCROU
18	1	76250	STIELE 60X25 - DAL-BO 2000	STIELE	HANDLE	TIGE
19	1	76252	VINGEKONSOL 8MM - DAL-BO 2000	SCHAR KONSOLE	WING CONSOLE	CONSOLE D'AILE
20	1	76261	STUBSPIDS LIGE 120X10 - DAL-BO 200	SPITZE	POINT, STRAIGHT	POINTE RIGIDE DROITE
21	1	76267	VINGESKÆR HØJRE - DAL-BO 2005	FLÜGELSCHAR RECHTS	WING PLOUGHSHARE, RIGHT	SOC À AILES LONGUES DROITE
22	1	76266	VINGESKÆR VENSTRE - DAL-BO 2005	FLÜGELSCHAR LINKS	WING PLOUGHSHARE, LEFT	SOC À AILES LONGUES GAUCHE
23	4	92737	BOLT 12X35 10.9 (BRÆDDEROLT)	SCHRAUBE (BRETTSCHRAUBE)	BOARD BOLT	BOULON
24	3	75265	PLOVBOLT M12X70 10.9	BOLZEN 10.9 (PFLUG)	PLOW BOLT	BOULON 10.9

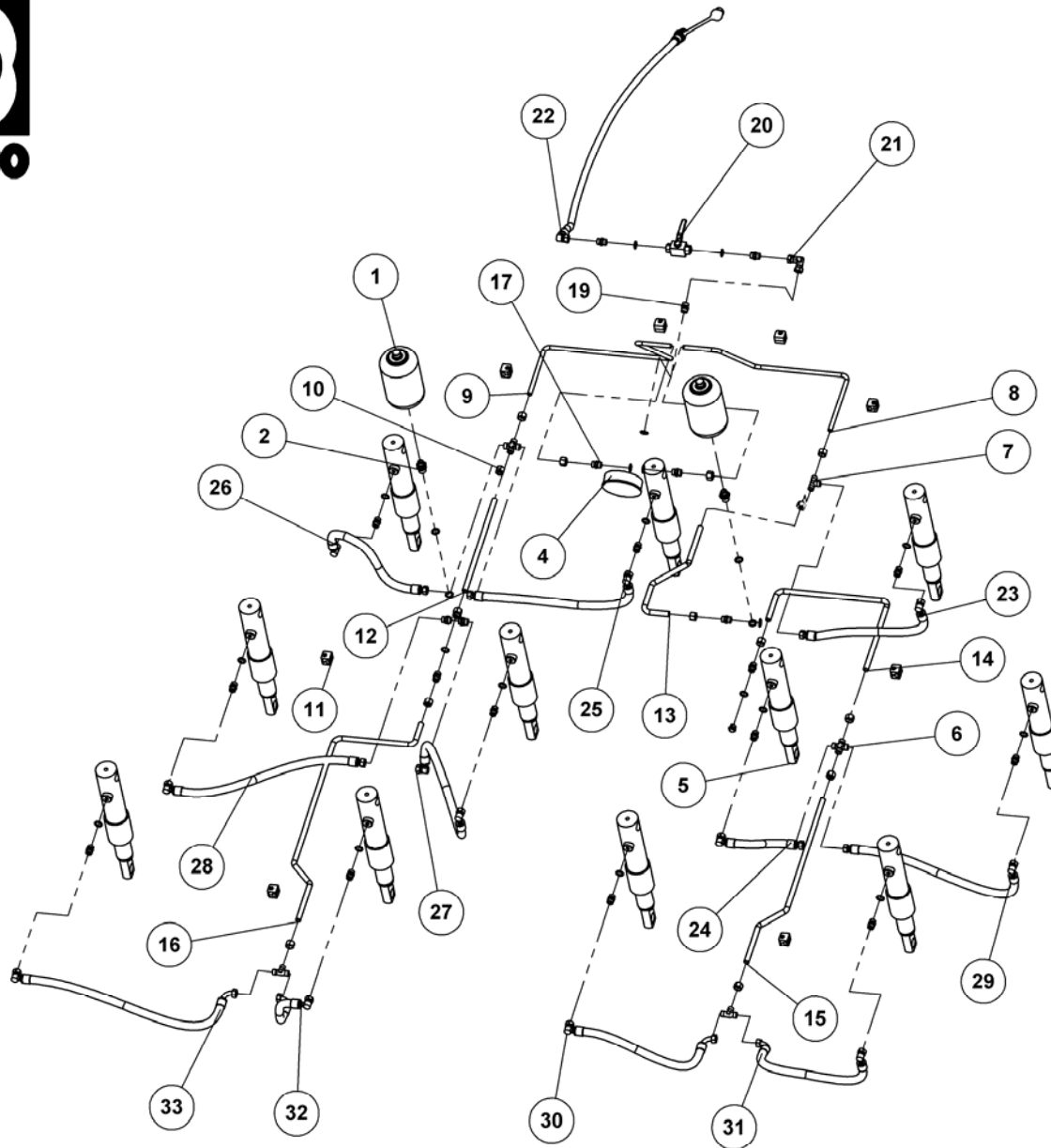

**DINCO 300 CM NSH
MODEL 3 BULLET**

STEIN SICHERUNG
STONE SAFETY
SECURITE

75128



DINCO 300 CM NSH

STEIN SICHERUNG
STONE SAFETY
SECURITE

MODEL 3 BULLET

75128

Pos.	Qty.	Part nr.	Benævnelse	Bezeichnung	Description	Designation
1	2	91262	AKKUMULATOR 1 L H1000R - 120 BAR	AKKUMULATOR	ACCUMULATOR	ACCUMULATEUR
2	2	91074	BRYSTNIPPEL 1/2"RG /3/8"RG GALV	VERSCHRAUBUNG	HEXAGON NIPPLE CONNECTOR	RACCORD DE JONCTIONS MÂLES
3	26	91028	3/8" BONDED SEALS PAKRING	BONDED SEALS PACKRING	BONDED SEAL WASHER	JOINT BONDED SEALS
4	1	91256	MANOMETER 1/4" RG	MANOMETER	MANOMETER	MANOMÈTRE
5	11	76205	CYLINDER 55/50X100X100 PLUNGER SPEC.	ZYLINDER	CYLINDER	CYLINDRE
6	2	91007	KRYDS M18 Ø12 GALV. P-KV 12L	KREUZ	CROSS	CROIX
7	3	91006	T-STYKKE M18X1.5 P-TV 12L	T-STÜCK	T-PIECE	T-PIÈCE
8	1	93140100090L90LX	HYDRAULIKRØR 12X1.5	HYDR. ROHR	HYDR. TUBE	TUBE HYDR.
9	1	93140113090L90LX	HYDRAULIKRØR 12X1.5	HYDR. ROHR	HYDR. TUBE	TUBE HYDR.
10	14	91103	OMLØBER M/SKÆRERING M18	VERSCHRAUBUNG	ADAPTOR	RACCORD
11	8	91311	PLASTKLAMME, BOLT 12MM KPL	PLASTIK KLAMMER	PLASTIC HOSE CLAMP	CROCHET EN PLASTIQUE
12	1	93140036090L90LX	HYDRAULIKRØR 12X1.5	HYDR. ROHR	HYDR. TUBE	TUBE HYDR.
13	1	93140053090L90LX	HYDRAULIKRØR 12X1.5	HYDR. ROHR	HYDR. TUBE	TUBE HYDR.
14	1	93140075090L90LX	HYDRAULIKRØR 12X1.5	HYDR. ROHR	HYDR. TUBE	TUBE HYDR.
15	1	93140070090L90LX	HYDRAULIKRØR 12X1.5	HYDR. ROHR	HYDR. TUBE	TUBE HYDR.
16	1	93140110090L90LX	HYDRAULIKRØR 12X1.5	HYDR. ROHR	HYDR. TUBE	TUBE HYDR.
17	8	91003	BRYSTNIPPEL M18 / 3/8" RG GALV.	VERSCHRAUBUNG	HEXAGON NIPPLE CONNECTOR	RACCORD DE JONCTIONS MÂLES
18	1	91093	SLUTPROP M/PAKNING 3/8"	SCHLUSSSTÖPSEL	END PLUG	BOLICHON DE FERMETURE
19	14	91002	BRYSTNIPPEL 3/8"RG / 3/8"RG GALV	VERSCHRAUBUNG	HEXAGON NIPPLE CONNECTOR	RACCORD DE JONCTIONS MÂLES
20	1	50573	VENTIL KH-R 3/8 NW10 ORSTA	KUGELHAHN	VALVE	VANETTE 3/8"
21	1	91067	VINKEL 3/8" 90 FEMALE/FEMALE	WINKEL	CONNECTOR	ANGLE
22	1	77591	SLANGE HAN/VINKEL 3/8 L=2000 MM	SCHLAUCH	HOSE	TUYAU
23	1	77583	SLANGE VINKEL 3/8"/LIGE M18 L=420 MM	SCHLAUCH	HOSE	TUYAU
24	1	77582	SLANGE VINKEL 3/8"/LIGE M18 L=340 MM	SCHLAUCH	HOSE	TUYAU
25	1	77586	SLANGE VINKEL 3/8"/LIGE M18 L=540 MM	SCHLAUCH	HOSE	TUYAU
26	1	77580	SLANGE VINKEL 3/8"/LIGE M18 L=300 MM	SCHLAUCH	HOSE	TUYAU
27	1	77584	SLANGE VINKEL 3/8"/VINKEL 3/8" L=450 MM	SCHLAUCH	HOSE	TUYAU
28	1	77589	SLANGE VINKEL 3/8"/LIGE 3/8" L=800MM	SCHLAUCH	HOSE	TUYAU
29	1	77588	SLANGE VINKEL 3/8"/LIGE M18 L=620 MM	SCHLAUCH	HOSE	TUYAU
30	1	77585	SLANGE VINKEL 3/8"/VINKEL M18 L=450 MM	SCHLAUCH	HOSE	TUYAU
31	1	77587	SLANGE VINKEL 3/8"/VINKEL M18 L=600 MM	SCHLAUCH	HOSE	TUYAU
32	1	77581	SLANGE VINKEL 3/8"/VINKEL M18 L=300 MM	SCHLAUCH	HOSE	TUYAU
33	1	77590	SLANGE VINKEL 3/8"/VINKEL M18 L=800 MM	SCHLAUCH	HOSE	TUYAU