

DALBO®

**Reservedele
Spareparts
Ersatzteile
Pieces**

DINCO Classic
300/380/470
Serienr: 3400 -XXXX

MADE IN **D**ENMARK

Indholdsfortegnelse,

Table of Contents, Inhaltsverzeichnis, Table des matières

RESERVEDELSLISTENS OPBYGNING, THE CONSTRUCTION OF THE SPAREPARTSLIST,	3
DINCO	4
DINCO 300/380	4
DINCO 470	6
TAND MED SPRINGBOLT, TOOTH CPL. SHEAR BOLT, ZINKEN KOMPL., DENT CPL. BOUL	8
<i>Stilk dobbelt m. spindel kpl., Stiel doppelt, Double shank, Tige double</i>	<i>10</i>
<i>Nav t/skive kpl. Ø35, nabe, hub, moyeu</i>	<i>12</i>
PAKKER.....	14
T-RINGS EFTERLØBER, ROLLER, NACHLÄUFER, TRAIN	14
T-RINGE PÅ AKSEL, SHAFT RING SET, SATZ RINGE FÜR DEI ACHSE, ANNEAUX SUR ARBRE	16
T-RINGS EFTERLØBER, ROLLER, NACHLÄUFER, TRAIN	18
T-RINGE PÅ AKSEL, SHAFT RING SET, SATZ RINGE FÜR DEI ACHSE, ANNEAUX SUR ARBRE	20
RØRPAKKERVALSE, CAGE ROLLER, ROHRSTABWALZE, ROULEAU A TUBE	22
EKSTRAUDSTYR, OPTIONS.....	24
F-JERNS KRYMLER TIL T-RINGEEFTERLØBER, FLAT IRON CAGE ROLLER, F-EISEN KRÜMLER, ROULEAU DE NIVELLEMENT DE FER EN F	24
F-JERNS KRYMLER TIL RØRPAKKER, FLAT IRON CAGE ROLLER, F-EISEN KRÜMLER, ROULEAU DE NIVELLEMENT DE FER EN F	26
YDESKIVER KPL. 1 SÆT, SPECIEL, DISC, SCHEIBE, RONDELLE	28
TALLERKEN HØJRE/VENSTRE VINGE, OUTER DISC, SCHEIBE AUSSERST, RONDELLE LATERAL	30
HYDRAULIK.....	32
HYDRAULIK SAMMENKLAP 380/470	32

Reservedelslistens opbygning, the construction of the sparepartslist,

<p>Reservedelstegningerne tager udgangspunkt i en 3 meter DINCO. Ved de øvrige modeller er der udarbejdet en ekstra reservedelsliste hvor i forskellene som hoveddrummer mm. fremgår</p>	<p>The spare parts drawings have there point of origin in a 3 m DINCO. For the other models there is made an extra spare parts list, where the differences is shown.</p>	<p>Die Ersatzteilzeichnungen sind ursprünglich von der 3 m DINCO. Für die anderen Typen gibt es eine separate Ersatzteilliste, die Unterschiede aufzeigt.</p>	<p>Les dessins des pièces détachées sont basés sur un DINCO 3 m. Pour les autres modèles une liste supplémentaire de pièces est établie où les différences sont montrées.</p>
<p>For deres sikkerhed samt for funktionsdygtigheden af deres maskine, bør der kun anvendes originale DALBO reservedele til deres maskine</p>	<p>For your safety and for the functions of the mashing, you should only use original spare parts for m DALBO.</p>	<p>Zu Ihrer Sicherheit und zur einwandfreien Funktion ihres Gerätes sollten sie unbedingt nur original DALBO Ersatzteile verwenden.</p>	<p>Pour votre sécurité et pour les fonctions du matériel, vous devez utiliser uniquement des pièces détachées d'origine DALBO.</p>
<p>Når de bestiller reservedele bør de altid informere om:</p> <ul style="list-style-type: none"> • Reservedelsnummer • Maskinens typenummer • Antal styk af reservedelen 	<p>When you order spare parts, you should always inform about:</p> <ul style="list-style-type: none"> • Spare part number • The mashing type number • Amount of spare parts pieces 	<p>Wenn sie Ersatzteile bestellen bitte folgendes beachten:</p> <ul style="list-style-type: none"> • Ersatzteil-Nummer • Geräte-Nummer und -typ • Anzahl der Ersatzteile 	<p>Lorsque vous commandez vos pièces détachées, vous devez toujours nous indiquer :</p> <ul style="list-style-type: none"> • Le numéro de la pièce • Le type de la machine • La quantité des pièces détachées.

DINCO
DINCO 300/380

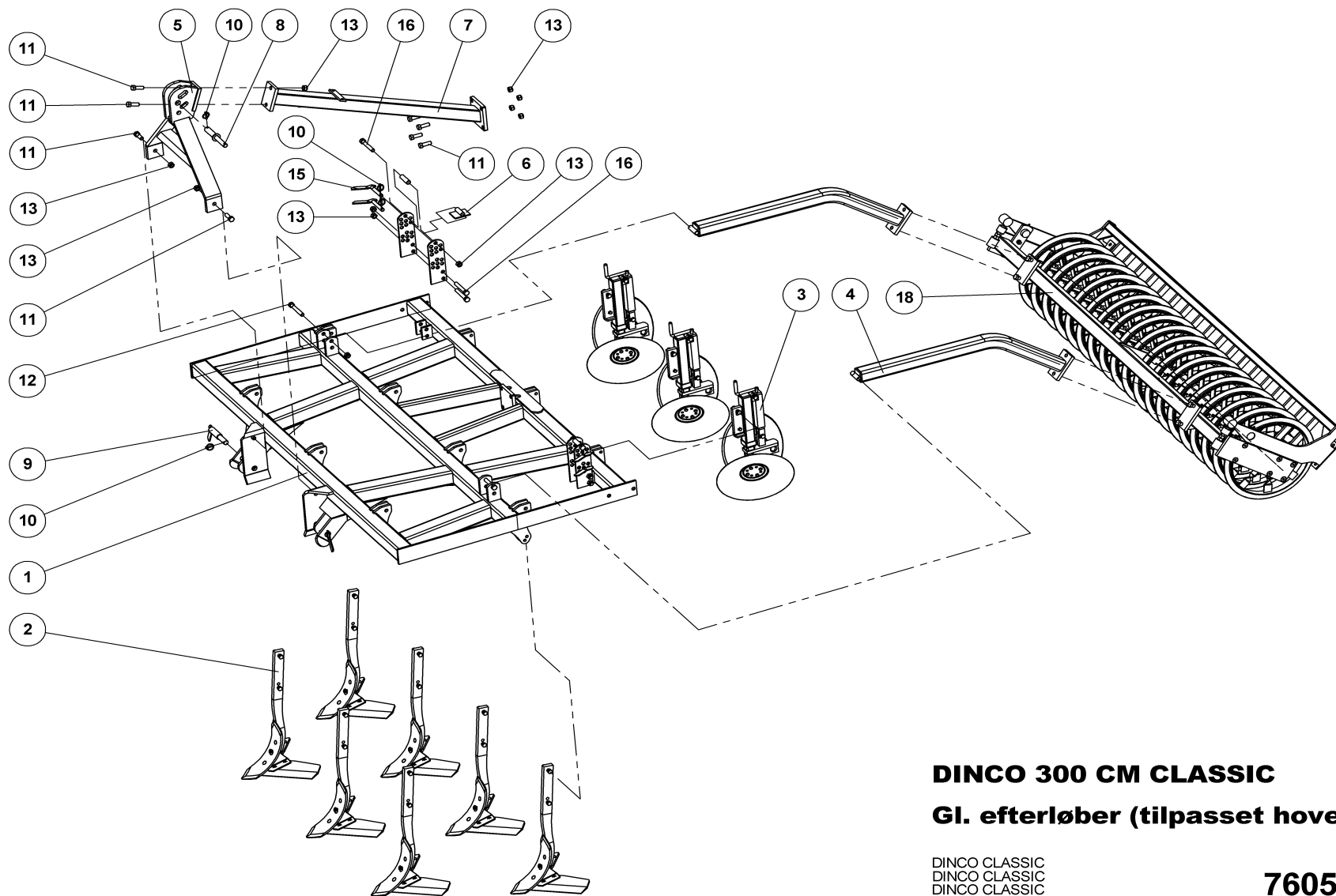

DINCO 300 CM CLASSIC
Gl. efterløber (tilpasset hovedramme)

DINCO CLASSIC
DINCO CLASSIC
DINCO CLASSIC

76052



DINCO 300 CM CLASSIC

Gl. efterløber (tilpasset hovedramme)

76052

DINCO CLASSIC
DINCO CLASSIC
DINCO CLASSIC

Pos.	Qty.	Part nr.	Benævnelse	Bezeichnung	Description	Designation
1	1	76324	HOVEDRAMME CLASSIC 300	HAUPTRAHMEN HYDR.	MAIN FRAME	CHASSIS HYDRAULIQUE
2	7	76241	TAND KPL. M. MS.	ZINKEN KOMPL.	TOOTH CPL SHEAR BOLT	DENT CPL. BOUL.
3	3	76290	STILK DOBBEL M. SPINDEL KPL. MODEL 2000	STIEL DOPPELT	DOUBLE SHANK	TIGE DOUBLE
4	2	80406	ARM TIL EFTERLØBER KPL.	ARM	ARM	BRAS
5	1	76363	LIFTOPHÆNG MODEL 2000	DREIPUNKT AUFHÄNGUNG	LINKAGE	SUSPENSION
6	2	76386	STØTTE FOR ARM	STÜTZE FÜR ARM	SUPPORT FOR ARM	BÉQUILLE POUR BRAS
7	1	76388	BAGSTIVER T/LIFTOPH., KORT 2004	HINTERE STANGE FÜR DIE LIFTAUFHÄNGUNG	REAR SUPPORT BAR FOR LINKAGE	BÂTON POUR SUSPENSION
8	1	90454	NAGLE U Ø25-32X105 KAT. II-III	BOLZEN	PIN	AXE
9	2	76454	NAGLE H Ø28/36,6X178(193)	AXE	PIN	BOLZEN
10	7	90680	RINGSPLIT Ø 8X40 FLAD	RINGSPLINT FLACH	LINCH PIN, FLAT	GOUPILLE PLATE
11	8	92334	BOLT 20x60 8.8 GALV.	SCHRAUBE	SCREW	BOULON
12	2	92340	BOLT 20x140 8.8 GALV.	SCHRAUBE	SCREW	BOULON
13	16	92052	MØTRIK M 20 SELVLÅS GALV. 8	MUTTER SELBSTGESICHERT	SELF-LOCKING NUT	ÉCROU DE SÉCURITÉ
14	4	75404	JUSTERPLADE KRYMLER, NY	JUSTIER PLATTE	ADJUSTING PLATE	PLAQUE AJUSTER
15	4	75505	NAGLE H Ø20X110(125)	AXE	PIN	BOLZEN
16	6	92341	BOLT 20x130 8.8 GALV.	SCHRAUBE	SCREW	BOULON
17	2	75406	Afstandsør til justerplade	ABSTANDSSTÜCK	SPACER	ENTRETOISE
18	1	76063	300 CM T-RINGS EFTERLØBER	T-RING WALZE	T-RING ROLLER	ROULEAU A T

DINCO 380 CM CLASSIC

76053

DINCO CLASSIC
DINCO CLASSIC
DINCO CLASSIC

Pos.	Qty.	Part nr.	Benævnelse	Bezeichnung	Description	Designation
1	1	76330	HOVEDRAMME CLASSIC 380	HAUPTRAHMEN	MAIN FRAME	CHASSIS
2	9	76241	TAND KPL M MS.	ZINKEN KOMPL.	TOOTH CPL. SHEAR BOLT	DENT CPL. BOUL
7	1	76359	BAGSTIVER T/LIFTOPH., KORT 2004	HINTERE STANGE FÜR DIE LIFTAUFHÄNGUNG	REAR SUPPORT BAR FOR LINKAGE	BATON POUR SUSPENSION
18	1	76065	3801 CM T-RINGS EFTERLØBER	T-RING WALZE	T-RING ROLLER	ROULEAU AT

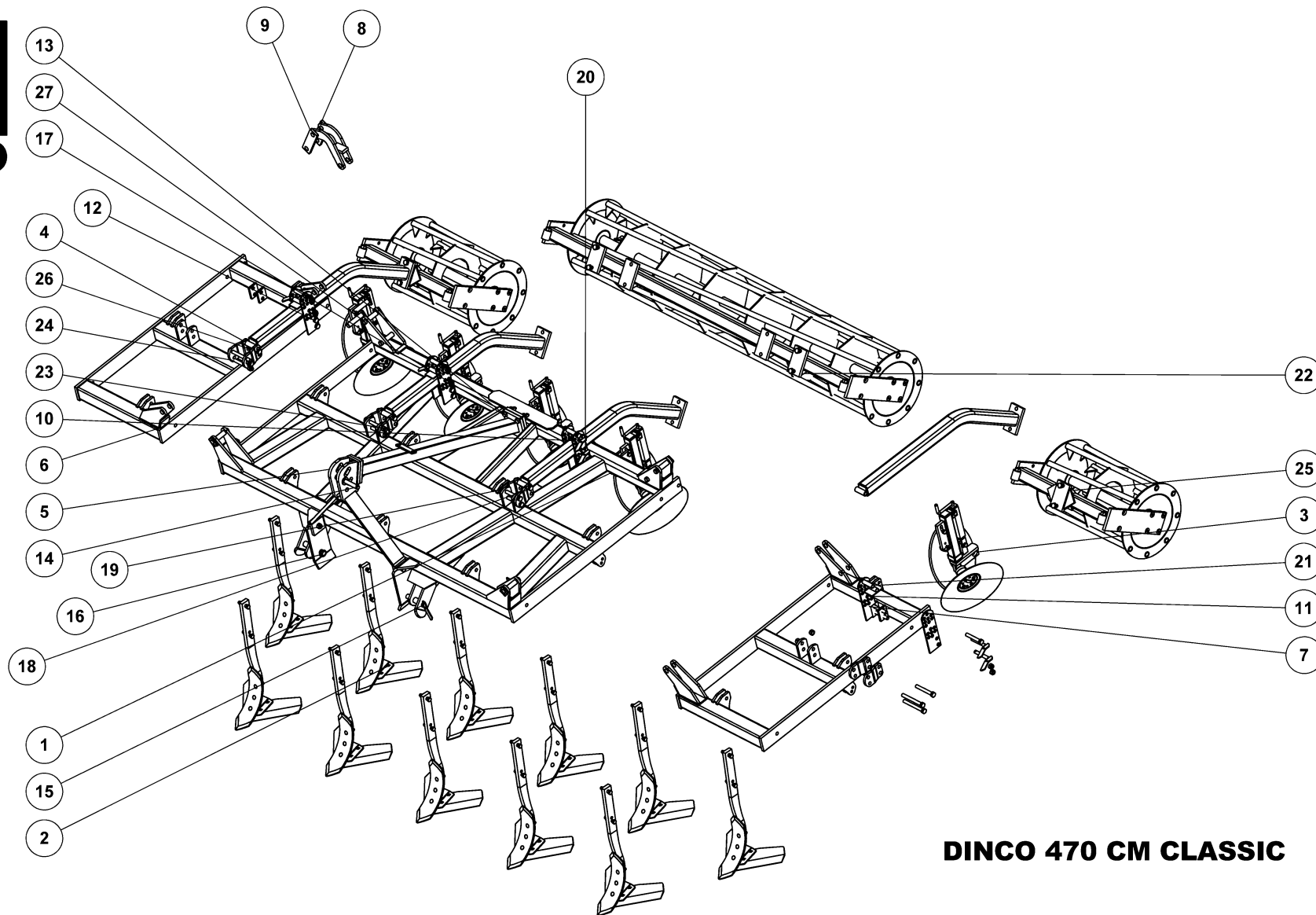

DINCO 470 CM CLASSIC

76054



DINCO 470 CM CLASSIC

76054

Pos.	Qty.	Part nr.	Benævnelse	Bezeichnung	Description	Designation
1	1	76325	HOVEDRAMME CLASSIC 470 HYDR.	HAUPTRAHMEN HYDR.	MAIN FRAME	CHASSIS HYDRAULIQUE
2	11	76241	TAND KPL. M. MS.	ZINKEN KOMPL.	TOOTH CPL SHEAR BOLT	DENT CPL BOUL.
3	7	76290	STILK DOBBEL M. SPINDEL KPL. MODEL 2000	STIEL DOPPELT	DOUBLE SHANK	TIGE DOUBLE
4	4	80406	ARM TIL EFTERLØBER KPL.	ARM	ARM	BRAS
5	1	76363	LIFTOPHÆNG MODEL 2000	DREIPUNKT AUFHÄNGUNG	LINKAGE	SUSPENSION
6	1	76338	SIDERAMME 470 H 2004	SEITENRAHMEN RECHTS	SIDE FRAME, RIGHT	CADRE LATÉRAL DROITE
7	1	76339	SIDERAMME 470 V 2004	SEITENRAHMEN LINKS MODELL 2000	SIDE FRAME, LEFT	CADRE LATÉRAL GAUCHE
8	1	76421	VIPPEARM TIL SIDESEKTION	WIPPARM	ROCKER ARM	BRAS BASCULANTS
9	2	76418	FORBINDELSARM TIL CYLINDER	VERBINDUNGSARME FÜR ZYLINDER	CONNECTING ARM FOR CYLINDER	BRAS DE CONNEXION POUR CYLINDRE
10	10	75404	JUSTERPLADE KRYMLER, NY	JUSTIER PLATTE	ADJUSTING PLATE	PLAQUE AJUSTER
11	4	76386	STØTTE FOR ARM	STÜTZE FÜR ARM	SUPPORT FOR ARM	BEQUILLE POUR BRAS
12	14	92341	BOLT 20x130 8.8 GALV.	SCHRAUBE	SCREW	BOULON
13	2	76388	BAGSTIVER T/LIFTOPH., KORT 2004	HINTERE STANGE FÜR DIE LIFTAUFHÄNGUNG	REAR SUPPORT BAR FOR LINKAGE	BÂTON POUR SUSPENSION
14	1	90454	NAGLE U Ø25-32X105 KAT. II-III	BOLZEN	PIN	AXE
15	2	76454	NAGLE H Ø28/35X178(193)	BOLZEN	PIN	AXE
16	11	90680	RINGSPLIT Ø 8X40 FLAD	RINGSPLINT	LINCH PIN	GOUPILLE
17	8	92334	BOLT 20x60 8.8 GALV.	SCHRAUBE	SCREW	BOULON
18	1	92340	BOLT 20x140 8.8 GALV.	SCHRAUBE	SCREW	BOULON
19	32	92052	MØTRIK M 20 SELVLÅS. GALV. 8	MUTTER SELBSTGESICHERT	SELF-LOCKING NUT	ÉCROU DE SÉCURITÉ
20	8	75505	NAGLE H Ø20X110(125)	BOLZEN	PIN	AXE
21	4	75406	AFSTANDSRØR TIL JUSTERPLADE	ABSTANDSSTÜCK	SPACER	ENTRETOISE
22	1	76068	470+560 RØRPAKKER-EFTERLØBER	ROHRSTABWALZE	CAGE ROLLER	ROULEAU A TUBE
23	4	76485	KONVERTER TIL CLASSIC	HALTER	BRACKET	SUPPORT
24	8	92339	BOLT 20x180 8.8 GALV.	SCHRAUBE	SCREW	BOULON
25	2	76070	380+470 SIDE. RØRPAKKER-EFTERLØBER	ROHRSTABWALZE	CAGE ROLLER	ROULEAU A TUBE
26	3	92338	BOLT 20x150 8.8 GALV.	SCHRAUBE	SCREW	BOULON
27	8	76451	NAGLE F Ø30X115(143)	BOLZEN	PIN	AXE

Tand med springbolt, tooth cpl. shear bolt, Zinken kompl., dent cpl. boul

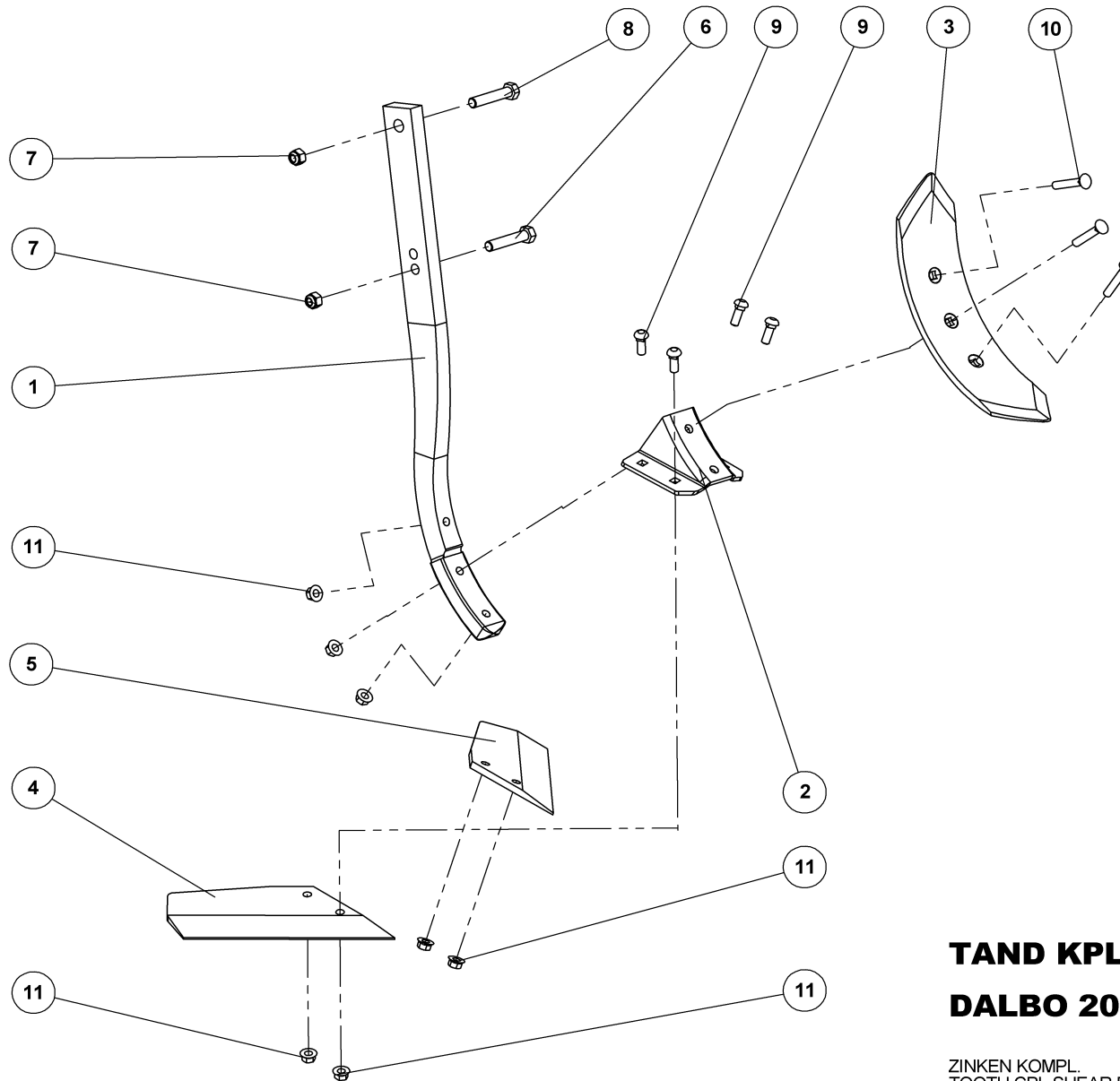

TAND KPL. M. MS.
DALBO 2004 CLASSIC

ZINKEN KOMPL.
TOOTH CPL SHEAR BOLT
DENT CPL BOUL.

76241

Side 8



TAND KPL. M. MS.

ZINKEN KOMPL.
TOOTH CPL SHEAR BOLT
DENT CPL BOUL.

DALBO 2004 CLASSIC

76241

Pos.	Qty.	Part nr.	Benævnelse	Bezeichnung	Description	Designation
1	1	76250	STIELE 60X25 - DAL-BO 2000	STIELE	HANDLE	TIGE
2	1	76252	VINGEKONSOL 8MM - DAL-BO 2000	SCHAR KONSOLE	WING CONSOLE	CONSOLE D'AILE
3	1	76261	STUBSPIDS LIGE 120X10 - DAL-BO 200	SPITZE	POINT, STRAIGHT	POINTE RIGIDE DROITE
4	1	76264	VINGESKÆR HØJRE - DAL-BO 2000	FLÜGELSCHAR RECHTS	WING PLOUGHSHARE, RIGHT	SOC À AILES LONGUES DROITE
5	1	76263	VINGESKÆR VENSTRE - DAL-BO 2000	FLÜGELSCHAR LINKS	WING PLOUGHSHARE, LEFT	SOC À AILES LONGUES GAUCHE
6	1	92800	BOLT 16X80 KVAL. 4.6 GALV.	SCHRAUBE	SCREW	BOULON
7	2	92051	MØTRIK M16 SELVLÅS. GLV.8	MUTTER	SELF-LOCKING NUT	ÉCROU
8	1	92320	BOLT 16x80 8.8 GALV.	SCHRAUBE	SCREW	BOULON
9	4	92737	BOLT 12X35 10.9 (BRÆDDEBOLT)	SCHRAUBE (BRETTSCHRAUBE)	BOARD BOLT	BOULON
10	3	75265	PLOVBOLT M12X70 10.9	BOLZEN 10.9 (PFLUG)	PLOW BOLT	BOULON 10.9
11	7	92520	MØTRIK M12 - FLANGE 10 (SIKRINGSMØTRIK)	MUTTER	LOCK NUT	ÉCROU

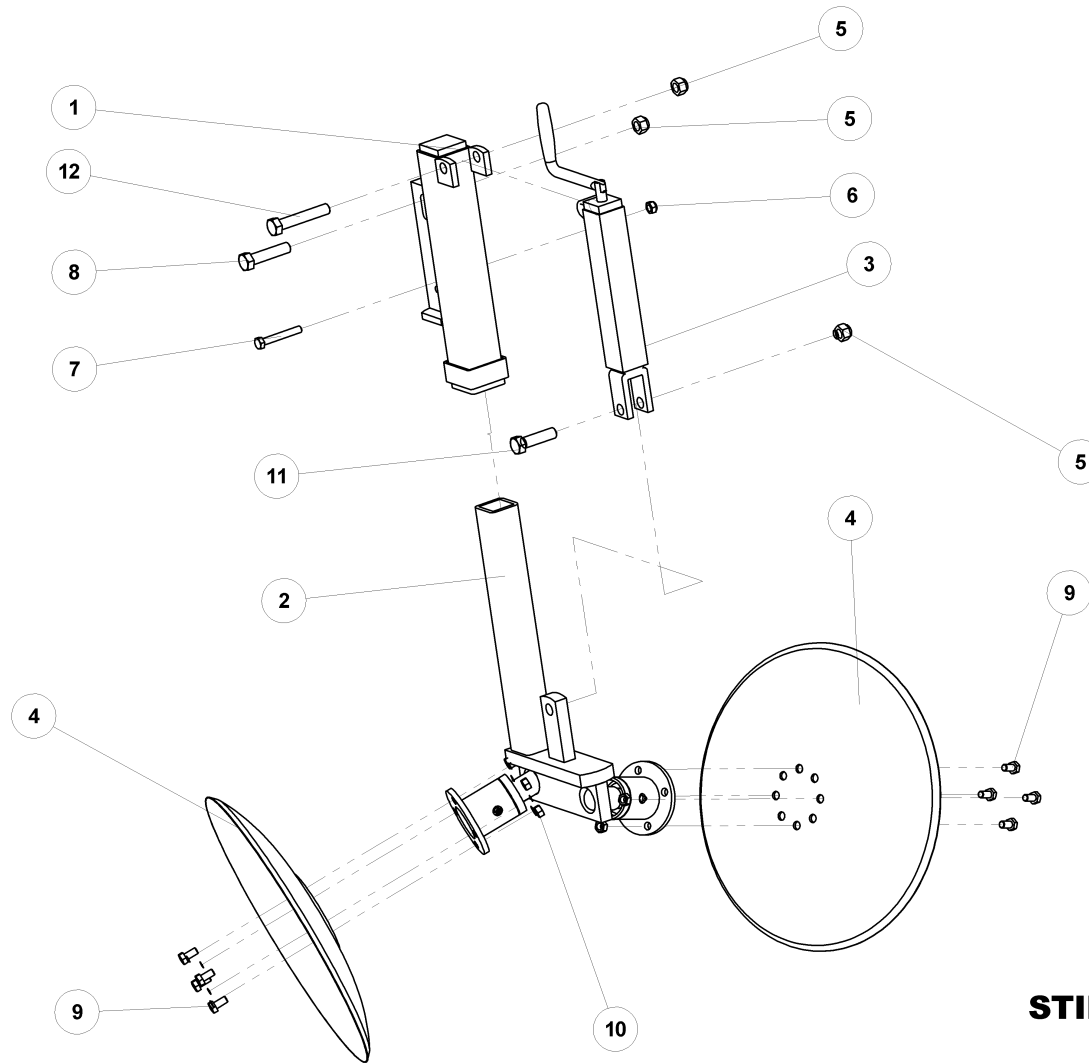

STILK DOBBEL M. SPINDEL KPL.

STIEL DOPPELT
DOUBLE SHANK
TIGE DOUBLE



STILK DOBBEL M. SPINDEL KPL. MODEL 200

76290

STIEL DOPPELT
DOUBLE SHANK
TIGE DOUBLE

Pos.	Qty.	Part nr.	Benævnelse	Bezeichnung	Description	Designation
1	1	76407	STILK HOLDER MODEL 2000	STIEL HALTER	SHANK MOUNT	SUPPORT DE TIGE
2	1	76495	STILK DOBBELT KPL. Ø35	STIEL DOPPELT	DOUBLE SHANK	TIGE DOUBLE
3	1	21465	SPINDEL SHF 6-01	SPINDEL	SPINDLE	FUSEAU
4	2	75261	TALLERKEN Ø460x4 GLAT	SCHEIBE	DISC	RONDELLE
5	3	92051	MØTRIK M16 SELVLÅS. GLV.8	MUTTER	SELF-LOCKING NUT	ÉCROU
6	1	92049	MØTRIK M10 SELVLÅS. GLV.8	MUTTER	SELF-LOCKING NUT	ÉCROU
7	1	92278	BOLT 10X 70 8.8 GLV.	SCHRAUBE	SCREW	BOULON
8	1	92319	BOLT 16x70 8.8 GALV.	SCHRAUBE	SCREW	BOULON
9	8	92273	BOLT 10x20 8.8 GALV. (SÆTBOLT)	SCHRAUBE	SET SCREW	BOULON
10	8	92029	MØTRIK M10 GALV. KI.8	MUTTER	NUT	ÉCROU
11	1	92318	BOLT 16x60 8.8 GALV.	SCHRAUBE	SCREW	BOULON
12	1	92321	BOLT 16x90 8.8 GALV.	SCHRAUBE	SCREW	BOULON

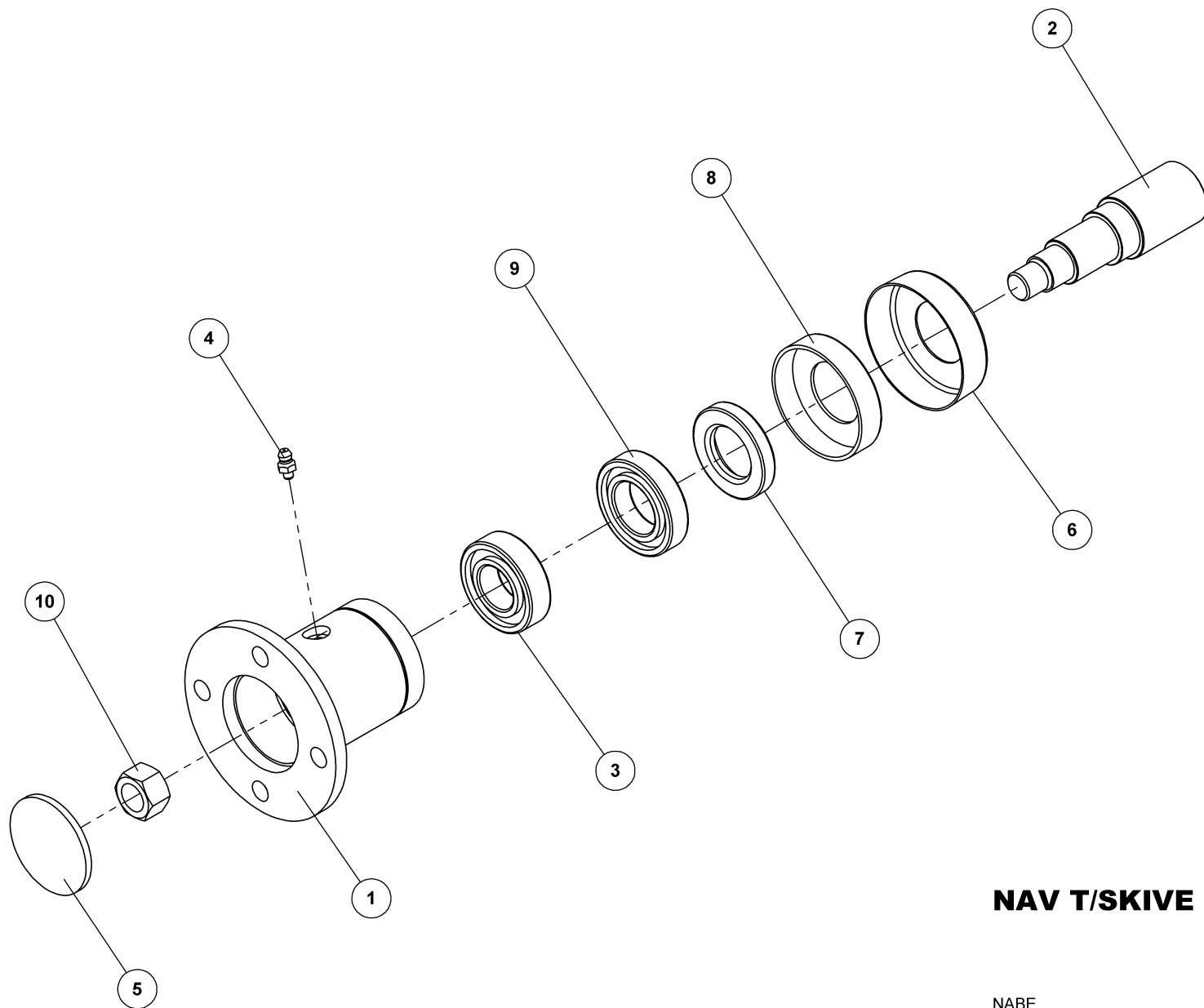

NAV T/SKIVE KPL. Ø35

NABE
HUB
MOYEU DE RONDELLE CPL.

76885



NAV T/SKIVE KPL. Ø35

76885

NABE
HUB
MOYEU DE RONDELLE CPL.

Pos.	Qty.	Part nr.	Benævnelse	Bezeichnung	Description	Designation
1	1	76887	NAVHUS TIL Ø35 AKSEL	NABEGEHÄUSE	HUB HOUSING	BOÎTE DE MOYEU
2	1	76888	AKSEL Ø35X121 TIL NAV	ACHSE	SHAFT	ARBRE
3	1	75272	KUGLELEJE 6205	LAGER	BEARING	FIXATION
4	1	75889	SMØRENIPPEL M6X1 K	SCHMIERNIPPEL	GREASE NIPPLE	GRAISSEUR
5	1	75891	GUMMISKIVE T/NAV 55,5x4	GUMMISCHEIBE	RUBBER WASHER FOR HUB	RONDELLE EN CAOUTCHOUC POUR MOYEU
6	1	76886	STØVKAPPE M. Ø35 MM HUL - STÅL	STAUBKAPPE FÜR NABE - STAHL	DUST CAP FOR HUB, STEEL	CACHE-POUSSIÈRE POUR MOYEU - ACIER
7	1	76890	TÆTNINGSRING 55/35/10 T/NAV	DICHTUNGSRING	SEAL	BAGUE D'ÉTANCHÉITÉ
8	1	76892	STØVKAPPE T/NAV PLAST	STAUBKAPPE FÜR NABE - PLASTIK	DUST CAP FOR HUB, PLASTIC	CACHE-POUSSIÈRE POUR MOYEU - PLASTIQUE
9	1	75273	KUGLELEJE 6006	LAGER	BEARING	FIXATION
10	1	92031	MØTRIK M16 GALV. kl.8	MUTTER	NUT	ÉCROU

Pakker

T-rings efterløber, roller, nachläufer, train

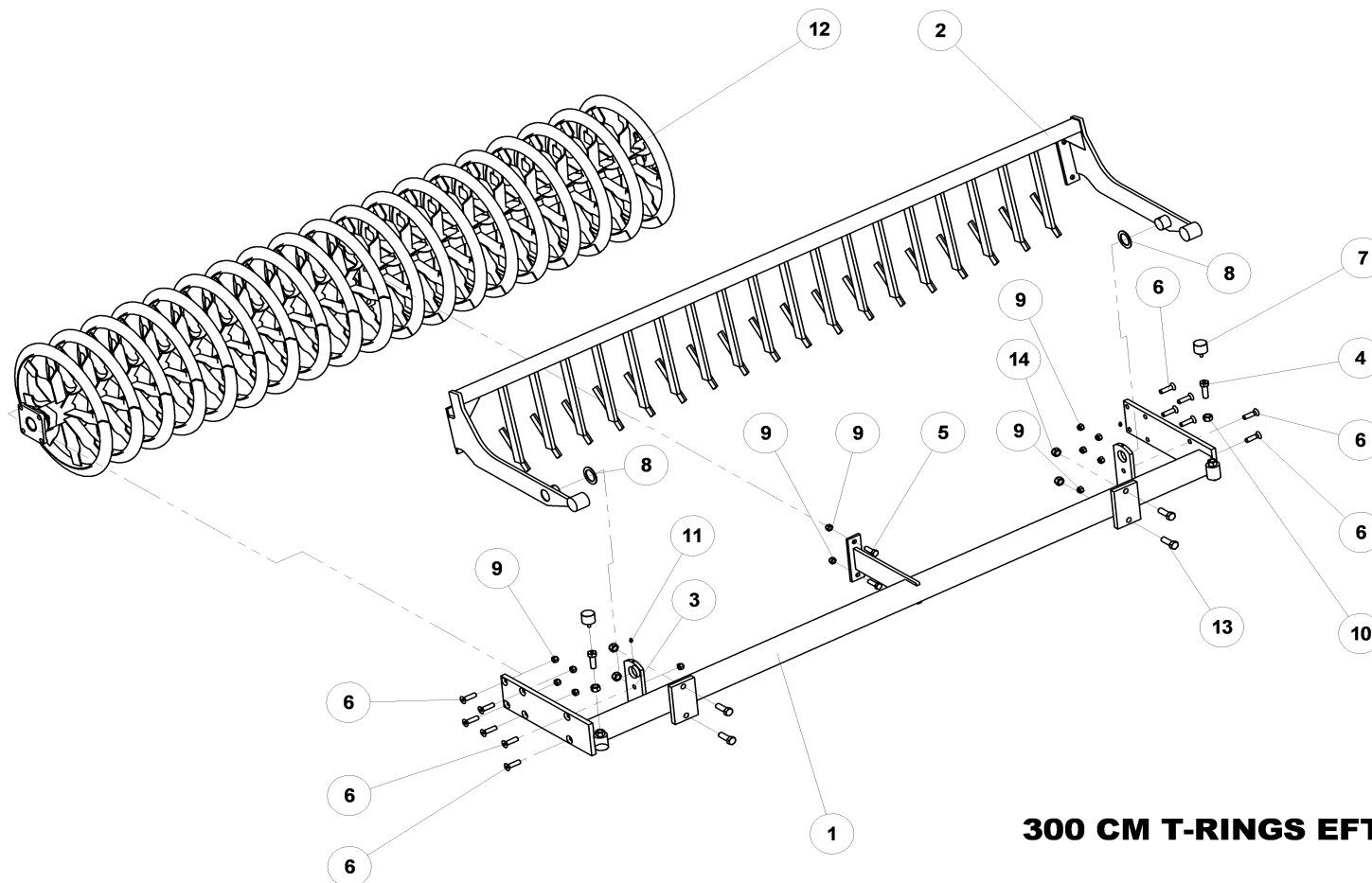

300 CM T-RINGS EFTERLØBER

2930



300 CM T-RINGS EFTERLØBER

2930

Pos.	Qty.	Part nr.	Benævnelse	Bezeichnung	Description	Designation
1	1	76271	T-RINGS RAMME 300CM	T-RING RAHMEN	T-RING FRAME	CHASSIS D'ANNEAU-T
2	1	76281	AFSKRABER BOM TIL 300CM	BARRE DU SYSTÈME DE RACLAGE	SCRAPER GANG FOR 300CM	ABSTREIFER-BALKEN
3	2	76475	BOLTEFÆST. T/F-JERNS KRYMLER	BEFESTIGUNG	BOLTED PLATE FOR F-IRON CAGE ROLLER	FIXATION DE BOULON POUR ROULEAU DE FER EN F
4	2	76476	BOLT T/GUMMIKLODS JUSTERING	SCHRAUBE	RUBBER BLOCK ADJUSTMENT SCREW	BOULON
5	2	92317	BOLT 16x50 8.8 GALV. (SÆTBOLT)	SCHRAUBE	SET SCREW	BOULON
6	12	92420	BOLT 16x60 GALV. 8.8 UNDERSÆNKET	SCHRAUBE	COUNTERSUNK SCREW	BOULON
7	2	85375	GUMMIKLODS	GUMMIKLOTZ	RUBBER BLOCK	BLOC EN CAOUTCHOUC
8	2	51349	SKIVE Ø51-Ø75-3 Giv	SCHEIBE	WASHER	RONDELLE
9	14	92051	MØTRIK M16 SELVLÅS. GLV.8	MUTTER	SELF-LOCKING NUT	ÉCROU
10	2	92032	MØTRIK M20 GALV. kl.8	MUTTER	NUT	ÉCROU
11	2	90721	SMØRENIPPEL M8x1	SCHMIERNIPPEL	GREASE NIPPLE	GRAISSEUR
12	1	76220	T-RING PÅ AKSEL, 300			
13	4	92334	BOLT 20x60 8.8 GALV.	BOLZEN		BOULON
14	4	92052	MØTRIK M 20 SELVLÅS. GALV. 8	MUTTER SELBSTGESICHERT	SELF-LOCKING NUT	ÉCROU DE SÉCURITÉ

380 CM T-RINGS EFTERLØBER

76065

DINCO CLASSIC
DINCO CLASSIC
DINCO CLASSIC

Pos.	Qty.	Part nr.	Benævnelse	Bezeichnung	Description	Designation
1	1	76272	T-RINGS RAMME 380 CM	T-RING RAHMEN	T-RING FRAME	CHASSIS D'ANNEAU-T
2	1	76282	AFSKRABER BOM TIL 380 CM	ABSTREIFER BALKEN	SCRAPER GANG FOR 380 CM	BARRE DU SYSTEME DE RACLAGE
12	1	76221	T-RING PÅ AKSEL 380 CM	T-RING WALZE	T-RING ROLLER	ROULEAU-T

T-ringe på aksel, Shaft ring set, Satz ringe für die achse, anneaux sur arbre

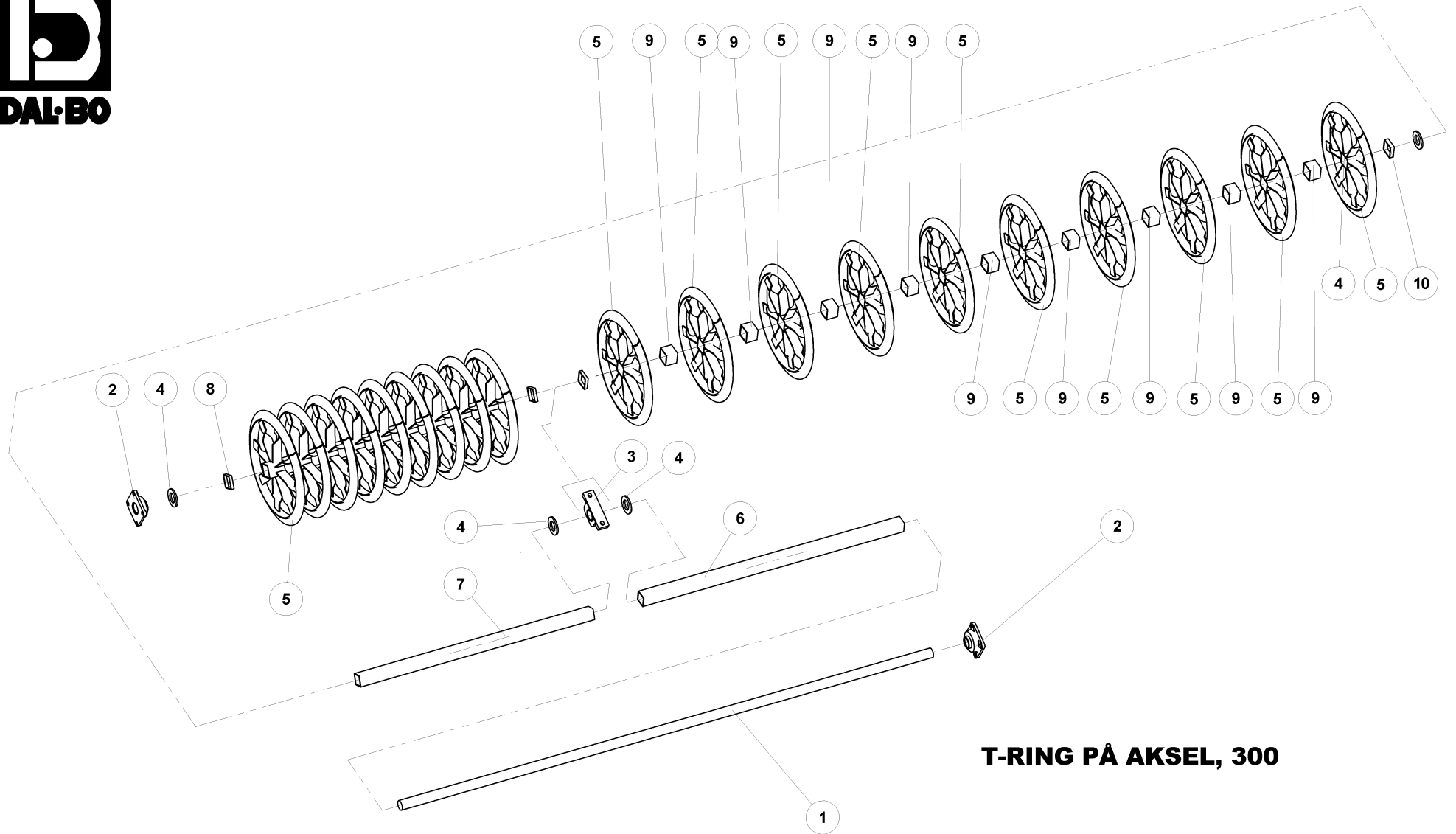

T-RING PÅ AKSEL, 300

SATZ RINGE FÜR DIE ACHSE
SHAFT RING SET
ANNEAUX SUR ARBRE

76220



T-RING PÅ AKSEL, 300

76220

SATZ RINGE FÜR DIE ACHSE
SHAFT RING SET
ANNEAUX SUR ARBRE

Pos.	Qty.	Part nr.	Benævnelse	Bezeichnung	Description	Designation
1	1	76465	AKSEL Ø 50 X 2965	ARBRE	SHAFT	ACHSE
2	2	12391	KOMPLET Y-LEJE FY 50 TL	KOMPLETTES Y-LAGER	COMPLETE Y-BEARING	PALIER-Y COMPLET
3	1	12390	KOMPLET Y-LEJE SY 50 TL	KOMPLETTES Y-LAGER	COMPLETE Y-BEARING	PALIER-Y COMPLET
4	4	90674	SKIVE Ø52-Ø92-8	UNTERLEGSCHIEBE	WASHER	RONDELLE DE SERRAGE
5	19	90875	T-RING Ø600MM. M. FIRK.-NAV 89 MM	T-RINGE	T-RING	ANNEAU-T
6	1	93025145590L90LX	FIRK-RØR 60X60X4-1455 ST. 44.2	VIERKANT ROHR	SQUARE TUBE	TUBE CARRÉ
7	1	93025130590L90LX	FIRK-RØR 60X60X4-1305 ST. 44.2	VIERKANT ROHR	SQUARE TUBE	TUBE CARRÉ
8	3	93030001590L90LX	FIRKANT-RØR 70X70X4-15	VIERKANT ROHR	SQUARE TUBE	TUBE CARRÉ
9	17	93030006090L90LX	FIRK-RØR 70X70X4-60 ST. 44.2	VIERKANT ROHR	SQUARE TUBE	TUBE CARRÉ
10	1	93030002090L90LX	FIRKANT-RØR 70X70X4-20	VIERKANT ROHR	SQUARE TUBE	TUBE CARRÉ

T-RINGE PÅ AKSEL, 380

76065

SATZ RINGE FÜR DIE ACHSE
SHAFT RING SET
ANNEAUX SUR ARBRE

Pos.	Qty.	Part nr.	Benævnelse	Bezeichnung	Description	Designation
1	1	76466	AKSEL Ø 50 X 3850 MM	ACHSE	SHAFT	ARBRE
5	25	90875	T-RING Ø600 MM M FIRK.-NAV 89 MM	T-RINGE	T-RING	ANNEAU-T

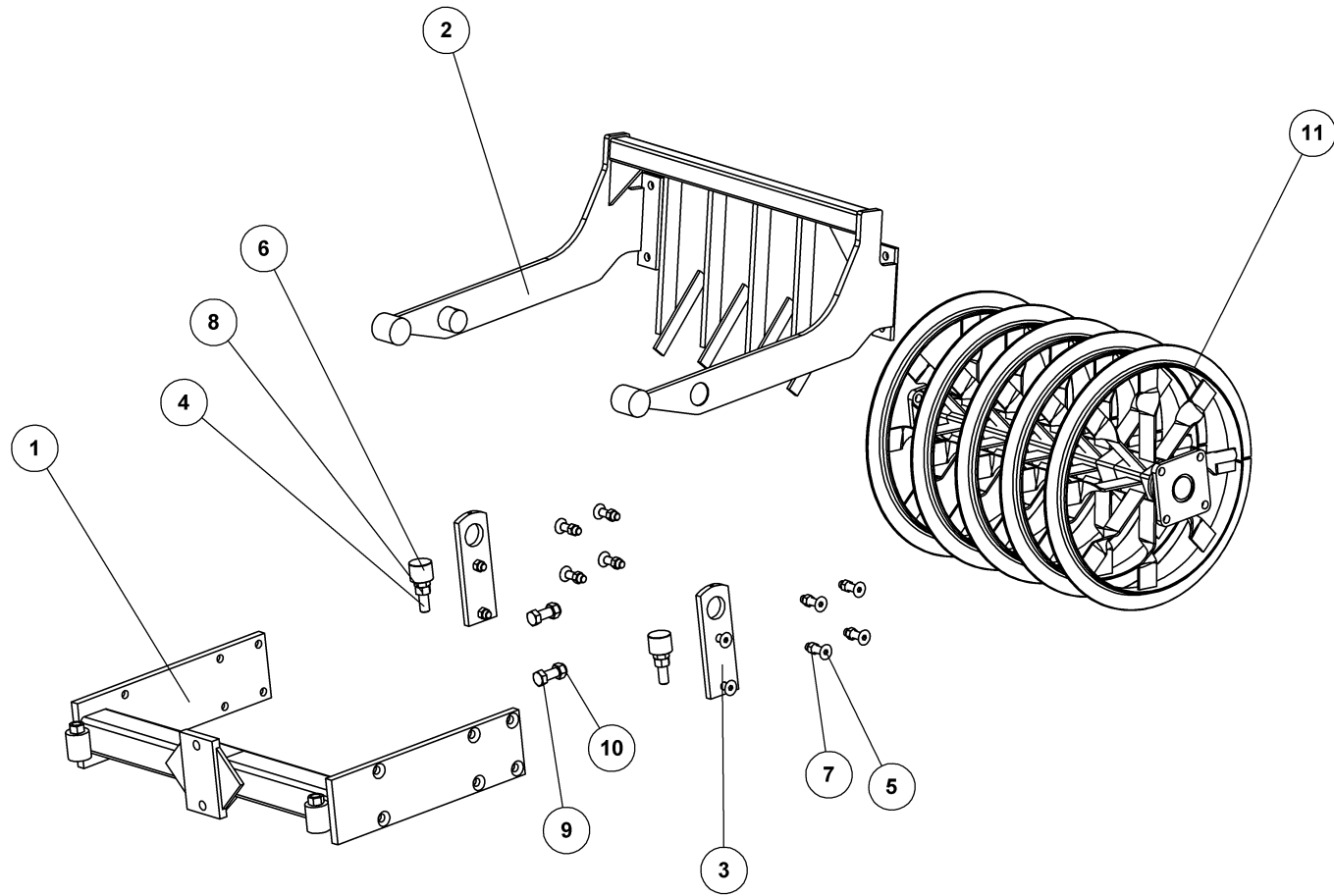

380/470 CM SIDE T-RINGS EFTERLØ

3400

76071



380/470 CM SIDE T-RINGS EFTERLØBER

76071

3400

Pos.	Qty.	Part nr.	Benævnelse	Bezeichnung	Description	Designation
1	1	76345	SIDEKRYMLERRAMME - 380 + 470 CM HYDR.	CADRE DE ROULEAU LATÉRAL HYDR.	HYDR_CAGE ROLLER_SIDE_FRAME	SEITEKRÜMLERRAHMEN HYDR.
2	1	76285	AESKRABER BOM SIDE 380+470CM	BARRE DU SYSTÈME DE RACLAGE CÔTÉ	SCRAPER GANG_SIDE	ABSTREIFER-BALKEN
3	2	76475	BOLTEFÆST. T/F-JERNS KRYMLER	BEFESTIGUNG	BOLTED PLATE FOR F-IRON CAGE ROLLER	FIXATION DE BOULON POUR ROULEAU DE FER EN F
4	2	76476	BOLT T/GUMMIKLODS JUSTERING	SCHRAUBE	RUBBER BLOCK ADJUSTMENT SCREW	BOULON
5	12	92420	BOLT 16x60 GALV. 8.8 UNDERSÆNKET	SCHRAUBE	COUNTERSUNK SCREW	BOULON
6	2	85375	GUMMIKLODS	GUMMIKLOTZ	RUBBER BLOCK	BLOC EN CAOUTCHOUC
7	12	92051	MØTRIK M16 SELVLÅS_GLV.8	MUTTER	SELF-LOCKING NUT	ÉCROU
8	2	92032	MØTRIK M20_GALV. kl.8	MUTTER	NUT	ÉCROU
9	2	92334	BOLT 20x60 8.8 GALV.	SCHRAUBE	SCREW	BOULON
10	2	92052	MØTRIK M 20 SELVLÅS_GALV. 8	MUTTER SELBSTGESICHERT	SELF-LOCKING NUT	ÉCROU DE SÉCURITÉ
11	1	76224	T-RINGE PÅ AKSEL, SIDE 380/470	SATZ RINGE FÜR DIE ACHSE	SHAFT RING SET	ANNEAUX SUR ARBRE

T-ringe på aksel, Shaft ring set, Satz ringe für die achse, anneaux sur arbre

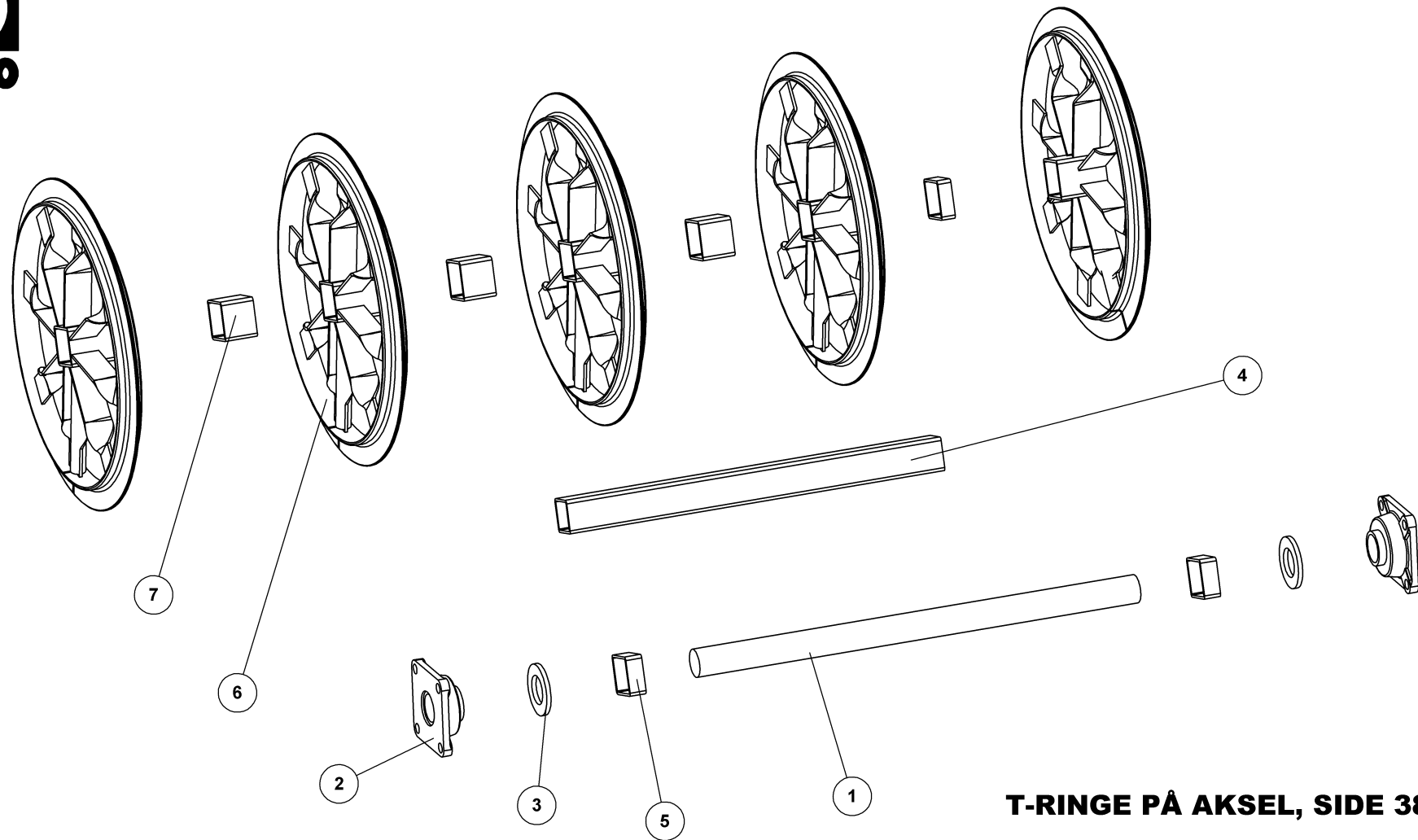

T-RINGE PÅ AKSEL, SIDE 380/470

SATZ RINGE FÜR DIE ACHSE
SHAFT RING SET
ANNEAUX SUR ARBRE

76224



T-RINGE PÅ AKSEL, SIDE 380/470

76224

SATZ RINGE FÜR DIE ACHSE
SHAFT RING SET
ANNEAUX SUR ARBRE

Pos.	Qty.	Part nr.	Benævnelse	Bezeichnung	Description	Designation
1	1	76460	AKSEL Ø50 X 830	ARBRE	SHAFT	ACHSE
2	2	12391	KOMPLET Y-LEJE FY 50 TL	KOMPLETTES Y-LAGER	COMPLETE Y-BEARING	PALIER-Y COMPLET
3	2	90674	SKIVE Ø52-Ø92-8	UNTERLEGSCHEIBE	WASHER	RONDELLE DE SERRAGE
4	1	93025070590L90LX	FIRK-RØR 60X60X4-705 ST. 44.2	VIERKANT ROHR	SQUARE TUBE	TUBE CARRÉ
5	2	93030003090L90LX	FIRK-RØR 70X70X4-30 ST. 44.2	VIERKANT ROHR	SQUARE TUBE	TUBE CARRÉ
6	5	90875	T-RING Ø600MM. M. FIRK. -NAV 89 MM	T-RINGE	T-RING	ANNEAU-T
7	3	93030006090L90LX	FIRK-RØR 70X70X4-60 ST. 44.2	VIERKANT ROHR	SQARE TUBE	TUBE CARRÉ
8	1	93030002590L90LX	FIRKANT-RØR 70X70X4-25	VIERKANT ROHR	SQUARE TUBE	TUBE CARRÉ

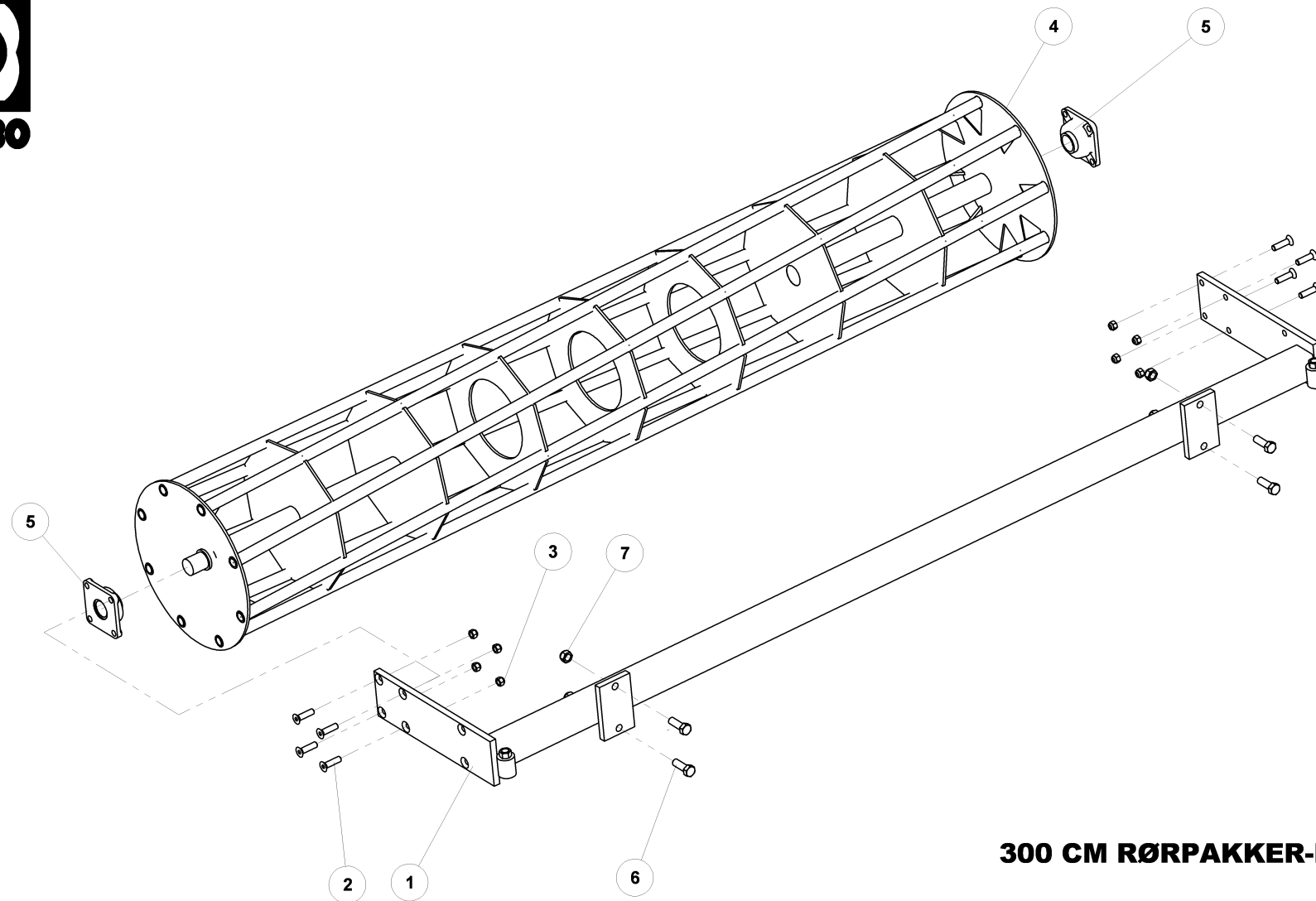

300 CM RØRPAKKER-EFTERLØBER

2930



300 CM RØRPAKKER-EFTERLØBER

NACHLÄUFER
ROLLER
TRAÎNE

2930

Pos.	Qty.	Part nr.	Benævnelse	Bezeichnung	Description	Designation
1	1	75368	KRYMLERRAMME 300 CM	KRÜMLERRAHMEN	CAGE ROLLER	CADRE DE ROULEAU DE NIVELLEMENT
2	8	92420	BOLT 10x60 GALV. 8.8 UNDERSÆNKET	SCHRAUBE	COUNTERSUNK SCREW	BOULON
3	8	92051	MØTRIK M16 SELVLÅS. GLV.8	MUTTER	SELF-LOCKING NUT	ÉCROU
4	1	75380	KRYMLER - 300CM	KRÜMLER	CAGE ROLLER	ROULEAU DE NIVELLEMENT
5	2	12391	KOMPLET Y-LEJE FY 50 TL	KOMPLETTES Y-LAGER	COMPLETE Y-BEARING	PALIER-Y COMPLET
6	4	92334	BOLT 20x60 8.8 GALV.	SCHRAUBE	SCREW	BOULON
7	4	92052	MØTRIK M 20 SELVLÅS. GALV. 8	MUTTER SELBSTGESICHERT	SELF-LOCKING NUT	ÉCROU DE SÉCURITÉ

380 CM RØRPAKKER-EFTERLØBER

NACHLÄUFER
ROLLER
TRAÎNE

76064

Pos.	Qty.	Part nr.	Benævnelse	Bezeichnung	Description	Designation
1	1	76342	KRYMLERRAMME 380 CM	KRÜMLERRAHMEN	CAGE ROLLER	CADRE DE ROULEAU DE NIVELLEMENT
4	1	75382	KRYMLER 380 CM	KRÜMLER	CAGE ROLLER	ROULEAU DE NIVELLEMENT

470 CM RØRPAKKER-EFTERLØBER

Pos.	Qty.	Part nr.	Benævnelse	Bezeichnung	Description	Designation
1	1	76343	KRYMLERRAMME 470 CM	KRÜMLERRAHMEN	CAGE ROLLER FRAME	CADRE DE ROULEAU DE NIVELLEMENT
1	2	76345	KRYMLERRAMME 470CM, SIDE	KRÜMLERRAHMEN SEITE	CAGE ROLLER FRAME, SIDE	CADRE DE ROULEAU DE NIVELLEMENT
4	1	75392	KRYMLER 470 CM	KRÜMLER	CAGE ROLLER	ROULEAU DE NIVELLEMENT
4	2	75402	KRYMLER 470 CM, SIDE	KRÜMLER, SEITE	CAGE ROLLER, SIDE	ROULEAU DE NIVELLEMENT

Ekstraudstyr, options

F-jerns krymler til T-ringefterløber, flat iron cage roller, f-eisen krümler, rouleau de nivellement de fer en f

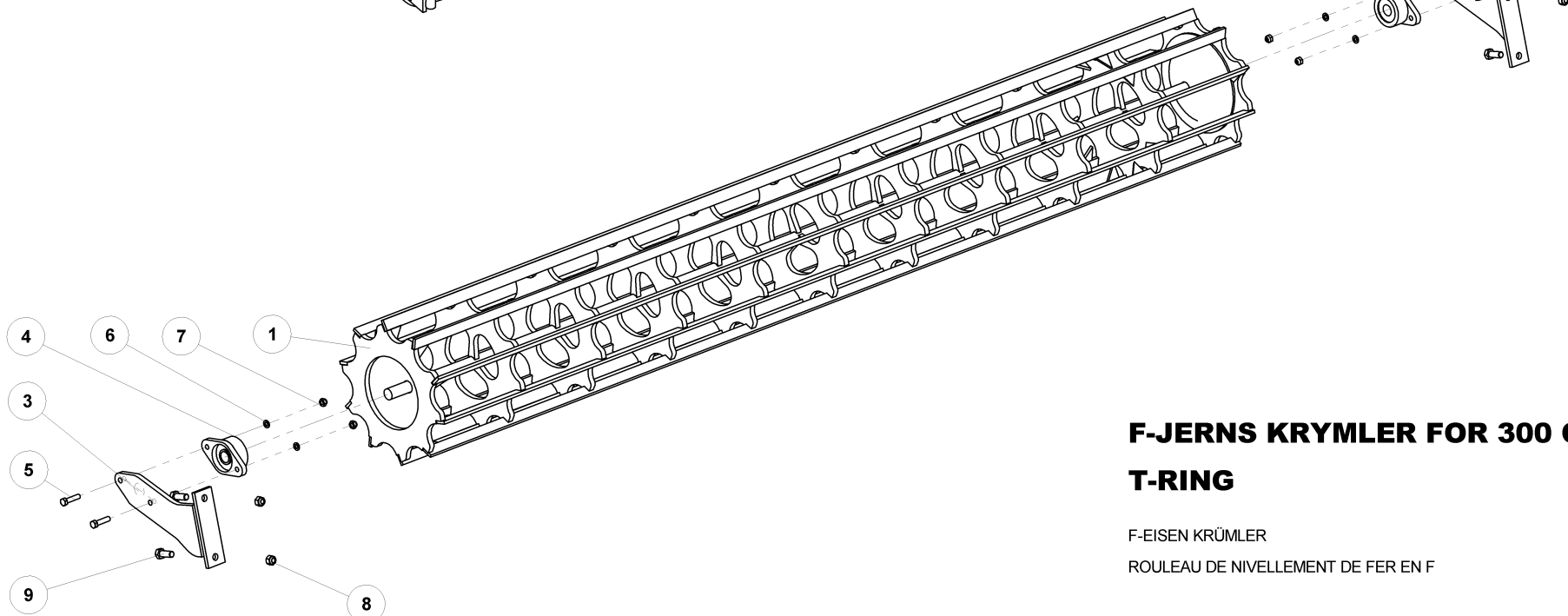
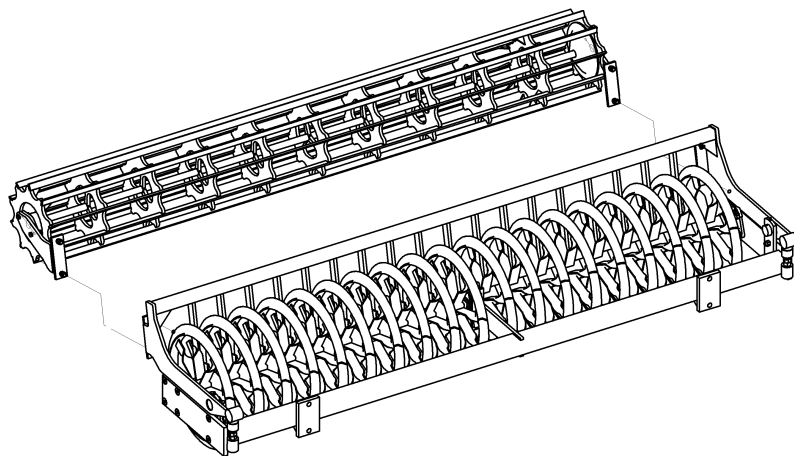

F-JERNS KRYMLER FOR 300 CM T-RING

F-EISEN KRÜMLER
ROULEAU DE NIVELLEMENT DE FER EN F



F-JERNS KRYMLER FOR 300 CM

T-RING

F-EISEN KRÜMLER

ROULEAU DE NIVELLEMENT DE FER EN F

Pos.	Qty.	Part nr.	Benævnelse	Bezeichnung	Description	Designation
1	1	76367	F-JERNS KRYMLER 300CM	ROULEAU DE NIVELLEMENT DE FER EN F	F-IRON CAGE ROLLER	F-EISEN KRÜMLER
2	1	76287	LEJEPLADE TIL F-JERNS KRYMLER VENSTRE	LAGERPLATTE FÜR F-EISEN KRÜMLER LINKS	BEARING PLATE, F-IRON CAGE ROLLER, LEFT	SEMELLE DE PALIER DU ROULEAU DE FER EN F GAUCHE
3	1	76288	LEJEPLADE TIL F-JERNS KRYMLER HØJRE	LAGERPLATTE FÜR F-EISEN KRÜMLER RECHTS	BEARING PLATE, F-IRON CAGE ROLLER, RIGHT	SEMELLE DE PALIER DU ROULEAU DE FER EN F DROITE
4	2	21398	FLANGELEJE FYTB Ø30 TF	FLANSCHEN LAGER	FLANGE BEARING	PALIER A AILE
5	4	92297	BOLT 12x50 8.8 GALV.	SCHRAUBE	SCREW	BOULON
6	4	90669	SKIVE Ø13-Ø24-2.5	UNTERLEGSCHIEBE	WASHER	RONDELLE DE SERRAGE
7	4	92050	MØTRIK M12 SELVLÅS. GLV. 8	MUTTER SELBSTSCHLIESSEND	SELFLOCKING NUT	ÉCROU DE SÉCURITÉ
8	4	92051	MØTRIK M16 SELVLÅS. GLV. 8	MUTTER	SELF-LOCKING NUT	ÉCROU
9	4	92316	BOLT 16x40 8.8 GALV. (SÆTBOLT)	SCHRAUBE	SET SCREW	BOULON

F-JERNS KRYMLER FOR 380

T-RING

76064

F-EISEN DRÜMLER
F-IRON CAGE ROLLER
ROULEAU DE NIVELLEMENT DE FER EN F

Pos.	Qty.	Part nr.	Benævnelse	Bezeichnung	Description	Designation
1	1	76368	F-JERNS KRYMLER 380 CM	F-EISEN KRÜMLER	F-IRON CAGE ROLLER	ROULEAU DE NIVELLEMENT DE FER EN F

F-jerns krymler til rørpakker, flat iron cage roller, f-eisen krümler, rouleau de nivellement de fer en f

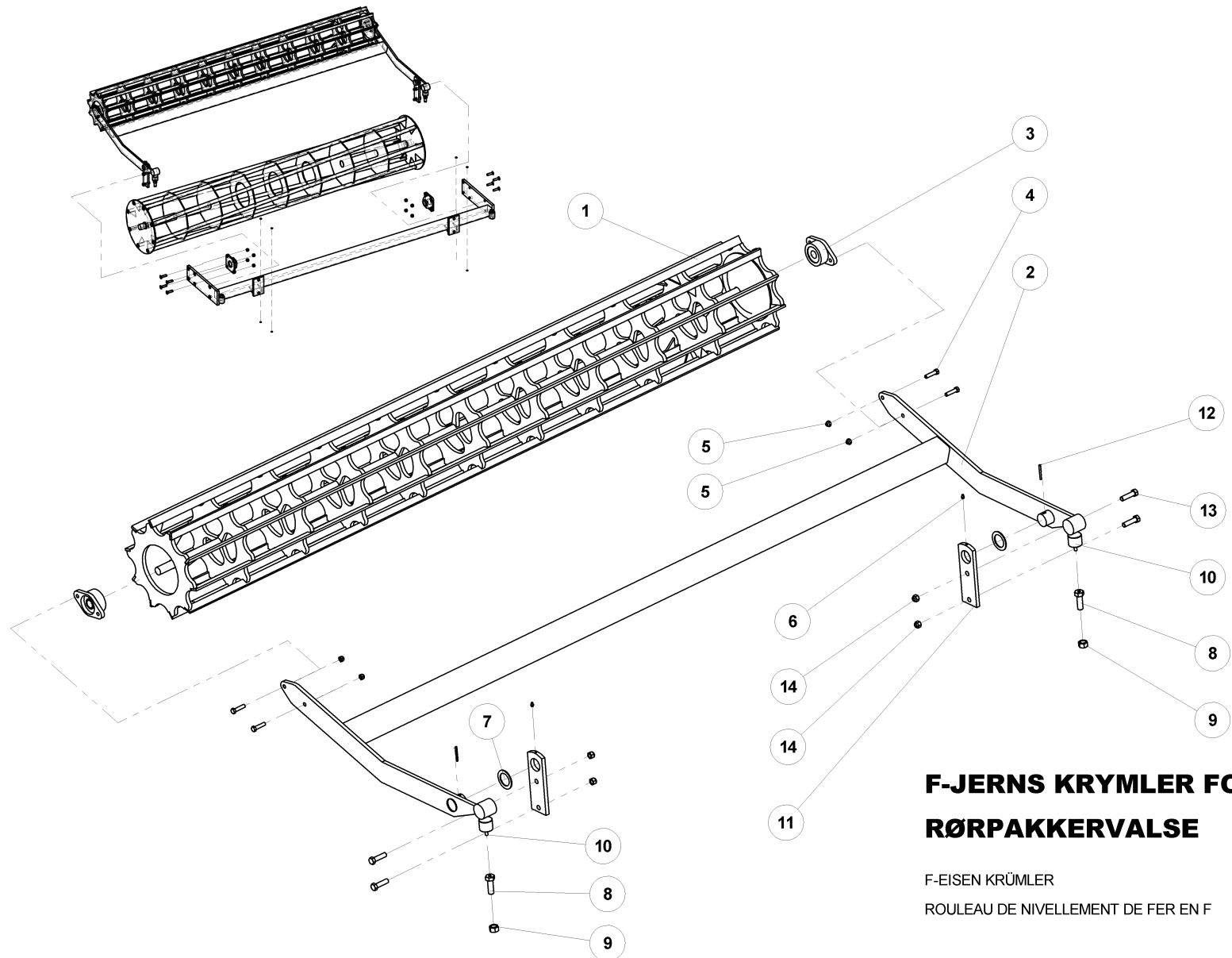

F-JERNS KRYMLER FOR 300 CM RØRPAKKERVÅLSE

F-EISEN KRÜMLER
ROULEAU DE NIVELLEMENT DE FER EN F



F-JERNS KRYMLER FOR 300 CM

RØRPAKKERVÅLSE

F-EISEN KRÜMLER

ROULEAU DE NIVELLEMENT DE FER EN F

Pos.	Qty.	Part nr.	Benævnelse	Bezeichnung	Description	Designation
1	1	76367	F-JERNS KRYMLER 300CM	ROULEAU DE NIVELLEMENT DE FER EN F	F-IRON CAGE ROLLER	F-EISEN KRÜMLER
2	1	76353	F-jerns krymlerramme, 300 cm	KRÜMLERRAHMEN	CAGE ROLLER	CADRE DE ROULEAU DE NIVELLEMENT
3	2	21398	FLANGELEJE FYTB Ø30 TF	FLANSCHEN LAGER	FLANGE BEARING	PALIER A AILE
4	4	92297	BOLT 12x50 8.8 GALV.	SCHRAUBE	SCREW	BOULON
5	4	92050	MØTRIK M12 SELVLÅS. GLV. 8	MUTTER SELBSTSCHLIESSEND	SELFLOCKING NUT	ÉCROU DE SÉCURITÉ
6	2	90721	SMØRENIPPEL M8x1	SCHMIERNIPPEL	GREASE NIPPLE	GRAISSEUR
7	2	51349	SKIVE Ø51-Ø75-3 Glv	SCHEIBE	WASHER	RONDELLE
8	2	76476	BOLT T/GUMMIKLODS JUSTERING	SCHRAUBE	RUBBER BLOCK ADJUSTMENT SCREW	BOULON
9	2	92032	MØTRIK M20 GALV. kl.8	MUTTER	NUT	ÉCROU
10	2	85375	GUMMIKLODS	GUMMIKLOTZ	RUBBER BLOCK	BLOC EN CAOUTCHOUC
11	2	76475	BOLTEFÆST. T/F-JERNS KRYMLER	BEFESTIGUNG	BOLTED PLATE FOR F-IRON CAGE ROLLER	FIXATION DE BOULON POUR ROULEAU DE FER EN F
12	2	90688	RØRSTIFT Ø 6X60 MM	ROHRSTIFT	SPLIT PIN	AXE TUBULAIRE
13	4	92318	BOLT 16x60 8.8 GALV.	SCHRAUBE	SCREW	BOULON
14	4	92051	MØTRIK M16 SELVLÅS. GLV.8	MUTTER	SELF-LOCKING NUT	ÉCROU

F-JERNS KRYMLER FOR 380 CM

RØRPAKKERVÅLSE

76003

F-EISEN DRÜMLER

F-IRON CAGE ROLLER

ROULEAU DE NIVELLEMENT DE FER EN F

Pos.	Qty.	Part nr.	Benævnelse	Bezeichnung	Description	Designation
1	1	76366	F-JERNS KRYMLER 380 CM	F-EISEN KRÜMLER	F-IRON CAGE ROLLER	ROULEAU DE NIVELLEMENT DE FER EN F
2	2	76354	F-JERNS KRYMLERRAMME, 380 CM	KRÜMLERRAHMEN	CAGE ROLLER	CADRE DE ROULEAU DE NIVELLEMENT

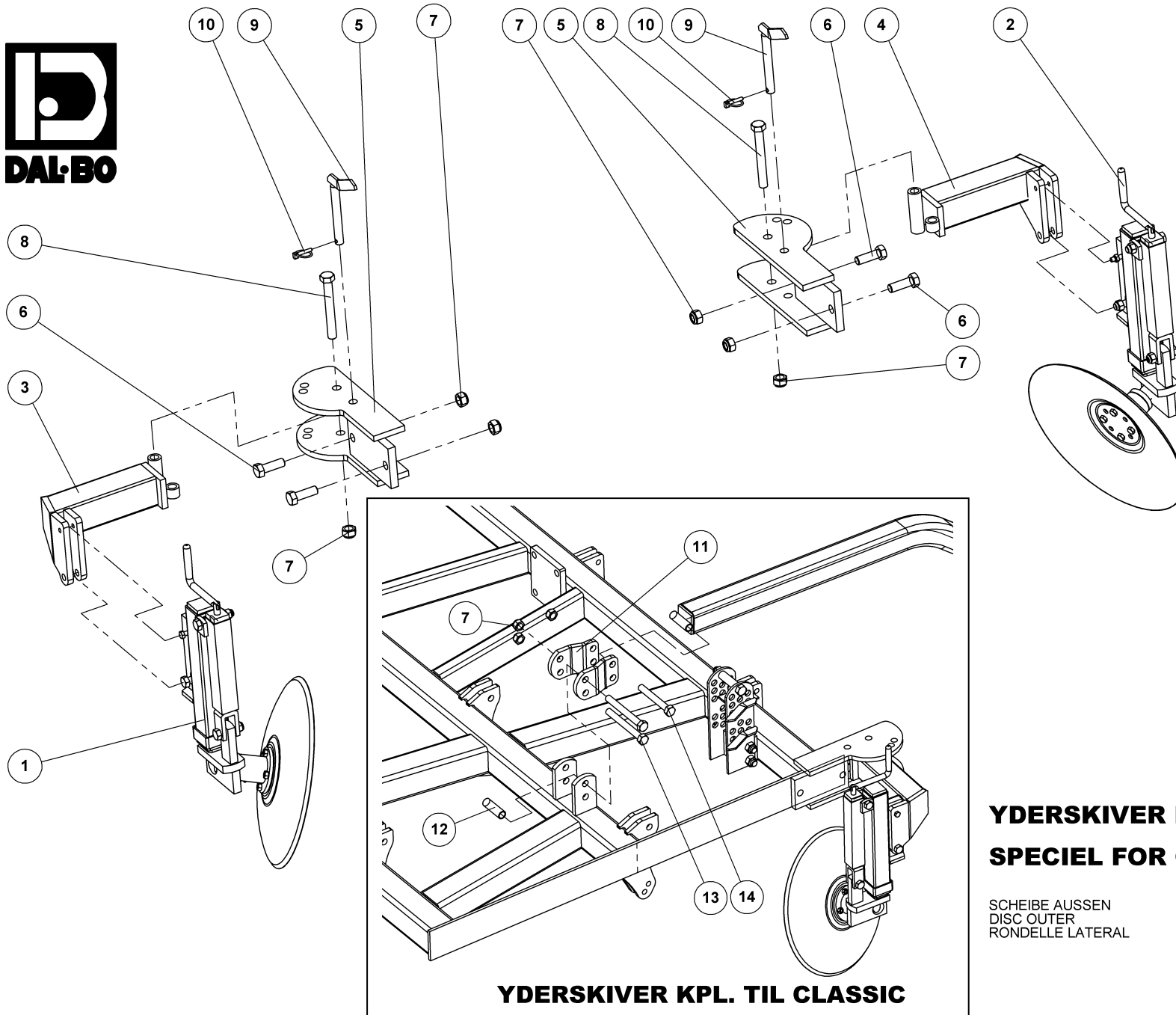

**YDESKIVER KPL. TIL CLASSIC
SPECIEL FOR GERMANY**

SCHEIBE AUSSEN
DISC OUTER
RONDELLE LATERAL

76093



YDESKIVER KPL. TIL CLASSIC

SPECIEL FOR GERMANY

76093

SCHEIBE AUSSEN
DISC OUTER
RONDELLE LATERAL

Pos.	Qty.	Part nr.	Benævnelse	Bezeichnung	Description	Designation
1	1	76088	STILK KPL. HØJRE VINGE (TYSK)	SCHEIBE ÄUSSERST, RECHTS	OUTER DISC, RIGHT	RONDELLE LATERAL, DROITE
2	1	76089	STILK KPL. VENSTRE VINGE (TYSK)	SCHEIBE ÄUSSERST, LINKS	OUTER DISC, LEFT	RONDELLE LATERAL, GAUCHE
3	1	76472	ARME, YDESKIVER H. MODEL 1999/2000	ARM, RECHTS	ARM, RIGHT	BRAS, DROITE
4	1	76473	ARME, YDESKIVER V MODEL 1999/20	ARM, LINKS	ARM, LEFT	BRAS, GAUCHE
5	2	76474	SPÆNDEBESLAG, YDESKIVER	BESCHLAG	MOUNTING PLATE	FIXATION
6	4	92334	BOLT 20x60 8.8 GALV.	SCHRAUBE	SCREW	BOULON
7	12	92052	MØTRIK M 20 SELVLÅS. GALV. 8	MUTTER SELBSTGESICHERT	SELF-LOCKING NUT	ÉCROU DE SÉCURITÉ
8	2	92603	BOLT 20x160 8.8 GALV.	SCHRAUBE	SCREW	BOULON
9	2	75503	NAGLE H Ø20X145(160)	BOLZEN	PIN	AXE
10	2	90680	RINGSPLIT Ø 8X40 FLAD	RINGSPLINT	LINCH PIN	GOUPILLE
11	2	76485	KONVERTER TIL CLASSIC	HALTER	BRACKET	SUPPORT
12	2	75609	BØSNING TIL EFTERLØBERARM	BUCHSE	BUSHING	DOUILLE
13	4	92339	BOLT 20x180 8.8 GALV.	SCHRAUBE	SCREW	BOULON
14	2	92338	BOLT 20x150 8.8 GALV.	SCHRAUBE	SCREW	BOULON

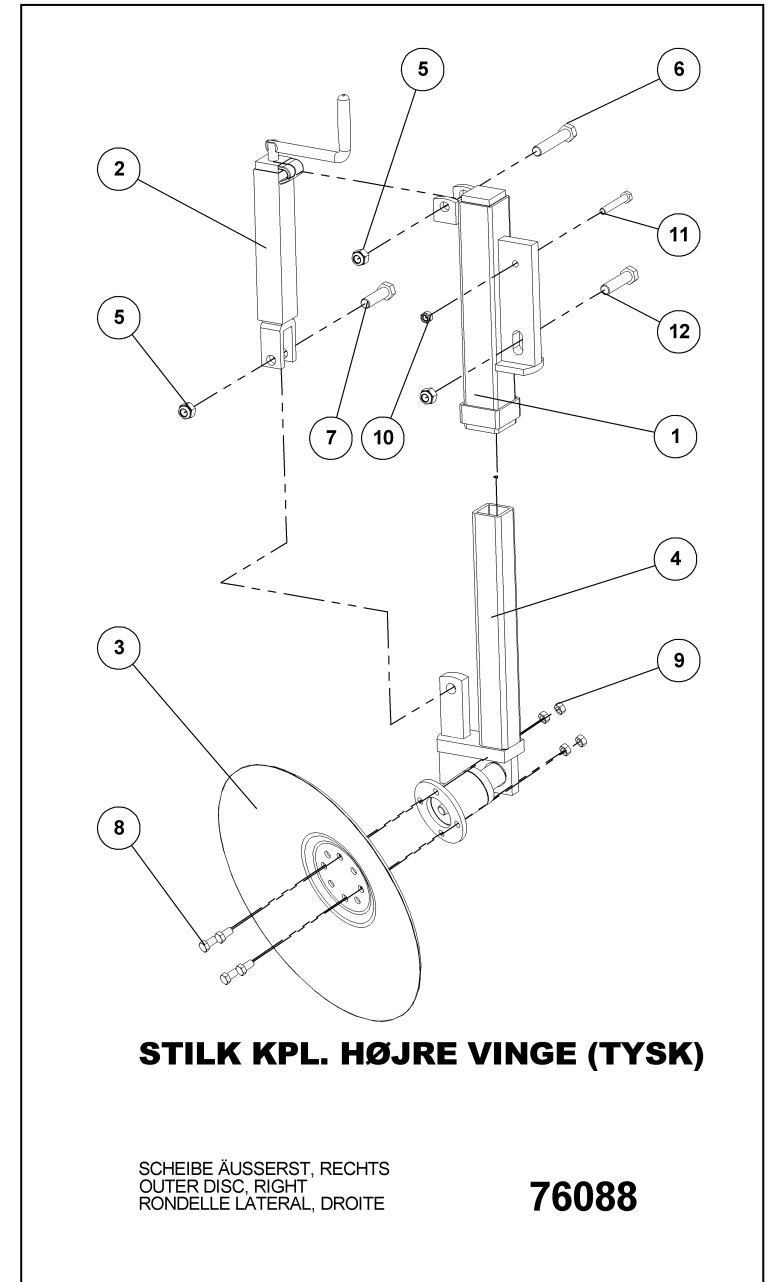
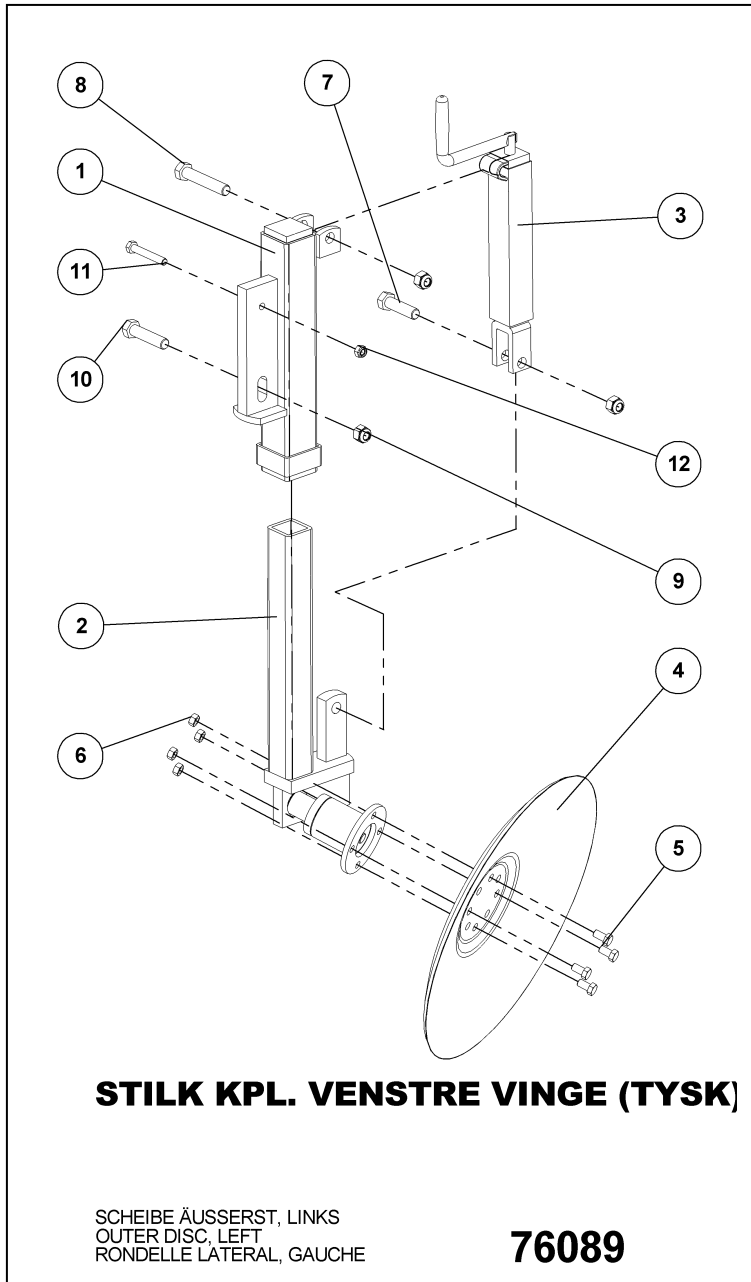



STILK KPL. VENSTRE VINGE (TYSK)

76089

SCHEIBE ÄUSSERST, LINKS
OUTER DISC, LEFT
RONDELLE LATERAL, GAUCHE

Pos.	Qty.	Part nr.	Benævnelse	Bezeichnung	Description	Designation
1	1	90460	STILK HOLDER T/SIDETALLERKEN	STIEL HALTER FÜR SEITENSCHLEIBEN	SHANK MOUNT FOR SIDE DISC	SUPPORT DE TIGE POUR DISQUE LATÉRAL
2	1	76499	STILK ENKELT VENSTRE Ø35, VINGE	STIEL EINFACH LINKS	SINGLE SHANK, LEFT	TIGE SIMPLE GAUCHE
3	1	21465	SPINDEL SHF 6-01	SPINDEL	SPINDLE	FUSEAU
4	1	75261	TALLERKEN Ø460x4 GLAT	SCHEIBE	DISC	RONDELLE
5	4	92273	BOLT 10x20 8.8 GALV. (SÆTBOLT)	SCHRAUBE	SET SCREW	BOULON
6	4	92029	MØTRIK M10 GALV. kl.8	MUTTER	NUT	ÉCROU
7	1	92318	BOLT 16x60 8.8 GALV.	SCHRAUBE	SCREW	BOULON
8	1	92321	BOLT 16x90 8.8 GALV.	SCHRAUBE	SCREW	BOULON
9	3	92051	MØTRIK M16 SELVLÅS. GLV.8	MUTTER	SELF-LOCKING NUT	ÉCROU
10	1	92319	BOLT 16x70 8.8 GALV.	SCHRAUBE	SCREW	BOULON
11	1	92278	BOLT 10X 70 8.8 GLV.	SCHRAUBE	SCREW	BOULON
12	1	92049	MØTRIK M10 SELVLÅS. GLV.8	MUTTER	SELF-LOCKING NUT	ÉCROU



STILK KPL. HØJRE VINGE (TYSK)

76088

SCHEIBE ÄUSSERST, RECHTS
OUTER DISC, RIGHT
RONDELLE LATERAL, DROITE

Pos.	Qty.	Part nr.	Benævnelse	Bezeichnung	Description	Designation
1	1	90460	STILK HOLDER T/SIDETALLERKEN	STIEL HALTER FÜR SEITENSCHLEIBEN	SHANK MOUNT FOR SIDE DISC	SUPPORT DE TIGE POUR DISQUE LATÉRAL
2	1	21465	SPINDEL SHF 6-01	SPINDEL	SPINDLE	FUSEAU
3	1	75261	TALLERKEN Ø460x4 GLAT	SCHEIBE	DISC	RONDELLE
4	1	76496	STILK ENKELT HØJRE Ø35, VINGE	STIEL EINFACH RECHTS	SINGLE SHANK, RIGHT	TIGE SIMPLE DROITE
5	3	92051	MØTRIK M16 SELVLÅS. GLV.8	MUTTER	SELF-LOCKING NUT	ÉCROU
6	1	92321	BOLT 16x90 8.8 GALV.	SCHRAUBE	SCREW	BOULON
7	1	92318	BOLT 16x60 8.8 GALV.	SCHRAUBE	SCREW	BOULON
8	4	92273	BOLT 10x20 8.8 GALV. (SÆTBOLT)	SCHRAUBE	SET SCREW	BOULON
9	4	92029	MØTRIK M10 GALV. kl.8	MUTTER	NUT	ÉCROU
10	1	92049	MØTRIK M10 SELVLÅS. GLV.8	MUTTER	SELF-LOCKING NUT	ÉCROU
11	1	92278	BOLT 10X 70 8.8 GLV.	SCHRAUBE	SCREW	BOULON
12	1	92319	BOLT 16x70 8.8 GALV.	SCHRAUBE	SCREW	BOULON

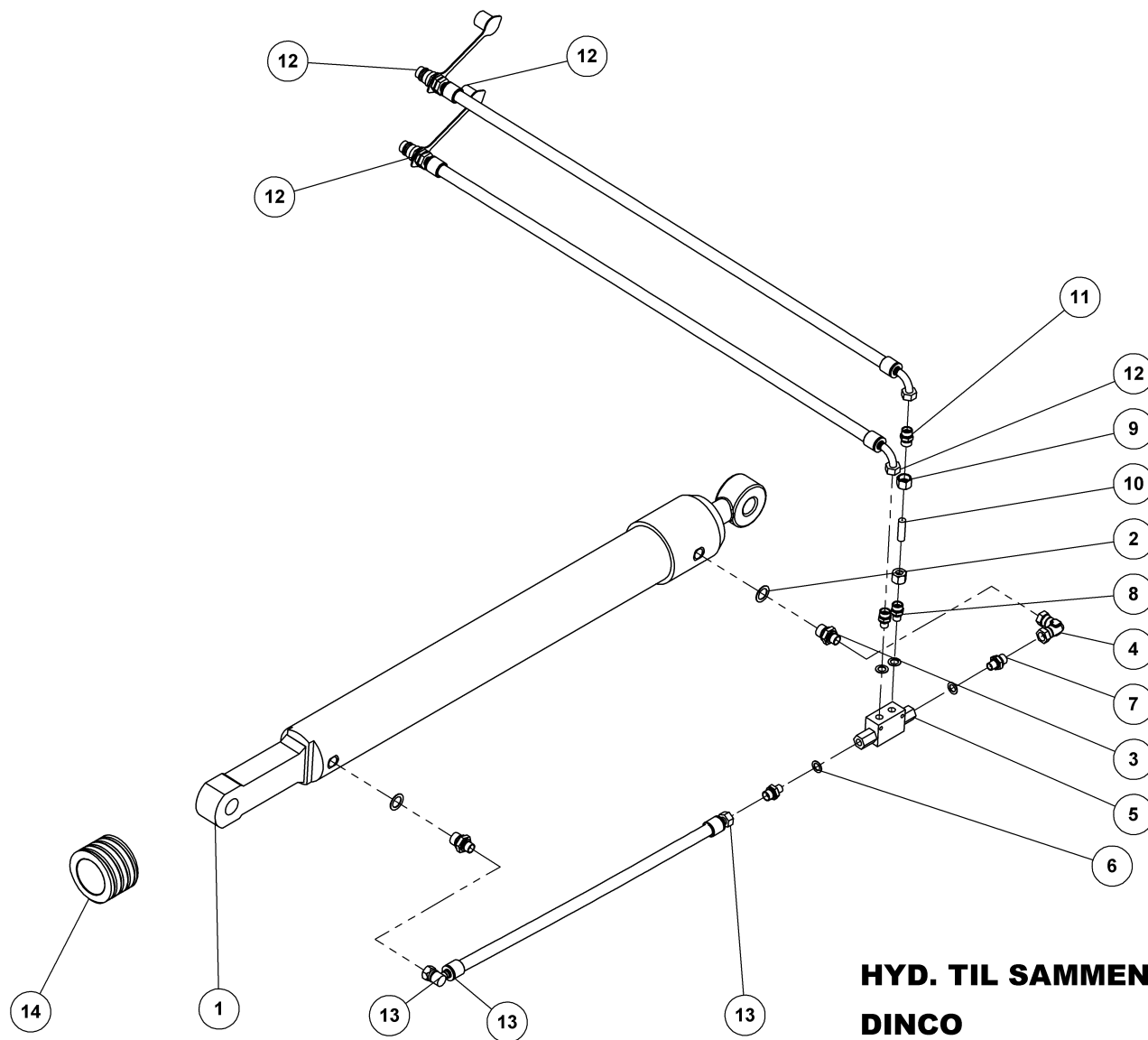

**HYD. TIL SAMMENKLAP 380+470
DINCO**

76180



HYD. TIL SAMMENKLAP 380+470

DINCO

76180

Pos.	Qty.	Part nr.	Benævnelse	Bezeichnung	Description	Designation
1	1	76525	CYLINDER 90/40/800 INDB MÅL 1242MM	ZYLINDER	CYLINDER	CYLINDRE
2	2	91029	1/2" BONDED SEALS PAKRING	BONDED SEALS PACKRING	BONDED SEAL WASHER	JOINT BONDED SEALS
3	2	91074	BRYSTNIPPEL 1/2"RG /3/8"RG GALV	VERSCHRAUBUNG	HEXAGON NIPPLE CONNECTOR	RACCORD DE JONCTIONS MÂLES
4	1	91067	VINKEL 3/8" 90 FEMALE/FEMALE	WINKEL	CONNECTOR	ANGLE
5	1	27396	PILOTSTYRET KONTRAVENTIL 1/4" - ENKELT	PILOTGESTEUERTES SPERRVENTIL EINFACH	PILOT-OPERATED CHECK VALVE, SINGLE	CLAPET DE BLOCAGE PILOTE SIMPLE
6	4	91027	1/4" BONDED SEALS PAKRING	BONDED SEALS PACKRING	BONDED SEAL WASHER	JOINT BONDED SEALS
7	2	91000	BRYSTNIPPEL 1/4"RG / 3/8"RG GALV	VERSCHRAUBUNG	HEXAGON NIPPLE CONNECTOR	RACCORD DE JONCTIONS MÂLES
8	2	91045	LIGE FORSKRUNING M18 x 1/4"	GERADE VERSCHRAUBUNG	STRAIGHT CONNECTION	JOINT DROIT
9	2	91103	OMLØBER M/SKÆRERING M18	VERSCHRAUBUNG	ADAPTOR	RACCORD
10	1	13315	DRØVLING Ø1.0	DROSSEL	THROTTLE	GRIVE
11	1	91078	Lige forskrning M18 x M18	GERADE VERSCHRAUBUNG	STRAIGHT CONNECTION	JOINT DROIT
12	2	76502	HYDR. SLANGE HAN/VINKEL M18	SCHLAUCH	HOSE	TUYAU
13	1	76503	HYDR. SLANGE VINKEL 3/8"/LIGE 3/8"	HYDR. SCHLAUCH WINKEL GERADE	HYDR. HOSE, ANGLE / STRAIGHT	TUYAU HYDR. ANGLE/DROIT
14	1	76182	BØSNING TIL DINCO INDKLAP			