



**Reservedele
Spareparts
Ersatzteile
Pieces**

**Minimax
950/1030
Serie: 51594-54161**

Indholdsfortegnelse,

Table of Contents, Inhaltsverzeichnis, Table des matières

RESERVEDELSLISTENS OPBYGNING, THE CONSTRUCTION OF THE SPAREPARTSLIST	3
MINIMAX 1030	4
TRÆK FLANGE, ZUG, DRAWBAR, ATTELAGE	7
NAV KPL. MONROC Ø60/A445, NABE, HUB, MOYEU.....	8
GODS PÅ AKSEL SIDE CAMBRIDGE 50, METAL ON SHAFT, GIESSGUT AUF WELLEN, METAL SUR ARBRES	10
950+1030	11
GODS PÅ AKSEL CROSSKILL 48/53, METAL ON SHAFT, GIESSGUT AUF WELLEN, METAL SUR ARBRES	12
950+1030	13
HYDRAULIK.....	14
<i>Vippecyliner 950/1030, tilting cylinder, kippzylinder, verrin de basculement</i>	<i>14</i>
<i>Sammenklap 950/1030, folding cylinder, aus/zusammenklappen Zylinder, verrin de repliage.....</i>	<i>16</i>
EKSTRAUDSTYR, OPTIONS, ZUSATZAUSRÜSTUNG, ACCESSOIRES EN OPTION	18
CRACKERBOARD 950, CRACKERBOARD,	18
HYDRAULIK.....	20
<i>Crackerboard 950/1030.....</i>	<i>20</i>
LYS, LIGHT SET, BELEUCHTUNGSANLAGE, ENSEMBLE DE PHARES	22
TRYKLUFTSBREMSE, BREMSE, BRAKES, FREIN	24

Reservedelslistens opbygning, the construction of the sparepartslist

<p>Reservedelstegningerne tager udgangspunkt i en Minimax 1030. Ved de øvrige modeller er der udarbejdet en ekstra reservedelsliste hvor i forskellene som hoveddrammer mm. fremgår</p>	<p>The spare parts drawings have there point of origin in a Minimax 1030. For the other models there is made an extra spare parts list, where the differences is shown.</p>	<p>Die Ersatzteilzeichnungen sind ursprünglich von der Minimax 1030. Für die anderen Typen gibt es eine separate Ersatzteilliste, die Unterschiede aufzeigt.</p>	<p>Les dessins des pièces détachées sont basés sur un Minimax. Pour les autres modèles une liste supplémentaire de pièces est établie où les différences sont montrées.</p>
<p>For deres sikkerhed samt for funktionsdygtigheden af deres maskine, bør der kun anvendes originale Dal-bo reservedele til deres maskine</p> <p>Når de bestiller reservedele bør de altid informere om:</p> <ul style="list-style-type: none"> • Reservedelsnummer • Maskinens typenummer • Antal styk af reservedelen 	<p>For your safety and for the functions of the mashing, you should only use original spare parts for m Dalbo.</p> <p>When you order spare parts, you should always inform about:</p> <ul style="list-style-type: none"> • Spare part number • The mashing type number • Amount of spare parts pieces 	<p>Zu Ihrer Sicherheit und zur einwandfreien Funktion ihres Gerätes sollten sie unbedingt nur original DAL-BO Ersatzteile verwenden.</p> <p>Wenn sie Ersatzteile bestellen bitte folgendes beachten:</p> <ul style="list-style-type: none"> • Ersatzteil-Nummer • Geräte-Nummer und -typ • Anzahl der Ersatzteile 	<p>Pour votre sécurité et pour les fonctions du matériel, vous devez utiliser uniquement des pièces détachées d'origine DALBO.</p> <p>Lorsque vous commandez vos pièces détachées, vous devez toujours nous indiquer :</p> <ul style="list-style-type: none"> • Le numéro de la pièce • Le type de la machine • La quantité des pièces détachées.

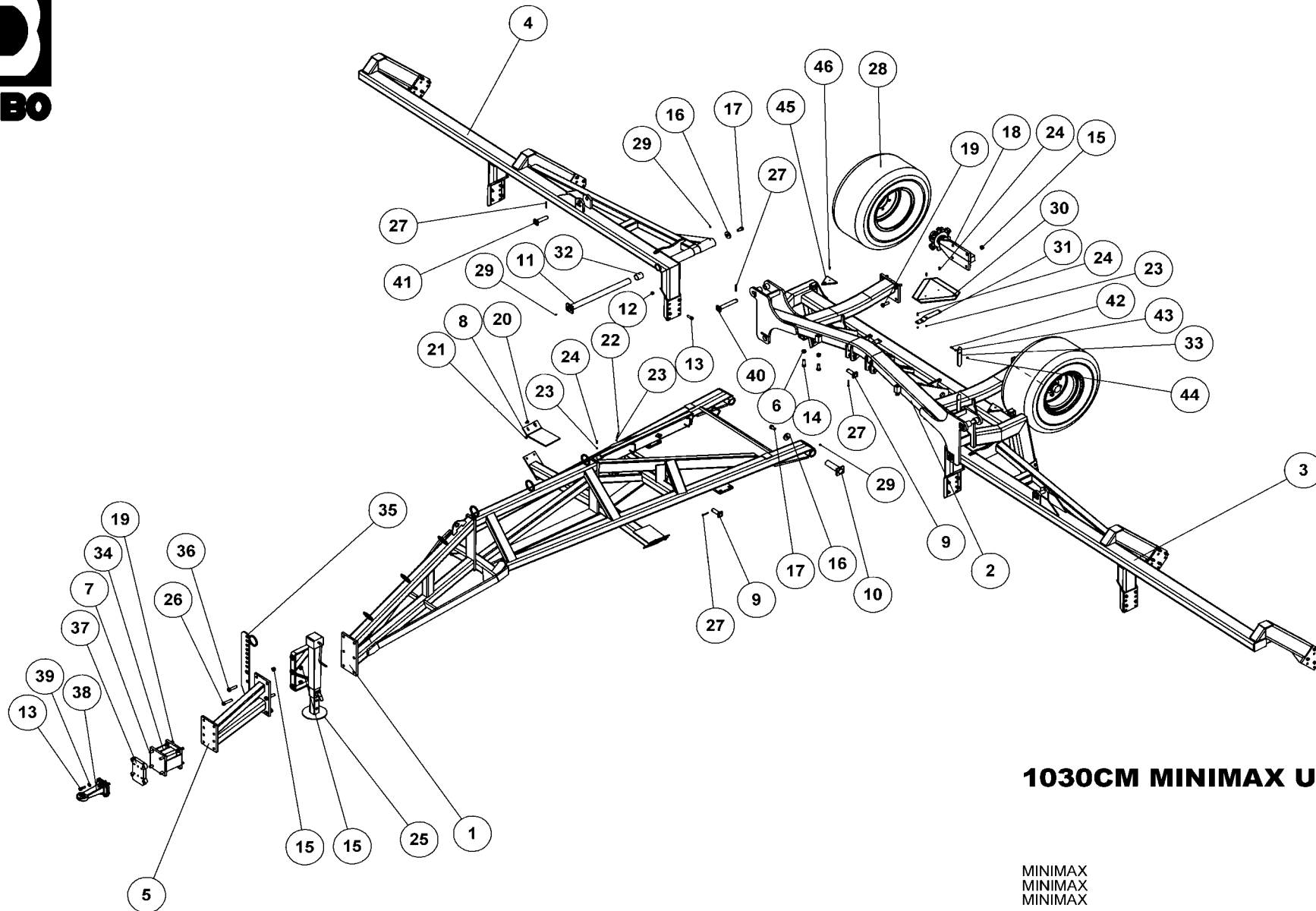

1030CM MINIMAX U. G/A/H

MINIMAX
MINIMAX
MINIMAX

23496



1030CM MINIMAX U. G/A/H

23496

MINIMAX
MINIMAX
MINIMAX

Pos.	Qty.	Part nr.	Benævnelse	Bezeichnung	Description	Designation
1	1	37255	TRÆK 9,50	ZUG	DRAWBAR	ATTELAGE
2	1	23493	MIDTERSEKTION MINIMAX 1030	MITTLERE SEKTION	MIDDLE SECTION	SECTION CENTRALE
3	1	23495	SIDSEKTION VENSTRE 1030	SEITENSEKTION LINKS	SIDE SEKTION LEFT	SECTION LATÉRALE GAUCHE.
4	1	23494	SIDSEKTION HØJRE 1030	SEITENSEKTION RECHTS	SIDE SEKTION RIGHT	SECTION LATÉRALE DROITE
5	1	37252	TRÆK, MELLESTYKKE	ZUG	DRAWBAR	ATTELAGE
6	4	92032	MØTRIK M20 GALV. kl.8	MUTTER	NUT	ÉCROU
7	6	92335	BOLT 20x50 8.8 GALV. (SÆTBOLT)	SCHRAUBE	SET SCREW	BOULON
8	2	37632	GODS HVILER	SPITZE GEBOGEN	CB POINT	POINT
9	4	71384	NAGLE F Ø30X80(108)	BOLZEN	PIN	AXE
10	2	37361	NAGLE F Ø50X170(185)M20 ind.	BOLZEN	PIN	AXE
11	2	37359	NAGLE F Ø50X690(705)M20 ind.	BOLZEN	PIN	AXE
12	40	92051	MØTRIK M16 SELVLÅS. GLV.8	MUTTER	SELF-LOCKING NUT	ÉCROU
13	46	92317	BOLT 16x50 8.8 GALV. (SÆTBOLT)	SCHRAUBE	SET SCREW	BOULON
14	2	92346	BOLT 20x60 8.8 GALV. (SÆTBOLT)	SCHRAUBE	SET SCREW	BOULON
15	18	92052	MØTRIK M20 SELVLÅS. GALV. 8	MUTTER SELBSTGESICHERT	SELF-LOCKING NUT	ÉCROU DE SÉCURITÉ
16	4	74529	SKIVE Ø21-Ø69-10	UNTERLEGSCHLEIBE	WASHER	RONDELLE DE SERRAGE
17	4	92349	BOLT 20x40 8.8 GALV. (SÆTBOLT)	SCHRAUBE	SCREW	BOULON
18	2	25220	NAV MED FLANGE	NABE	HUB	MOYEU
19	14	92334	BOLT 20x60 8.8 GALV.	SCHRAUBE	SCREW	BOULON
20	4	92381	BOLT 10X30 GALV. 8.8 (BRÆDDEBOLT)	SCHRAUBE	BOARD BOLT	BOULON
21	4	92049	MØTRIK M10 SELVLÅS. GLV.8	MUTTER	SELF-LOCKING NUT	ÉCROU
22	2	92252	BOLT 6x45 8.8 GALV.	SCHRAUBE	SCREW	BOULON
23	8	92027	MØTRIK M6 GALV. kl.8	MUTTER	NUT	ÉCROU
24	6	92249	BOLT 6X25 GALV. DIN 7985	SCHRAUBE	SCREW	BOULON
25	1	37245	MAXIROLL STØTTEBEN 2500 KG	STÜTZFUSS	JACK	BÉQUILLE
26	2	92372	BOLT 20x90 8.8 GALV.	SCHRAUBE	SCREW	BOULON
27	8	90677	SPLIT 8X50 MM GALV.	SPLINT	SPLIT PIN	GOUPILLE.
28	2	25259	HJUL KPL. 400/60-15.5 14 PLY	RAD	WHEEL	ROUE
29	6	90721	SMØRENIPPEL M8x1	SCHMIERNIPPEL	GREASE NIPPLE	GRAISSEUR
30	1	34213	ADVARSELREFLEKS - STOR	WARN DREIECK	WARNING TRIANGLE	ECRITEAU AVERTISSEUR
31	1	34222	ADVARSELSTREKANT BESLAG	BESCHLAG	MOUNTING PLATE	FIXATION
32	4	91900	GLACIERLEJE PM5060DX	GLEITLAGER	PLAIN BEARING	PALIER ENDURCI
33	1	37581	PENDUL	PENDEL	PENDULUM	PENDULE
34	1	37257	TRÆKFORLÆNGER 200 MM	VERLÄNGERUNGSSTÜCK FÜR DEN AXR-H ZUG	EXTENSION PIECE FOR AXR-H LINKAGE	RALLONGE POUR ATTELAGE
35	1	37242	SLANGEHOLDER	SCHLAUCHHALTER	HOSE CLAMP	SUPPORT DE TUYAU
36	2	92336	BOLT 20 X 80 8.8 GALV.	SCHRAUBE	SCREW	BOULON
37	1	37699-1	GEVIND SVEJSEPLADE F/ROCKING	BESCHLAG	MOUNTING PLATE	FIXATION
38	1	25245	SCHARMÜLLER Ø40MM - 2000KG	ZUG	DRAWBAR	ATTELAGE
39	6	90663	SKIVE Ø17-Ø35-2	SCHLEIBE	WASHER	RONDELLE
40	2	37530	NAGLE F Ø30X190(218)	BOLZEN	PIN	AXE
41	2	37529	NAGLE F Ø30X110(138)	BOLZEN	PIN	AXE
42	1	92261	BOLT 8x30 8.8 GALV.	SCHRAUBE	SCREW	BOULON
43	1	92028	MØTRIK M8 GALV. kl.8	MUTTER	NUT	ÉCROU
44	1	92048	MØTRIK M8 SELVLÅS. GLV.8	MUTTER	SELF-LOCKING NUT	ÉCROU
45	2	90923	REFLEX RØD JUR 472 PLAST	REFLEX	REFLEX	REFLET
46	4	92401	GALOPSKRUE PZD. L/H 4.8 x 16	TAPTITE	TAPTITE	TAPTITE

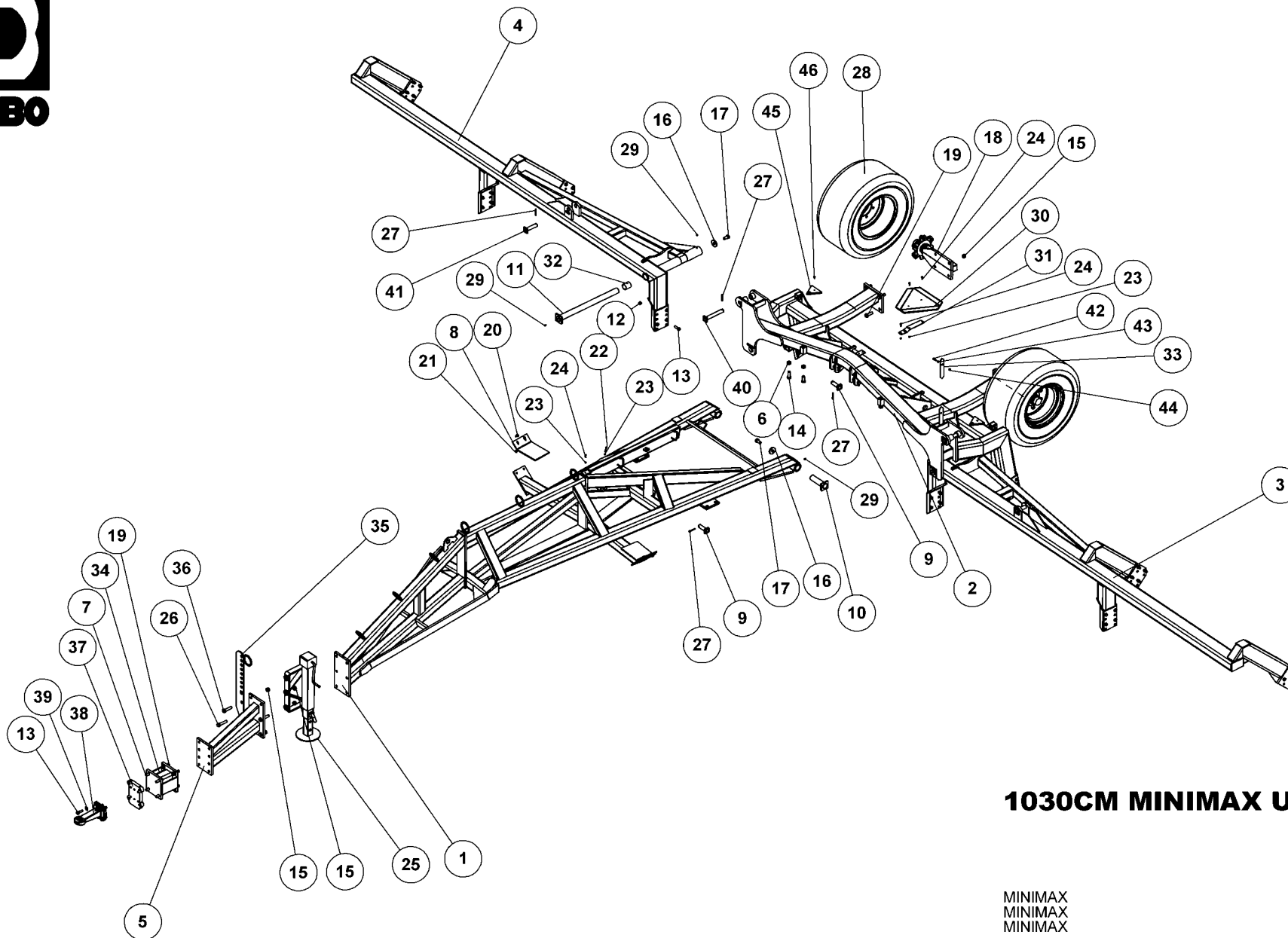

1030CM MINIMAX U. G/A/H

MINIMAX
MINIMAX
MINIMAX

23496

950CM MINIMAX U. G/A/H

23499

MINIMAX
MINIMAX
MINIMAX

Pos.	Qty.	Part nr.	Benævnelse	Bezeichnung	Description	Designation
3	1	23498	SIDSEKTION VENSTRE 950	SEITENSEKTION LINKS	SIDE SECTION LEFT	SECTION LATÉRALE GAUCHE
4	1	23497	SIDSEKTION HØJRE 950	SEITENSEKTION RECHTS	SIDE SECTION RIGHT	SECTION LATÉRALE DROITE
34	-	-	-	-	-	-

Træk flange, Zug, drawbar, attelage

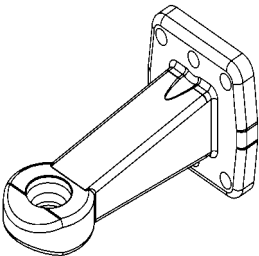
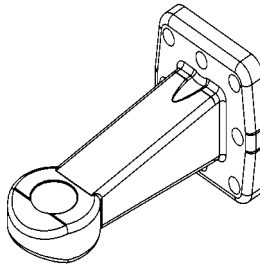
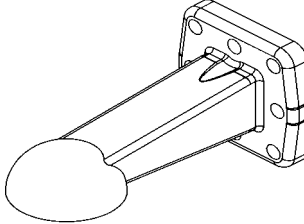
 <p>SCHARMÜLLER Ø40MM FLANGE 100X110XM16</p> <p>ZUG DRAWBAR ATTELAGE</p> <p>25245</p>	 <p>SCHARMÜLLER Ø50MM FLANGE 100X110XM16</p> <p>ZUG DRAWBAR ATTELAGE</p> <p>25247</p>	 <p>SCHARMÜLLER K80 FLANGE 100X110XM16</p> <p>ZUG DRAWBAR EYE CROCHET D'ATTELAGE</p>
---	---	---

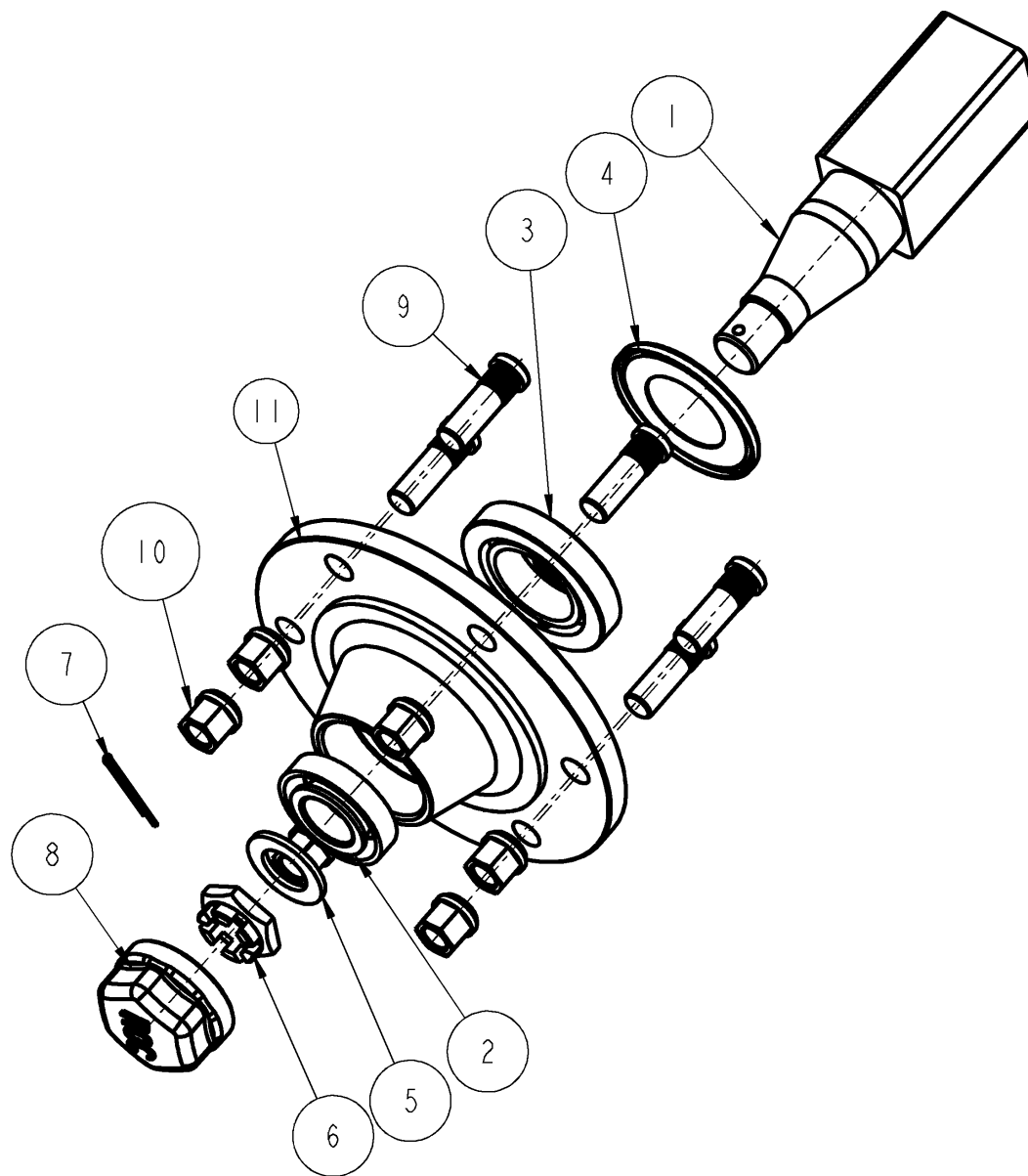

33207

NAV KPL. MONROC Ø60/A450, NABE, HUB, MOYEU

33207

Pos.	Qty.	Part nr.	Benævnelse	Bezeichnung	Description	Designation
1	1	33210	AKSEL	WELLE	SHAFT	ARBRE
2	1	12849	LEJE 30207	LAGER	BEARING	FIXATION
3	1	12863	LEJE 30211	LAGER	BEARING	FIXATION
4	1	33211	TÆTNINGSRING	DICHTUNGSRING	SEAL	BAGUE D'ÉTANCHEITE
5	1	33212	SKIVE 31X52X4	SCHEIBE	WASHER	RONDELLE DE SERRAGE
6	1	33213	KRONEMØTRIK	ACHSENMUTTER	SHAFT NUT	ECROU D'ARBRE
7	1	33214	SPLIT	SPLINTE	SPLIT PIN	GOUPILLE
8	1	33215	NAVKAPSEL	NABEKAPSEL	HUB CAP	BOITE DE MOYEU
9	6	23452	NAVBOLT M18X1,5 – 40/54	SCHRAUBE	SCREW	BOULON
10	6	23453	NAVMØTRIK M18	MUTTER	NUT	ECROU

Gods på aksel side Cambridge 50, Metal on shaft, Giessgut auf Wellen, Metal sur arbres

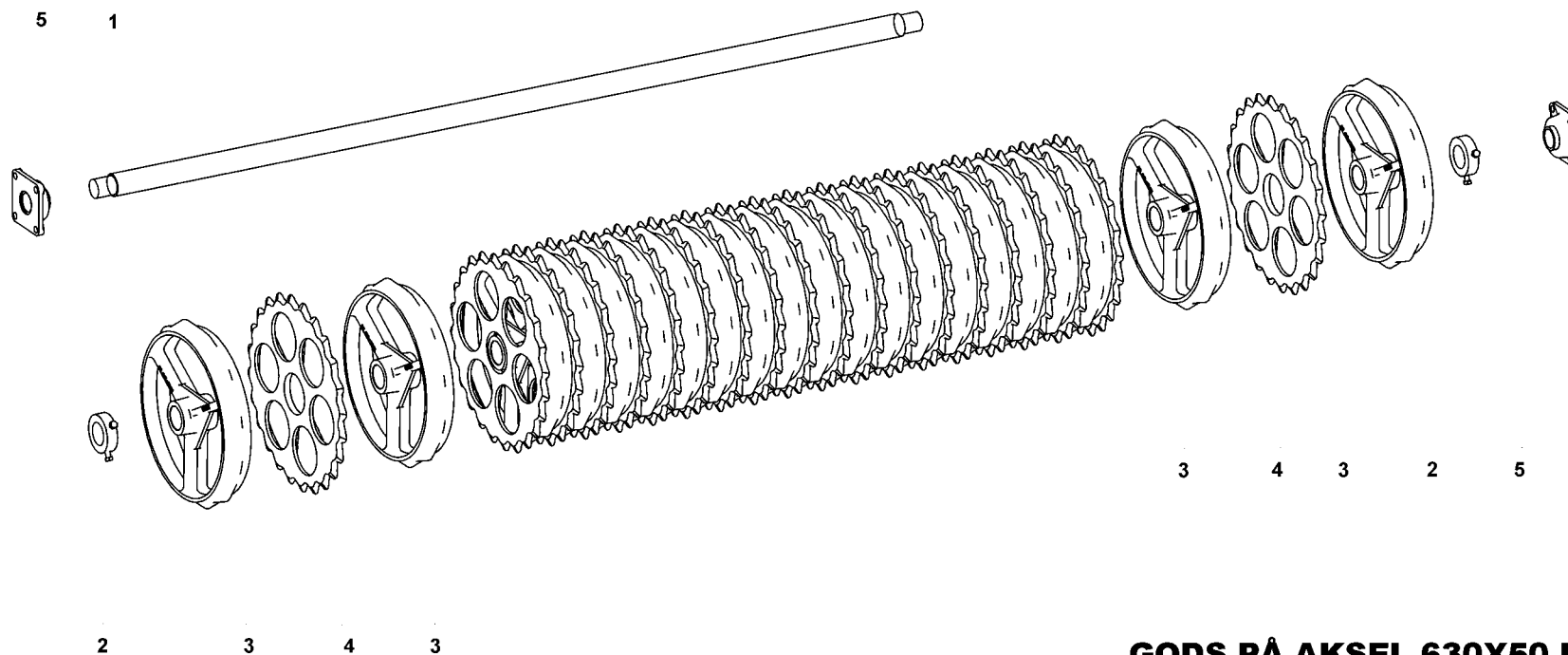

GODS PÅ AKSEL 630X50 L=2440

SATZ GIESSGUT FÜR DIE WELLEN
METAL SET FOR AXLE
MÉTAL SUR ARBRES

37216





GODS PÅ AKSEL 630X50 L=2440

37216

SATZ GIESSGUT FÜR DIE WELLEN
METAL SET FOR AXLE
MÉTAL SUR ARBRES

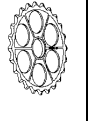
Pos.	Qty.	Part nr.	Benævnelse	Bezeichnung	Description	Designation
1	1	23384	AKSEL Ø60X2440	ACHSE	SHAFT	ARBRE
2	2	12334	STOPRING Ø 60 KPL.	ANSCHLAGRING	STOP BUSHING	BAGUE D'ARRÊT
3	21	15384	50CM GLAT RING Ø60	GLATTER RING	SMOOTH RING	ANNEAU LISSE
4	20	15385	50CM TAKKET RING Ø60	GEZAHNTER RING	NOTCHED RING	ANNEAU DENTÉ
5	2	12391	KOMPLET Y-LEJE FY 50 TL	KOMPLETTES Y-LAGER	COMPLETE Y-BEARING	PALIER-Y COMPLET

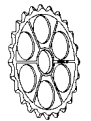
							Komplet gods Metal set for axle Satz giessgut für Wellen Métal sur arbres	Lejer Bearing Lager Palier	Stopringe Stop bushing Anschlagring Bague d'arrêt	Aksel midt Shaft, middle section Achse, mittlere sektion Arbre, section central	Aksel side Shaft, side sektion Achse, seitensektion Arbre, section lateral	
	Cambridge											
	50 cm		55 cm				50	55				
Model	15384	15385	15484	15485					12391	12334		
Minimax 950	101	96	101	96			37140	37141	10	10	23386	23385 / 23380
Minimax 1030	109	104	109	104			37145	37146	10	10	23386	23385 / 23363



GODS PÅ AKSEL 630X53 L=2440

37215

SATZ GIESSGUT FÜR DIE WELLEN
METAL SET FOR AXLE
MÉTAL SUR ARBRES

Pos.	Qty.	Part nr.	Benævneelse	Bezeichnung	Description	Designation
1	1	23384	AKSEL Ø60X2440	ACHSE	SHAFT	ARBRE
2	10	18103	CROSSKILL BØSNING Ø90/62	CROSSKILL BUCHSE	CROSSKILL BUSHING	DOUILLE CROSSKILL
3	10	18102	CROSSKILL RING Ø530/160	ZYLINDER	CROSSKILL RING	ANNEAU CROSSKILL
4	11	18101	CROSSKILL RING Ø480/62	CROSSKILL RING	CROSSKILL RING	ANNEAU CROSSKILL
5	2	12334	STOPRING Ø 60 KPL.	ANSCHLAGRING	STOP BUSHING	BAGUE D'ARRÊT
6	2	12391	KOMPLET Y-LEJE FY 50 TL	KOMPLETTES Y-LAGER	COMPLETE Y-BEARING	PALIER-Y COMPLET

							Komplet gods Metal set for axle Satz giessgut für Wellen Métal sur arbres		Lejer Bearing Lager Palier	Stopringe Stop bushing Anschlagring Bague d'arrêt	Aksel midt Shaft, middle section Achse, mittlere sektion Arbre, section central	Aksel side Shaft, side sektion Achse, seitensektion Arbre, section lateral
	Crosskill 48/53 cm			Crosskill 55/60 cm			48/53	55/60				
Model	18101	18102	18103	18125	18126	18127			12391	12334		
Minimax 950	52	47	47	52	47	47	37143	37118	10	10	23386	23385/23380
Minimax 1030	56	51	51	56	51	51	37147	37148	10	10	23386	23385 / 23363

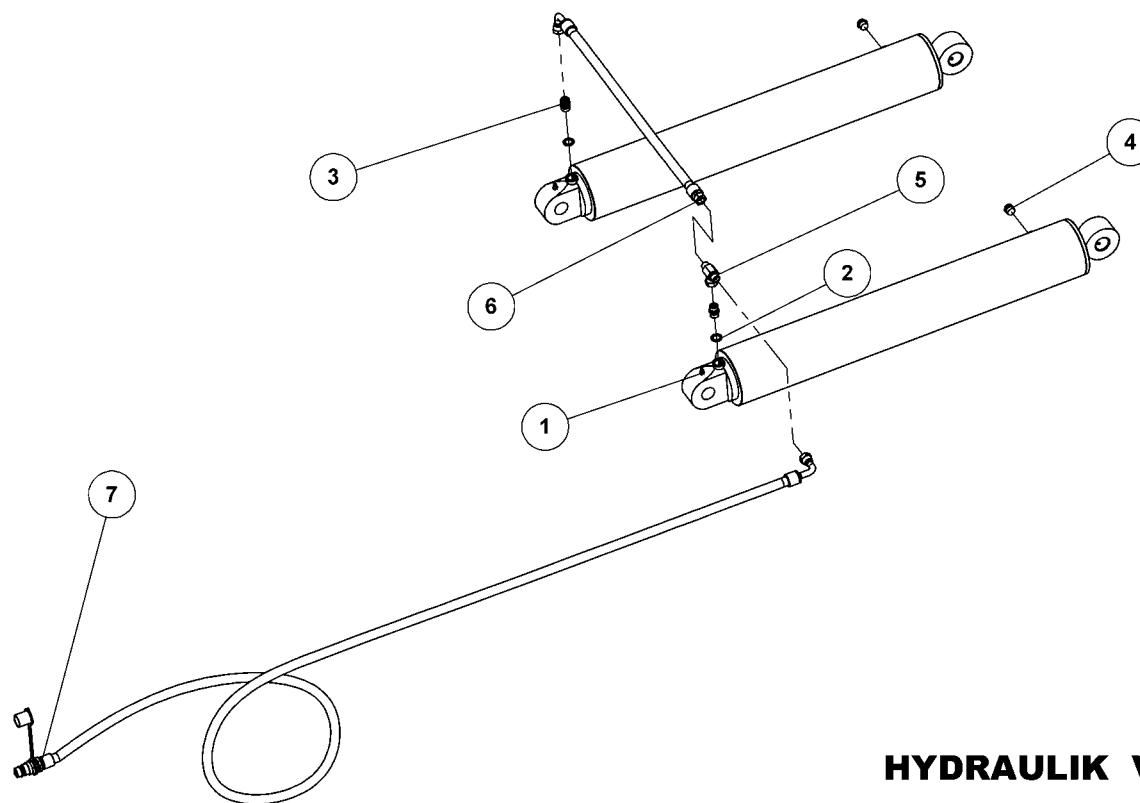

HYDRAULIK VIPPECYLINDER 950

KIPPZYLINDER
TILTING CYLINDER
VERRIN DE BASCULEMENT

37490



HYDRAULIK VIPPECYLINDER 950

37490

KIPPZYLINDER
TILTING CYLINDER
VERRIN DE BASCULEMENT

Pos.	Qty.	Part nr.	Benævnelse	Bezeichnung	Description	Designation
1	2	91860	CYLINDER 526-AD-110/50X700-A	ZYLINDER	CYLINDER	VERRIN
2	2	91028	3/8" BONDED SEALS PAKRING	BONDED SEALS PAKRING	BONDED SEAL WASHER	JOINT BONDED SEALS
3	2	91133	DRØVL-BRYSTNIPPEL 3/8" X 3/8" - Ø2,5	DROSSEL-VERSCHRAUBUNG	THROTTLE, HEXAGON NIPPLE CONNECTOR	RACCORD DE JONTIONS MÂLES-GRIVE
4	2	91088	UDLÜFTNINGSPROP 3/8" RG	LÜFTUNGSSTÖPSEL	AIR RELIEF PLUG	BOUCHON DE VENTILATION
5	1	91014	T-STYKKE 3/8"BSP MA/MA/FEMALE	T-STÜCK	T-PIECE	T-PIÈCE
6	1	37458	SLANGE VINKEL 3/8 + LIGE M18 L=180 MM	SCHLAUCH	HOSE	TUYAU
7	1	37457	SLANGE HAN + VINKEL 3/8 L=5700 MM	SCHLAUCH	HOSE	TUYAU

91860 CYLINDER 110/50X700

ZYLINDER
CYLINDER
VERRIN

Pos.	Qty.	Part nr.	Benævnelse	Bezeichnung	Description	Designation
1a	1	91861	PAKNINGSSÆT 110/50	DICHTUNG FÜR ZYLINDER	SET OF SEALINGS	JEU DE JOINTS VERRIN
1b	1	91862	STEMPELSTANG	KOLBENSTANGE	PISTON ROD	TIGE DE VERRIN

91828 CYLINDER 120/60X700

ZYLINDER
CYLINDER
VERRIN

Pos.	Qty.	Part nr.	Bezeichnung	Description	Designation
1.1a	1	91833	DICHTUNG FÜR ZYLINDER	SET OF SEALINGS	JEU DE JOINTS VERRIN
1.1b	1	91829	KOLBENSTANGE	PISTON ROD	TIGE DE VERRIN

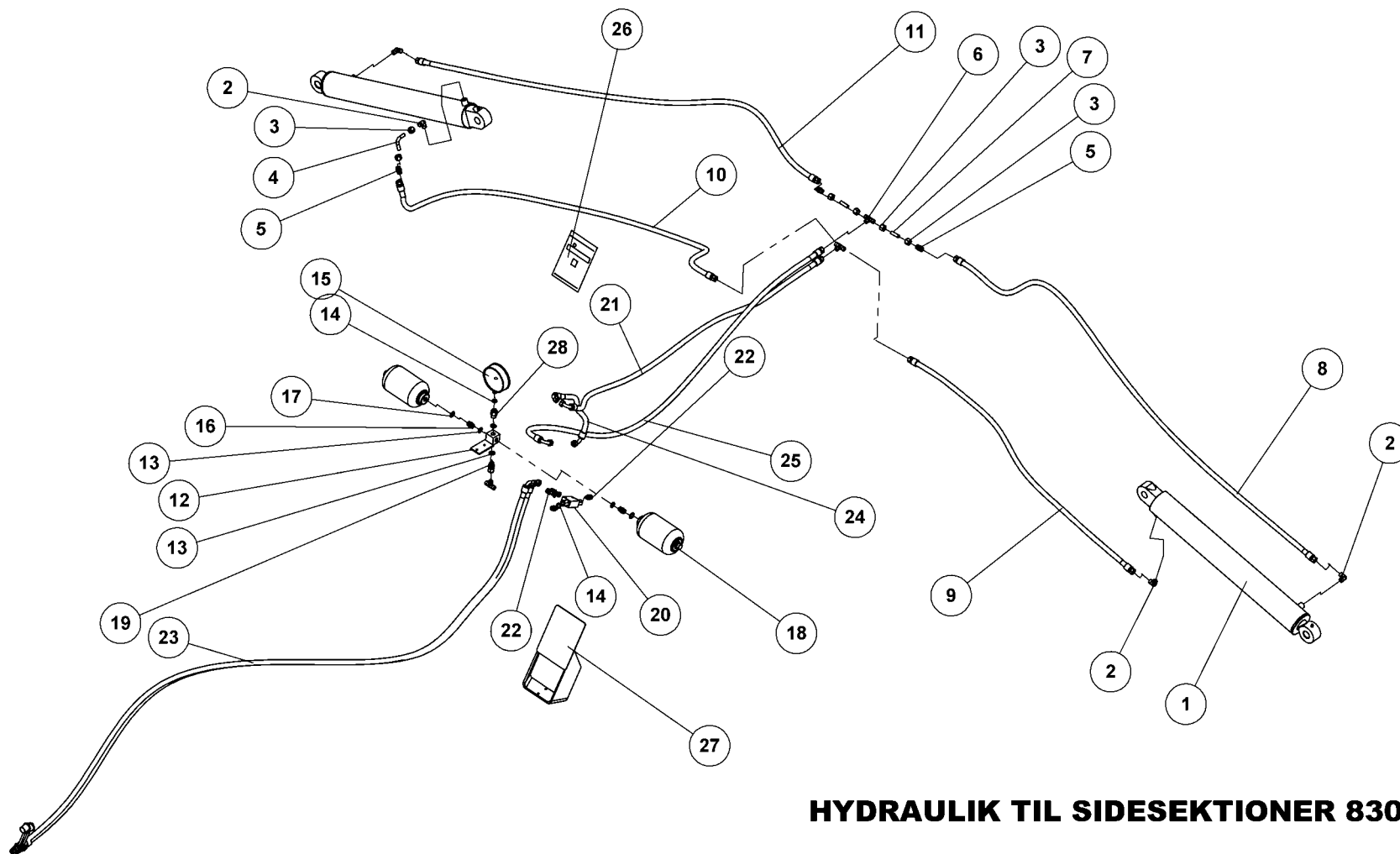

HYDRAULIK TIL SIDSEKTIONER 830

MAXIROLL GREENLINE

HYDRAULIK
HYDRAULIC
HYDRAULIQUE

37415



HYDRAULIK TIL SÍDESEKTIONER 830 MAXIROLL GREENLINE

37415

HYDRAULIK
HYDRAULIC
HYDRAULIQUE

Pos.	Qty.	Part nr.	Benævnelse	Bezeichnung	Description	Designation
1	2	91835	CYLINDER 90/50X700	ZYLINDER	CYLINDER	CYLINDRE
2	4	91005	Vinkel 3/8" x M18s	WINKEL	CONNECTOR	ANGLE
3	6	91103	OMLØBER M/SKÆRERING M18	VERSCHRAUBUNG	ADAPTOR	RACCORD
4	1	91040	HYDRAULIK RØR Ø 12 X 90o GALV.	HYDR. ROHR	HYDR. TUBE	TUBE HYDR.
5	3	91004	Lige forskruning M18 x M18	GERADE VERSCHRAUBUNG	STRAIGHT CONNECTION	JOINT DROIT
6	3	91006	T-STYKKE M18X1.5 P-TV 12L	T-STÜCK	T-PIECE	T-PIECE
7	2	91245	DRØVLING Ø1,5	DROSSEL	THROTTLE	GRIVE
8	1	37700	SLANGE M18 L + M 18 L L=2600 MM	SCHLAUCH	HOSE	TUYAU
9	1	37701	SLANGE M18 L + M18 L L=1730 MM	SCHLAUCH	HOSE	TUYAU
10	1	37702	SLANGE M18 L + M18 L L=1240 MM	SCHLAUCH	HOSE	TUYAU
11	1	37703	SLANGE M18 L + M18 L L=2000 MM	SCHLAUCH	HOSE	TUYAU
12	1	37366	ACCUMULATOR HOLDER	ACCUMULATOR HALTERUNG	HOLDER FOR ACCUMULATOR	GARNITURE DE FIXATION
13	4	91028	3/8" BONDED SEALS PAKRING	BONDED SEALS PACKRING	BONDED SEAL WASHER	JOINT BONDED SEALS
14	5	91027	1/4" BONDED SEALS PAKRING	BONDED SEALS PACKRING	BONDED SEAL WASHER	JOINT BONDED SEALS
15	1	91256	MANOMETER 1/4" RG	MANOMETER	MANOMETER	MANOMÈTRE
16	2	91003	BRYSTNIPPEL M18 / 3/8" RG GALV.	VERSCHRAUBUNG	HEXAGON NIPPLE CONNECTOR	RACCORD DE JONCTIONS MÂLES
17	2	91026	M18 BONDED SEALS PAKRING	M18 BONDED SEALS PAKRING	BONDED SEAL WASHED	JOINT BONDED SEALS
18	2	91258	AKKUMULATOR 1 L H1000R - 25 BAR	AKKUMULATOR	ACCUMULATOR	ACCUMULATEUR
19	1	91113	LIGE FORSKR. P-EGES 12 LR-WD-SV	GERADE VERSCHRAUBUNG	STRAIGHT CONNECTION	JOINT DROIT
20	1	27396	PILOTSTYRET KONTRAVENTIL 1/4" - ENKELT	PILOTGESTEUERTES SPERRVENTIL EINFACH	PILOT-OPERATED CHECK VALVE, SINGLE	CLAPET DE BLOCAGE PILOTE SIMPLE
21	1	37704	SLANGE M18 V + M18 L L=2200 MM	SCHLAUCH	HOSE	TUYAU
22	4	91045	LIGE FORSKRUNING M18 x 1/4"	GERADE VERSCHRAUBUNG	STRAIGHT CONNECTION	JOINT DROIT
23	2	37705	SLANGE HAN + M18 V L=5200 MM	SCHLAUCH	HOSE	TUYAU
24	1	37706	SLANGE M18 V + M18 V L=400 MM	SCHLAUCH	HOSE	TUYAU
25	1	37707	SLANGE M18 V + M18 L L=2300 MM	SCHLAUCH	HOSE	TUYAU
26	1	91057	TRANSFERS WARNING/ACHTUNG/VIGTIG	SCHILD	PLATE	PLAQUE
27	1	37690	SKILT TIL MAXIROLL VED MANOMETER	SCHILD	PLATE	PLAQUE
28	1	91089	BRYSTNIPPEL 3/8"MALE 1/4"FEMALE	VERSCHRAUBUNG	HEXAGON NIPPLE CONNECTOR	RACCORD DE JONCTIONS MÂLES

Ekstraudstyr, options, Zusatzausrüstung, Accessoires en option
Crackerboard 950, crackerboard,

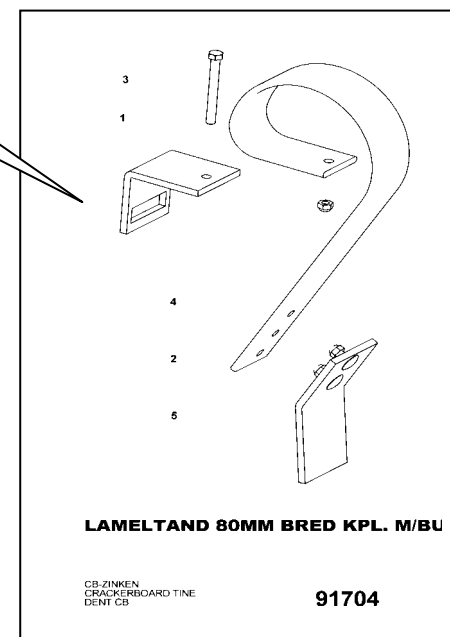
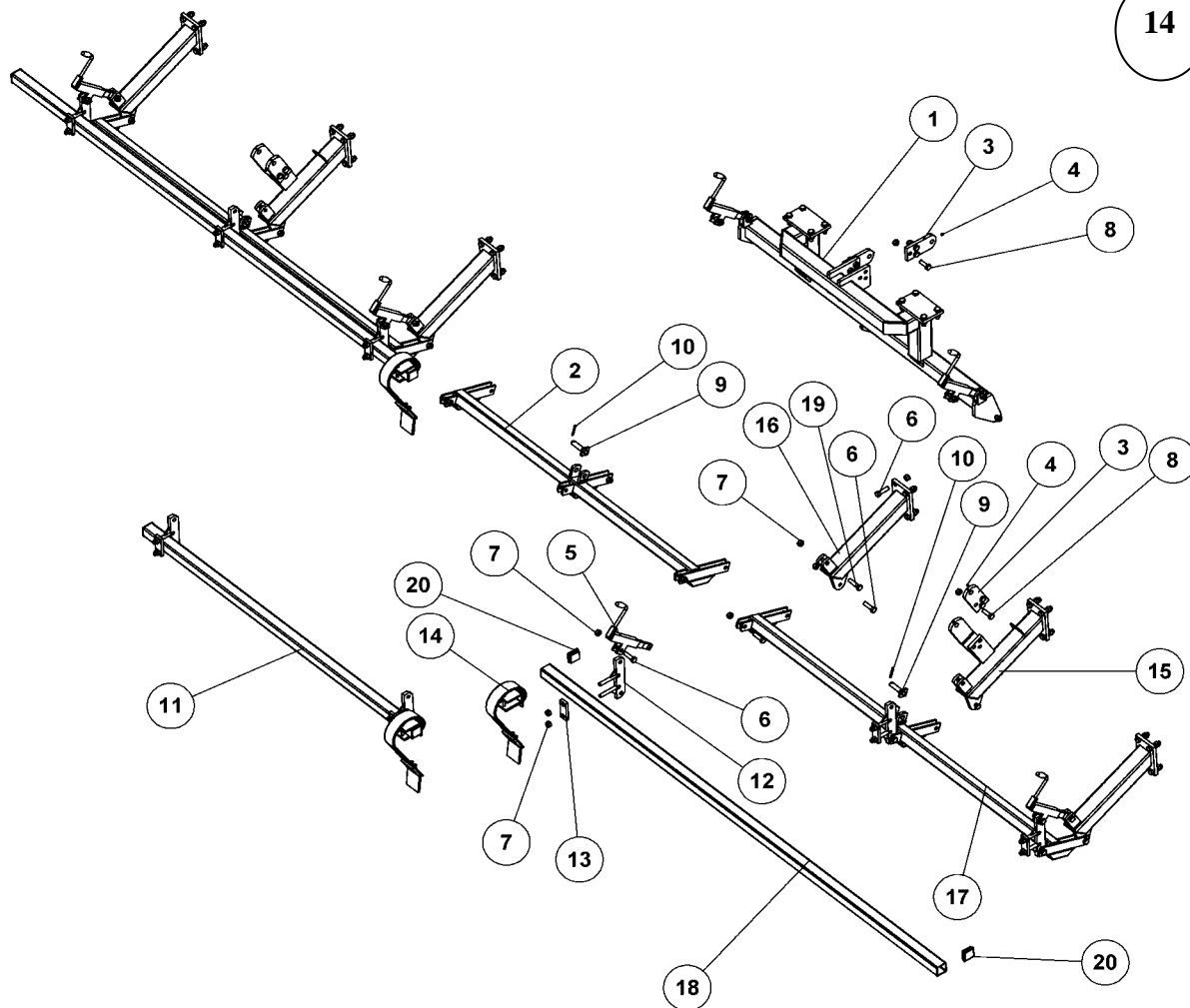

**CRACKERBOARD TIL MINIMAX 950 CM
BUKKET SLIDDEL**

CRACKERBOARD - MITTLERE SEKTION
CRACKERBOARD - CENTER SECTION
CRACKERBOARD SECTION CENTRALE

24161



CRACKERBOARD TIL MINIMAX 950 CM BUKKET SLIDDEL

24161

CRACKERBOARD - MITTLERE SEKTION
CRACKERBOARD - CENTER SECTION
CRACKERBOARD SECTION CENTRALE

Pos.	Qty.	Part nr.	Benævnelse	Bezeichnung	Description	Designation
1	1	37506	FÆSTE FOR STRIGLE - GREENLINE 830 MIDT	BEFESTIGUNG	MOUNTING	FIXATION
2	1	37501	NEDERSTE HÆNGSEL 830 MIDT	UNTERSTES SCHARNIER MITTELSEKTION	BOTTOM HINGE OF MIDDLE SECTION	CHARNIÈRE BAS SECTION CENTRALE
3	4	37907	PLADE TIL CYLINDERFÆSTE - ØVERST	BESCHLAG	MOUNTING PLATE	FIXATION
4	6	90721	SMØRENIPPEL M8x1	SCHMIERNIPPEL	GREASE NIPPLE	GRAISSEUR
5	6	91695	SPINDEL NR. 1 - FÆSTE BUND/MIDT	SPINDEL	SPINDLE	FUSEAU
6	49	92342	BOLT 20x70 8.8 GALV.	SCHRAUBE	SCREW	BOULON
7	89	92052	MØTRIK M 20 SELVLÅS. GALV. 8	MUTTER SELBSTGESICHERT	SELF-LOCKING NUT	ÉCROU DE SÉCURITÉ
8	20	92334	BOLT 20x60 8.8 GALV.	SCHRAUBE	SCREW	BOULON
9	3	72275	NAGLE F. Ø25X85(113)	BOLZEN	PIN	AXE
10	3	90677	SPLIT 8X50 MM GALV.	SPLINT	SPLIT PIN	GOUPILLE
11	1	93030233090L90L	KIRK-RØR 70X70X4 - 2330 MM	VIERKANT ROHR	SQUARE TUBE	TUBE CARRÉ
12	8	37350	TANDHOLDER Ø20	ZINKENHALTER	TINE MOUNT	SUPPORT DE DENTS
13	8	37680	SPÆNDEPLADE Ø21-71-50X15	PLATTE	FASTENING PLATE	PLAQUE
14	51	91704	LAMELTAND 80MM BRED KPL.	CB-ZINKEN KPL. MIT SPITZE	CB - TINE CPL. WITH POINT	DENT DE HERSE ARRIÈRE COURTE AVEC POINTE COURBÉE
15	2	37503	ARM TIL STRIGLE M. CYLINDERFÆSTE	ARM_RECHTS	ARM, RIGHT	BRAS_DROITE
16	4	37381	ARM TIL LAMELPLANKE U/CYLINDER	ARM	ARM	BRAS
17	2	23509	NEDERSTE HÆNGSEL SIDE	UNTERSTES SCHARNIER	BOTTOM HINGE	CHARNIÈRE BAS SECTION
18	2	37295	TANDSTANG 950	ZINKENHALTER STARR	TINE BAR, RIGID	PORTE-DENTS RIGIDE
19	4	92336	BOLT 20 X 80 8.8 GALV.	SCHRAUBE	SCREW	BOULON
20	6	90766	DUPSKO RHS 70X70 - 2-4	RÖHRENSTÖPSEL	END CAP	BOUCHON DE TUBE



LAMELTAND 80MM BRED KPL. M/BUK SPIDS

91704

CB-ZINKEN
CRACKERBOARD TINE
DENT CB

Pos.	Qty.	Part nr.	Benævnelse	Bezeichnung	Description	Designation
1	1	91721	SPÆNDESTYKKE 10 MM TIL 80 MM TAND	SPANNSTÜCK	PLATE	PIÈCE DE SERRAGE
2	1	91707	LAMELTAND LANG 3 HULS 80MM BRED	CB-ZINKEN	CB - TINE	DENT DE CB
3	1	92303	BOLT 12x110 8.8 GALV.	SCHRAUBE	SCREW	BOULON
4	1	92050	MØTRIK M12 SELVLÅS. GLV. 8	MUTTER SELBSTSCHLIESSEND	SELFLOCKING NUT	ÉCROU DE SÉCURITÉ
5	1	91730	SLIDDEL 100X10 BUK kompl. M. BOLTE	SPTTZE GEBEUGT M. BOLZEN	CB POINT WITH SCREWS	POINT AVEC BOULONS.

CRACKERBOARD TIL MINIMAX 1030 CM

BUKKET SLIDDEL

24192

Pos.	Qty.	Part nr.	Benævnelse	Bezeichnung	Description	Designation
14	55	91704	LAMELTAND 80 MM BRED KPL.	CB-ZINKEN KPL. MIT SPITZE	CB - TINE CPL. WITH POINT	DENT DE HERSE ARRIÈRE COURTE
18	2	37308	TANDSTANG 1030	ZINKENHALTER STARR	TINE BAR, RIGID	PORTE-DENTS RIGIDE

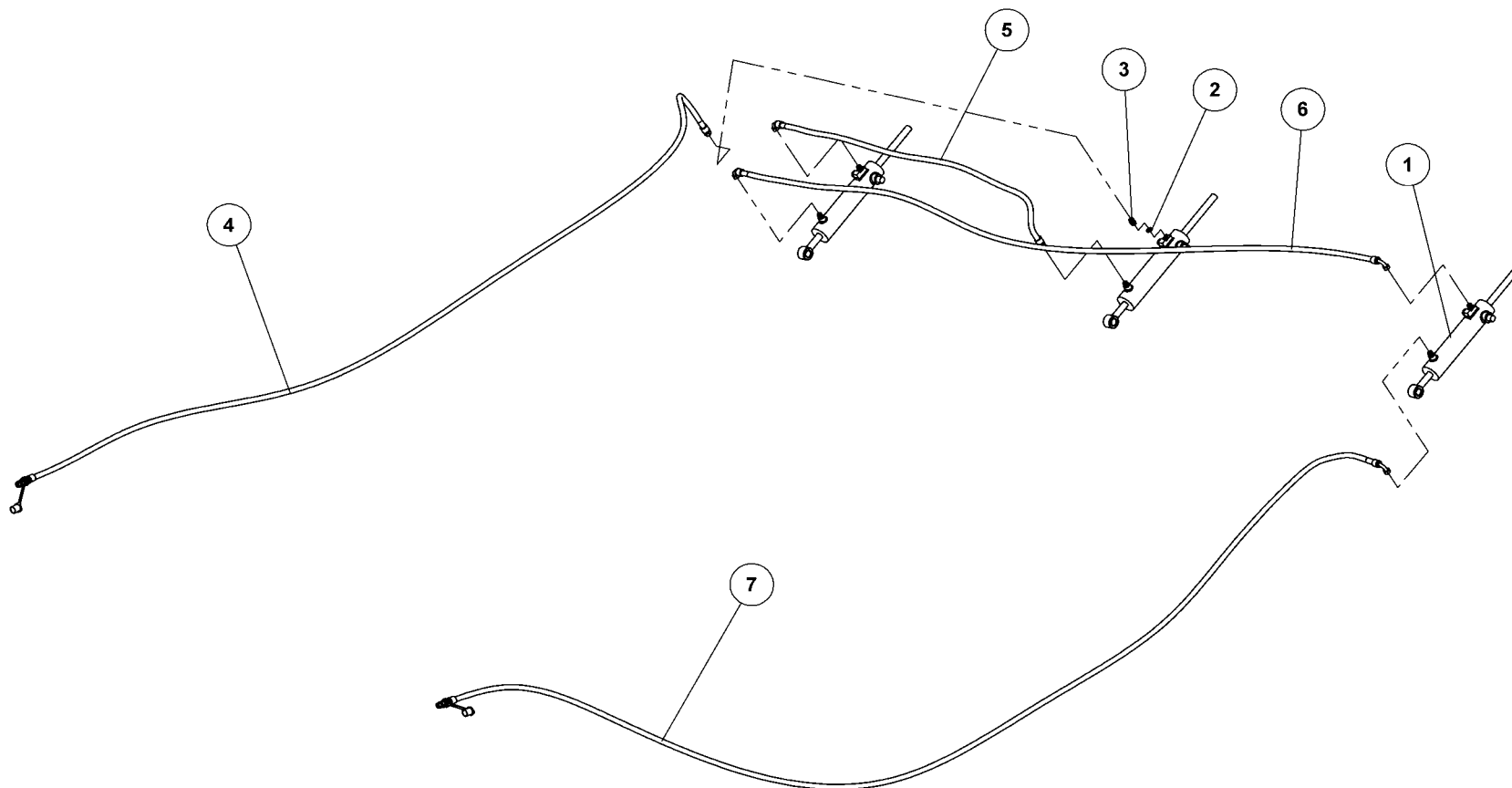

**HYDRAULIK T/ LAMELPLANKE
GREENLINE 830**

HYDRAULIK
HYDRAULIC
HYDRAULIQUE

37711



HYDRAULIK T/ LAMELPLANKE

GREENLINE 830

37711

HYDRAULIK
HYDRAULIC
HYDRAULIQUE

Pos.	Qty.	Part nr.	Benævnelse	Bezeichnung	Description	Designation
1	3	91792	CYLINDER 25X60X25X205	ZYLINDER	RAN	VERRIN
2	6	91028	3/8" BONDED SEALS PAKRING	BONDED SEALS PAKRING	BONDED SEAL WASHER	JOINT BONDED SEALS
3	6	91003	BRYSTNIPPEL M18 / 3/8" RG GALV.	VERSCHRAUBUNG	HEXAGON NIPPLE CONNECTOR	RACCORD DE JONCTIONS MÂLES
4	1	37712	SLANGE HAN + M18 L L=6000 MM	SCHLAUCH	HOSE	TUYAU
5	1	37713	SLANGE M18 V + M18 L L=5100 MM	SCHLAUCH	HOSE	TUYAU
6	1	37714	SLANGE M18 V + M18 V L=6000 MM	SCHLAUCH	HOSE	TUYAU
7	1	37715	SLANGE HAN + M18 V L=10400 MM	SCHLAUCH	HOSE	TUYAU

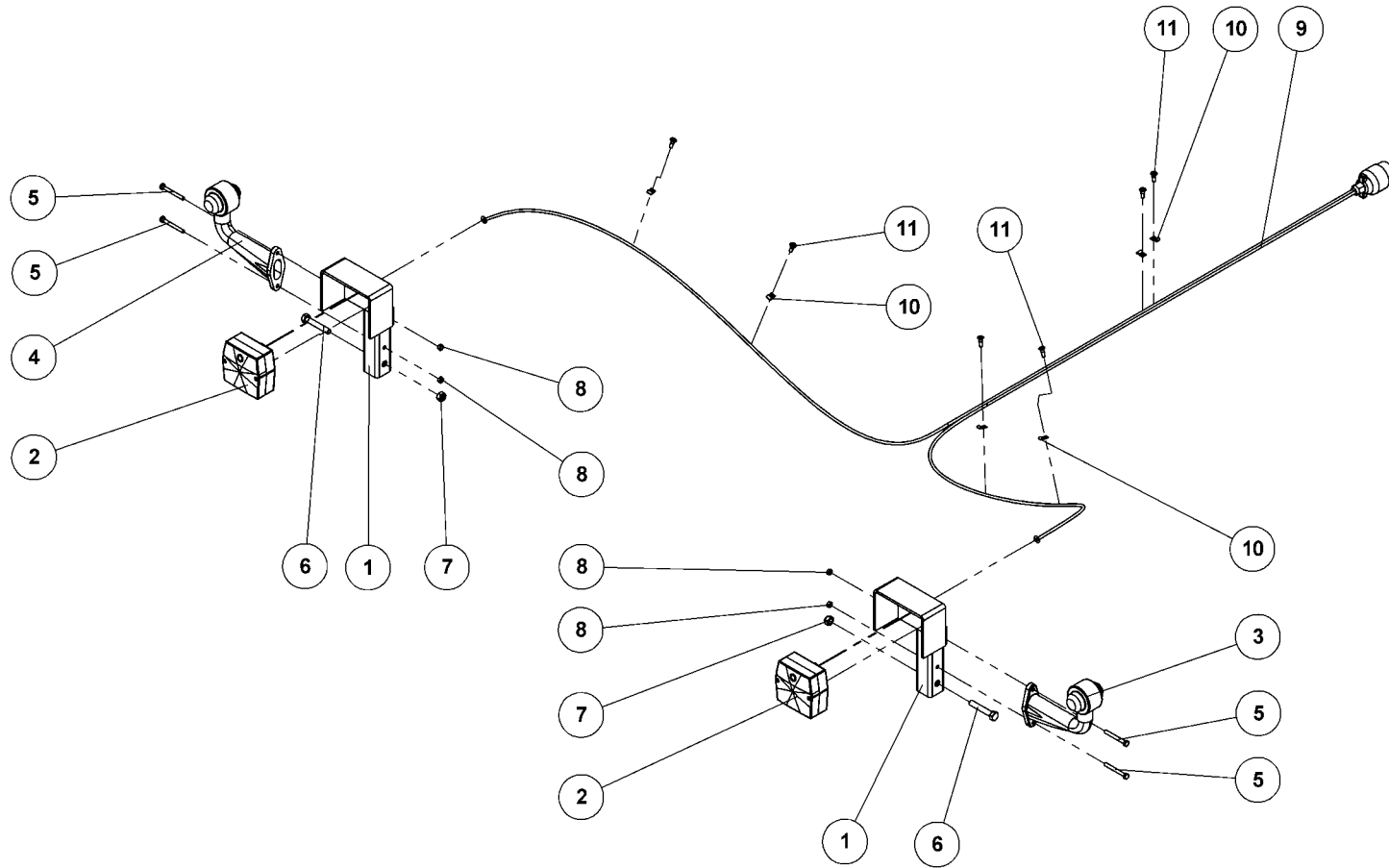

LYGTESÆT 530/630/730

LEUCHTSSATZ
LIGHT SET
ENSEMBLE DE PHARES

37186



LYGTESÆT 530/630/730

37186

LEUCHTSSATZ
LIGHT SET
ENSEMBLE DE PHARES

Pos.	Qty.	Part nr.	Benævnelse	Bezeichnung	Description	Designation
1	2	71454	LYGTESTANDER FÆLLES	LEUCHTSTÄNDER	LIGHT STAND	BÂTON DES LUMIÈRES
2	2	89400	BAGLYGTE MINIPPOINT U/NR.PL.LYS	RÜCKLICHT	MINIPPOINT BACKLIGHTS W/OUT LICENSE PLATE LIGHT	PHARE ARRIÈRE
3	1	89416	MARKERINGSLYS HØJRE 0,25M. BAJONET	LEUCHE RECHTS	MARKING LIGHTS, RIGHT	LUMIÈRE DE SIGNALISATION DROITE
4	1	89415	MARKERINGSLYS VENSTRE 0,25M. BAJONET	LEUCHE LINKS	MARKING LIGHTS, LEFT	LUMIÈRE DE SIGNALISATION GAUCHE
5	4	92253	BOLT 6x55 8.8 GALV.	SCHRAUBE	SCREW	BOULON
6	2	92277	BOLT 10x60 8.8 GALV.	SCHRAUBE	SCREW	BOULON
7	2	92049	MØTRIK M10 SELVLÅS. GLV.8	MUTTER	SELF-LOCKING NUT	ÉCROU
8	4	92027	MØTRIK M6 GALV. kl.8	MUTTER	NUT	ÉCROU
9	1	89430	KABELSÆT 2x7M - 7-POL STIK	KABELSATZ	CABLE ASSEMBLY	ENSEMBLE DE CÂBLES
10	6	88146	KABELBØJLER 5 mm	KABELHALTER	CABLE BRACKET	COLLIER DE CÂBLE
11	6	92401	GALOPSKRUE PZD. L/H 4.8 x 16	TAPTITE	TAPTITE	TAPTITE

LYGTESÆT 950/1030

37187

Pos.	Qty.	Part nr.	Benævnelse	Bezeichnung	Description	Designation
9	1	89431	KABELSÆT 2x9M-7POLSTIK	KABELSATZ	CABLE ASSEMBLY	ENSEMBLE DE CABLES

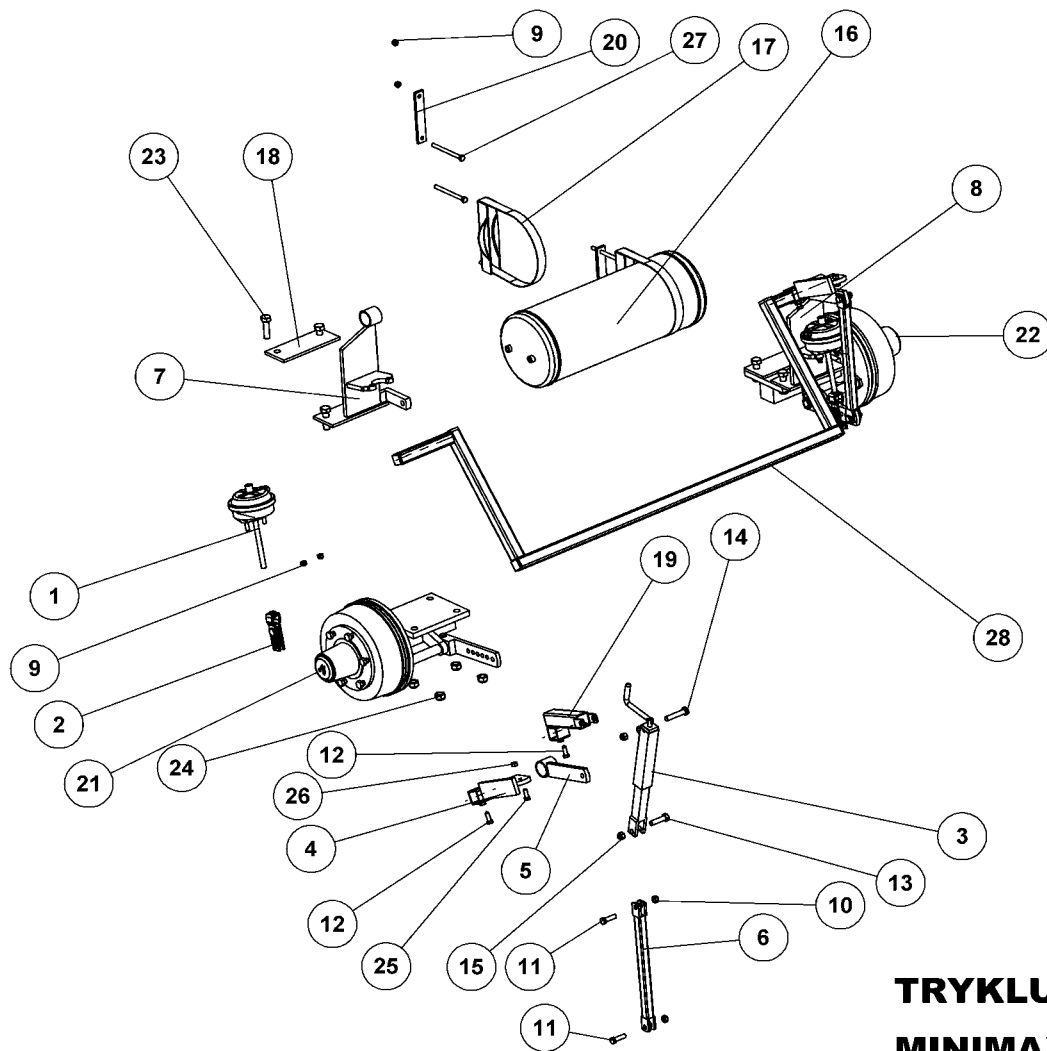

**TRYKLUFTBREMSE
MINIMAX 950/1030**

BREMSE
BRAKES
FREIN

37196



TRYKLUFTBREMSE

MINIMAX 950/1030

37196

BREMSE
BRAKES
FREIN

Pos.	Qty.	Part nr.	Benævnelse	Bezeichnung	Description	Designation
1	2	88204	MEMBRANCYLINDER 16"	MEMBRANZYLINDER	MEMBRANE CYLINDER	CYLINDRE À MEMBRANE
2	2	88206	MONTERINGSSÆT LANG GAFFEL	MONTAGESATZ LANGE GABEL	MOUNTING SET, LONG FORK	ENSEMBLE DE MONTAGE FOURCHE LONGUE
3	1	21465	SPINDEL SHF 6-01	SPINDEL	SPINDLE	FUSEAU
4	2	37785	JUSTERBAR BREMSENØGLE KOMPLET	BREMSARM	BRAKE ARM FOR BRAKE LEVER	BRAS DE FREIN POUR BÂTON DE FREIN
5	2	37784	BREMSENØGLE MED RUND RØR	BREMSARM	BRAKE ARM FOR BRAKE LEVER	BRAS DE FREIN POUR BÂTON DE FREIN
6	2	37782	FORBINDELSESTANG HÅNDBREMSE	VERBINDUNGSSTANGE	CONNECTING LINK	BRAS DE CONNEXION
7	1	37787	BREMSEHOLDER VENSTRE	BREMSE HALTERUNG, LINKS	BRAKE MOUNT, LEFT	SUPPORT DE FREIN, GOUCHE
8	1	37788	BREMSEHOLDER HØJRE	BREMSE HALTERUNG, RECHTS	BRAKE MOUNT, RIGHT	SUPPORT DE FREIN, DROITE
9	8	92050	MØTRIK M12 SELVLÅS, GLV. 8	MUTTER SELBSTSCHLIESSEND	SELF-LOCKING NUT	ÉCROU DE SÉCURITÉ
10	4	92034	MØTRIK M14 SELVLÅS, GLV. 8	MUTTER	SELF-LOCKING NUT	ÉCROU
11	4	92362	BOLT 14X50 8.8 GLV.	SCHRAUBE	SCREW	BOULON
12	3	92383	BOLT 12x35 GALV. 8.8 (STOPRINGSBOLT)	SCHRAUBE	COLLAR SCREW	BOULON
13	1	92318	BOLT 16x60 8.8 GALV.	SCHRAUBE	SCREW	BOULON
14	1	92320	BOLT 16x80 8.8 GALV.	SCHRAUBE	SCREW	BOULON
15	2	92051	MØTRIK M16 SELVLÅS, GLV. 8	MUTTER	SELF-LOCKING NUT	ÉCROU
16	1	88210	BEHOLDER 40 Ltr. Std. 640	BEHÄLTER	RÉSERVOIR	RÉSERVOIR
17	2	88211	LUFTBEHOLDEROPH. F/40L - 276 MM	LUFTBEHÄLTERAUFHÄNGUNG	AIR RESERVE TANK MOUNTING BRACKET/BRACKET	SUSPENSION DU RÉSERVOIR À AIR
18	2	37791	BREMSEFÆSTE TIL MAXIROLL	PLATTE	FASTENING PLATE	PLAQUE
19	1	37783	BREMSENØGLE FOR SPINDEL	BREMSSTANGE	BRAKE LEVER	BÂTON DE FREIN
20	2	37793	SPÆNDEPLADE Ø12-165 35X8-200	PLATTE	FASTENING PLATE	PLAQUE
21	1	25227	LUFTBREMSENAV M. FLANGE VENSTRE	BREMSNABE	BRAKE HUB	MOYEU DE FREIN/GOUPILLE
22	1	25228	LUFTBREMSENAV M. FLANGE HØJRE	BREMSNABE RECHTS	BRAKE HUB RIGHT	MOYEU DE FREIN/GOUPILLE GAUCHE DROITE
23	8	92342	BOLT 20x70 8.8 GALV.	SCHRAUBE	SCREW	BOULON
24	8	92052	MØTRIK M 20 SELVLÅS, GALV. 8	MUTTER SELBSTGESICHERT	SELF-LOCKING NUT	ÉCROU DE SÉCURITÉ
25	2	92295	BOLT 12x30 8.8 GALV. (SÆTBOLT)	SCHRAUBE	SET SCREW	BOULON
26	2	92030	MØTRIK M12 GALV. KI.8	MUTTER	NUT	ÉCROU
27	4	92305	BOLT 12x150 8.8 GALV.	SCHRAUBE	SCREW	BOULON
28	1	37528	FORBINDELSERØR 40X40X4	VERBINDUNGSSTANGE	CONNECTING LINK	BRAS DE CONNEXION

TRYKLUFTBREMSE MINIMAX 950/1030 12" MEMBRAN

37195

Pos.	Qty.	Part nr.	Benævnelse	Bezeichnung	Description	Designation
1	2	88203	MEMBRANCYLINDER 12"	MEMBRANZYLINDER	MEMBRANE CYLINDER	CYLINDRE A MEMBRANE