

DALBO®

**Reservedele
Spareparts
Ersatzteile
Pieces**

MEGAROLL
2130 & 2430 cm
Serie no. 104937 – XXXXXX

MADE IN  DENMARK

Indholdsfortegnelse,

Table of Contents, Inhaltsverzeichnis, Table des matières

RESERVEDELSLISTENS OPBYGNING, THE CONSTRUCTION OF THE SPAREPARTSLIST	5
MEGAROLL 2430.....	6
KOMPLET MIDTERSEKTION, MITTLERE SEKTION, MIDDLE SECTION, SECTION CENTRALE	8
KOMPLET HØJRE SEKTION, SEITENSEKTION RECHTS, SIDE SEKTION RIGHT, SECTION LATÉRALE DROITE	10
SÆT GODS PÅ AKSLER 2430 x 55 CM CAMBRIGE, GIESSGUT AUF WELLEN, METAL ON SHAFTS, METAL SUR ARBRES	12
GODS PÅ AKSEL 3 MIDTERSTE AKSLER, SATZ GIESSGUT FÜR DIE WELLEN, METAL SET FOR AXLE, METAL SUR ARBRES	14
GODS PÅ AKSEL – SIDER, SATZ GIESSGUT FÜR DIE WELLEN, METAL SET FOR AXLE, METAL SUR ARBRES	16
LYGTESÆT, LEUCHTSATZ, LIGHT SET, ENSEMBLE DE PHARES	18
HYDR. FOR EL-STYRING, ELEKTR. HYDR. STEUERRING, EL-HYDR. CONTROL, ANNEAU DE CONTRÔLE EL. HYDR.	20
HYDRAULISK AFFJEDRING, HYDRAULISCHES STEINAUSLOSER, HYDR. STONE SAFETY RELEASE, DISPOSITIF DE RELACHE DE PIERRE HYDR.....	22
HYDR. HYDRAULISK STØTTEBEN, STUTZFUSS, JACK, BEQUILLE	24
VIPPECYLINDER, KLIPPZYLINDER, TILTING CYLINDER, VERRIN DE BASCULEMENT	26
HYDR. LØFT/SÆNK BAGERSTE TROMLESEKTION, HYDRAULIK, HYDRAULIC, HYDRAULIQUE	28
HYDR. UDKLAP YDERSTE SEKTIONER, HYDRAULIK, HYDRAULIC, HYDRAULIQUE	30
HYDR. UDKLAP OG VÆGTOVERFØRING SIDER, HYDRAULIK, HYDRAULIC, HYDRAULIQUE.....	32
HYDR. VÆGTOVERFØRING YDERST, HYDRAULIK, HYDRAULIC, HYDRAULIQUE	34

Reservedelslistens opbygning, the construction of the sparepartslist

<p>For deres sikkerhed samt for funktionsdygtigheden af deres maskine, bør der kun anvendes originale DALBO reservedele til deres maskine</p> <p>Når de bestiller reservedele bør de altid informere om:</p> <ul style="list-style-type: none"> • Reservedelsnummer • Maskinens typenummer • Antal styk af reservedelen 	<p>For your safety and for the functions of the mashing, you should only use original spare parts for m DALBO.</p> <p>When you order spare parts, you should always inform about:</p> <ul style="list-style-type: none"> • Spare part number • The mashing type number • Amount of spare parts pieces 	<p>Zu Ihrer Sicherheit und zur einwandfreien Funktion ihres Gerätes sollten sie unbedingt nur original DALBO Ersatzteile verwenden.</p> <p>Wenn sie Ersatzteile bestellen bitte folgendes beachten:</p> <ul style="list-style-type: none"> • Ersatzteil-Nummer • Geräte-Nummer und -typ • Anzahl der Ersatzteile 	<p>Pour votre sécurité et pour les fonctions du matériel, vous devez utiliser uniquement des pièces détachées d'origine DALBO.</p> <p>Lorsque vous commandez vos pièces détachées, vous devez toujours nous indiquer :</p> <ul style="list-style-type: none"> • Le numéro de la pièce • Le type de la machine • La quantité des pièces détachées.
--	--	---	--

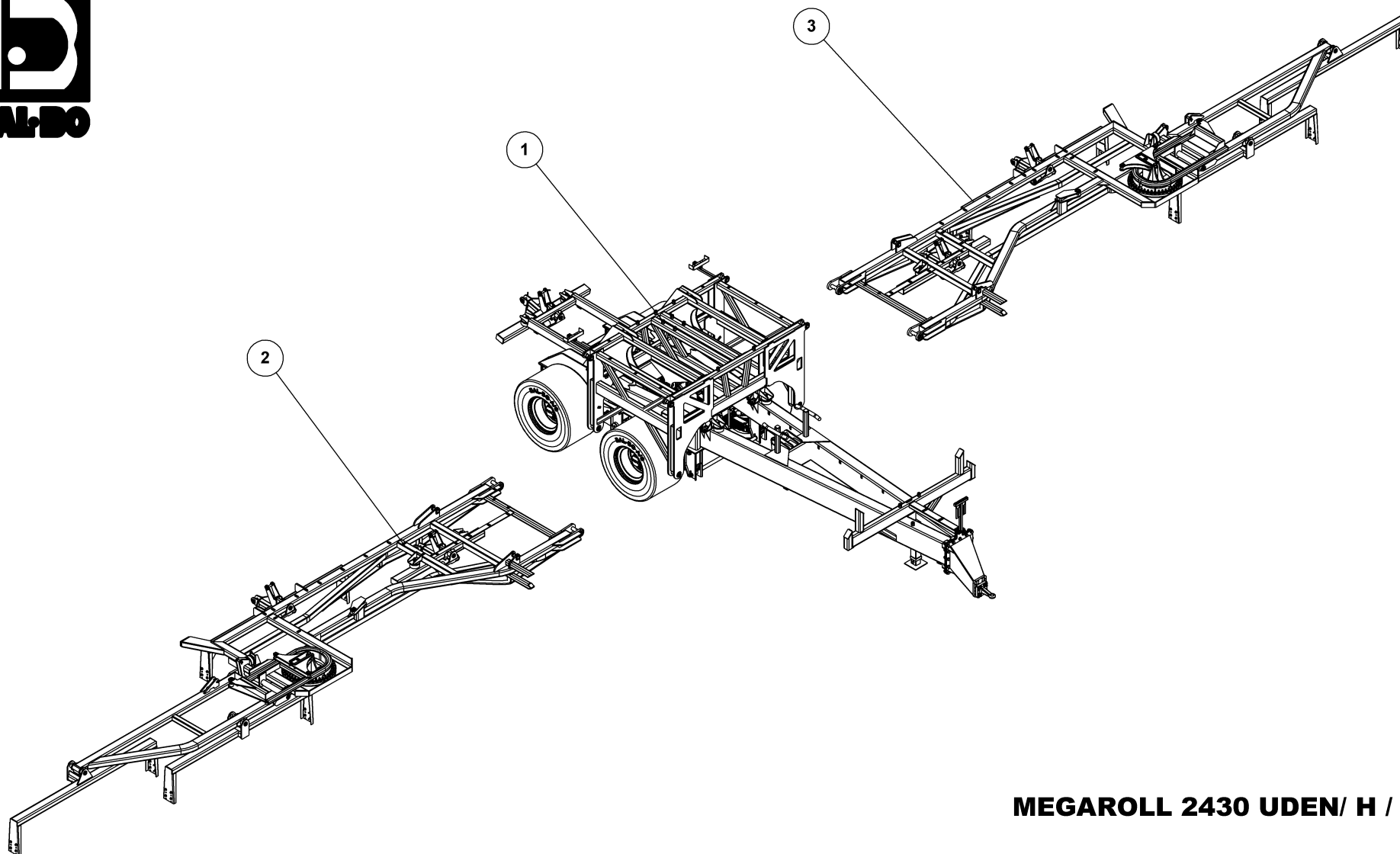

MEGAROLL 2430 UDEN/ H / G

63200



MEGAROLL 2430 UDEN/ H / G

63200

Pos.	Qty.	Part nr.	Benævnelse	Bezeichnung	Description	Designation
1	1	63195	KOMPLET MIDTERSEKTION U/H/GODS	MITTLERE SEKTION	MIDDLE SECTION	SECTION CENTRALE
2	1	63196	KOMPLET HØJRE SEKTION U/H/GODS	SEITENSEKTION RECHTS	SIDE SEKTION RIGHT	SECTION LATÉRALE DROITE
3	1	63197	KOMPLET VENSTRE SEKTION U/H/GODS	SEITENSEKTION LINKS	SIDE SEKTION LEFT	SECTION LATÉRALE GAUCHE

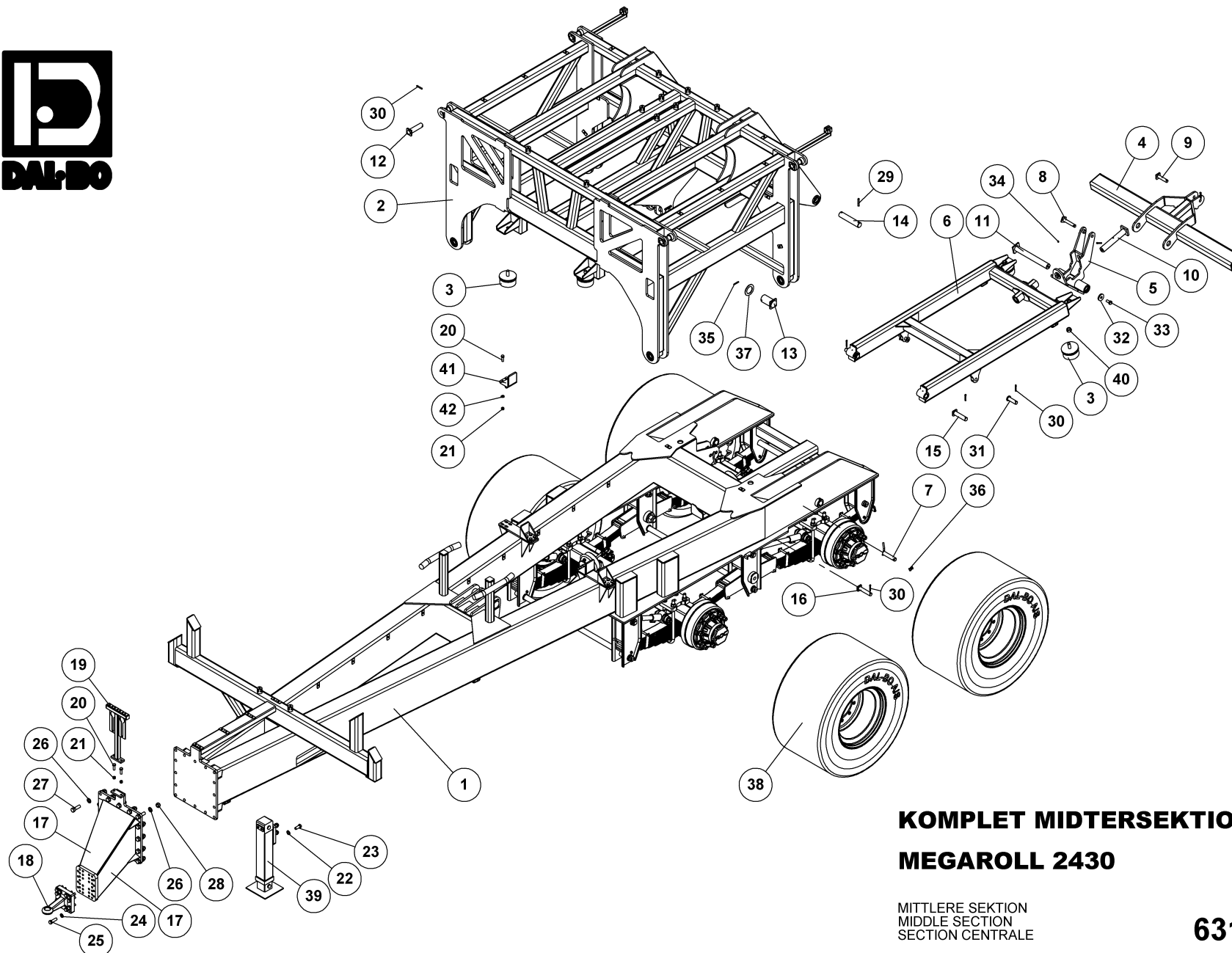

**KOMPLET MIDTERSEKTION U/H/GODS
MEGAROLL 2430**

MITTLERE SEKTION
MIDDLE SECTION
SECTION CENTRALE

63195



KOMPLET MIDTERSEKTION U/H/GODS MEGAROLL 2430

63195

MITTLERE SEKTION
MIDDLE SECTION
SECTION CENTRALE

Pos.	Qty.	Part nr.	Benævnelse	Bezeichnung	Description	Designation
1	1	63213	HOVEDRAMME - 2430	HAUPTRAHMEN	MAIN FRAME	CHASSIS
2	1	63214	MIDTERRAMME - MEGAROLL 2430	MITTELRAHMEN	MID FRAME	CADRE CENT.
3	4	85430	GUMMIDÆMPEL 148X60. M24	GUMMIKLOTZ	RUBBER BLOCK	BLOC EN CAOUTCHOUC
4	1	63220	PENDLERRAMME MIDT - 2430	RAHME	FRAME	CADRE
5	1	33479	3D DREJEHOVED	DREHKOPF	TURNING HEAD PIECE	TÊTE TOURNANTE
6	1	63219	ARM FOR GODS - BAG	ARM	ARM	BRAS
7	2	78937	NAGLE F Ø32X150 MM KAT 3	BOLZEN	PIN	AXE
8	1	71386	NAGLE F Ø25X130(158)	BOLZEN	PIN	AXE
9	1	74318	NAGLE F Ø25X100(128)	BOLZEN	PIN	AXE
10	1	33485	NAGLE F Ø50X298	BOLZEN	PIN	AXE
11	1	74306	NAGLE F Ø50X413(428)M20 ind.	BOLZEN	PIN	AXE
12	4	38506	NAGLE F Ø40X140 MM	BOLZEN	PIN	AXE
13	4	63211	NAGLE F Ø70X106	BOLZEN	PIN	AXE
14	2	78321	NAGLE FOR HYDR. STILK	BOLZEN	PIN	AXE
15	2	80469	NAGLE F Ø35X130(158)	BOLZEN	PIN	AXE
16	2	71387	NAGLE F Ø30X130(158)	BOLZEN	PIN	AXE
17	1	63228	TRÆKFORLÆNGER 2430 - 4500 KG	ZUG VERLÄNGERUNG	DRAWBAR EXTENSION	ALLONGEMENT D'ATTELAGE
18	1	25229	SCHARMÜLLER HITCH - 4000 KG	SCHARMÜLLER HITCH	DRAWBAR EYE	CROCHET D'ATTELAGE
19	1	63225	SLANGEHOLDER - 2430	HALTER	BRACKET	SUPPORT
20	18	92317	BOLT 16X50 MM 8.8 GALV.	SCHRAUBE	SCREW	BOULON
21	18	92051	MØTRIK M16, SELVLÅS. GALV. KV. 8.8	MUTTER	NUT	ÉCROU
22	6	90664	SPÆND. SKIVE Ø39 X Ø23 X 3	UNTERLEGSCHLEIBE	SEALING WASHER	RONDELLE DE SERRAGE
23	6	92335	BOLT 20x50 8.8 GALV. (SÆTBOLT)	SCHRAUBE	SET SCREW	BOULON
24	12	90671	SKIVE Ø21-Ø37-3	UNTERLEGSCHLEIBE	WASHER	RONDELLE DE SERRAGE
25	12	92342	BOLT M20X70 MM 8.8 GALV.	SCHRAUBE	SCREW	BOULON
26	32	90670	SKIVE Ø25-Ø44-4	UNTERLEGSCHLEIBE	WASHER	RONDELLE DE SERRAGE
27	16	92351	BOLT 24x80 8.8 GALV.	SCHRAUBE	SCREW	BOULON
28	16	92053	MØTRIK M24, SELVLÅS. GALV. KV. 8.8	MUTTER	SELF-LOCKING NUT	ÉCROU
29	4	90745	RØRSTIFT Ø12X80	ROHRSTIFT	SPLIT PIN	AXE TUBULAIRE
30	12	90677	SPLIT 8X50 MM GALV.	SPLIT	SPLIT PIN	GOUPILLE
31	2	90448	NAGLE R Ø30 X 85(100)	BOLZEN	PIN	AXE
32	2	74529	SKIVE Ø21-Ø69-10	UNTERLEGSCHLEIBE	WASHER	RONDELLE DE SERRAGE
33	2	92349	BOLT 20x40 8.8 GALV. (SÆTBOLT)	SCHRAUBE	SCREW	BOULON
34	6	90721	SMØRENIPPPEL LIGE M8x1 MM	SCHMIERNIPPPEL	GREASE NIPPLE	GRAISSEUR
35	4	90764	RØRSTIFT Ø 8X60 MM	ROHRSTIFT	SPLIT PIN	AXE TUBULAIRE
36	2	90680	RINGSPLIT Ø 8X40 FLAD	RINGSPLIT	LINCH PIN	GOUPILLE
37	4	63611	SKIVE Ø71/Ø110 X 4 MM GALV.	SCHLEIBE	WASHER	RONDELLE
38	4	80040	HJUL KPL. 600/50-22,5 MICHELIN CAR X BIB	RAD	WHEEL	ROUE
39	1	63302	HYDR. HYDRAULISK STØTTEBEN	STÜTZFUSS	JACK	BÉQUILLE
40	2	92033	MØTRIK M24, GALV. KV. 8.8	MUTTER	NUT	ÉCROU
41	4	63621	STOP KPL. FOR MIDTERRAMME	ANSCHLAG	STOP BLOCK	BLOC D'ARRÊT
42	16	90175	SKIVE M16, Ø17X30X4 - HÆRDET	UNTERLEGSCHLEIBE	WASHER	RONDELLE DE SERRAGE

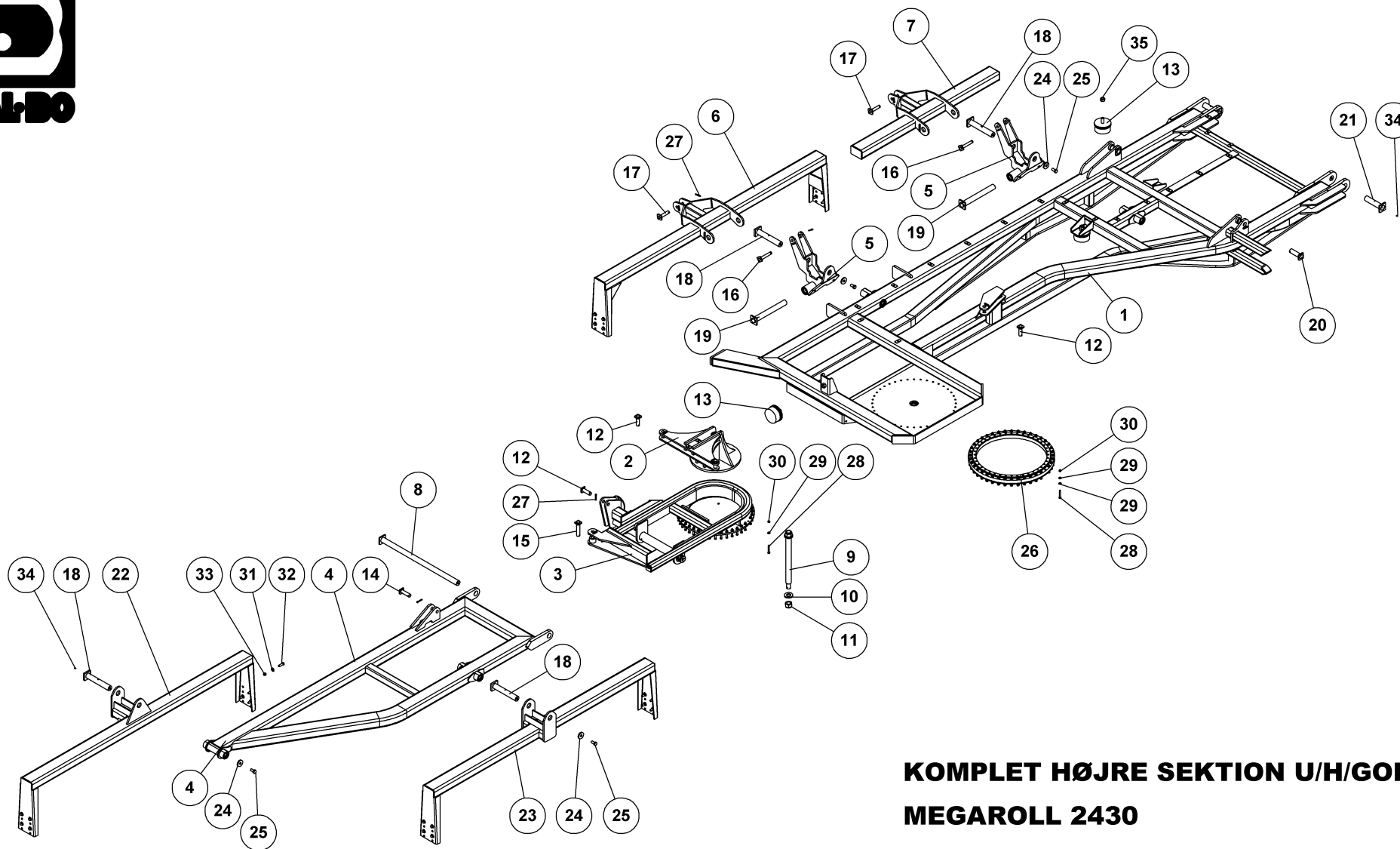

**KOMPLET HØJRE SEKTION U/H/GODS
MEGAROLL 2430**

SEITENSEKTION RECHTS
SIDE SEKTION RIGHT
SECTION LATERALE DROITE

63196



KOMPLET HØJRE SEKTION U/H/GODS MEGAROLL 2430

63196

SEITENSEKTION RECHTS
SIDE SEKTION RIGHT
SECTION LATÉRALE DROITE

Pos.	Qty.	Part nr.	Benævnelse	Bezeichnung	Description	Designation
1	1	63217	SIDERAMME HØJRE - 2430	SEITENRAHMEN RECHTS	SIDE FRAME, RIGHT	CADRE LATÉRAL DROITE
2	1	63206	SVINGARM FOR UDKLAP	MOBILARM	MOBILEARM	BRAS MOBILE
3	1	63201	UDLIGGERRAMME - HØJRE	RAHME, RECHTS	FRAME, RIGHT	CADRE, DROITE
4	1	63218	SIDERAMME YDERST - HØJRE	SEITENSEKTION RECHTS	SIDE SEKTION RIGHT	SECTION LATÉRALE DROITE
5	2	33479	3D DREJEHOVED	DREHKOPF	TURNING HEAD PIECE	TÊTE TOURNANTE
6	1	33484	PENDLERRAMME SIDE - 1230	RAHME	FRAME	CADRE
7	1	63220	PENDLERRAMME MIDT - 2430	RAHME	FRAME	CADRE
8	1	63551	NAGLE F Ø50X1010(1025)M20	BOLZEN	PIN	AXE
9	1	33259	NAGLE FOR MAXICUT SPECIEL	BOLZEN	PIN	AXE
10	2	33247	TOPSKIVE TIL CENTERNAGLE	SCHLEIBE	WASHER	RONDELLE
11	2	72384	KRONEMØTRIK M39X3, NV 60 GALV. KV. 8.8	ACHSENMUTTER	SHAFT NUT	ÉCROU D'ARBRE
12	4	71384	NAGLE F Ø30X80(108)	BOLZEN	PIN	AXE
13	3	85430	GUMMIDÆMPER 148X60, M24	GUMMIKLOTZ	RUBBER BLOCK	BLOC EN CAOUTCHOUC
14	1	44355	NAGLE F Ø30X90(120)	BOLZEN	PIN	AXE
15	1	71387	NAGLE F Ø30X130(158)	BOLZEN	PIN	AXE
16	2	71386	NAGLE F Ø25X130(158)	BOLZEN	PIN	AXE
17	2	74318	NAGLE F Ø25X100(128)	BOLZEN	PIN	AXE
18	4	33485	NAGLE F Ø50X298	BOLZEN	PIN	AXE
19	2	74306	NAGLE F Ø50X413(428)M20 ind.	BOLZEN	PIN	AXE
20	2	37363	NAGLE F Ø40X115 (143)	BOLZEN	PIN	AXE
21	2	33480	NAGLE F Ø50X210(223)S 33480	BOLZEN	PIN	AXE
22	1	63222	PENDLERRAMME YDERST - 2430	RAHME	FRAME	CADRE
23	1	63223	PENDLERRAMME 2 OG 8 - 2430	RAHME	FRAME	CADRE
24	9	74529	SKIVE Ø21-Ø69-10	UNTERLEGSCHLEIBE	WASHER	RONDELLE DE SERRAGE
25	9	92349	BOLT 20x40 8.8 GALV. (SÆTBOLT)	SCHRAUBE	SCREW	BOULON
26	1	63609	DREJEKRANS, KUGLELEJER, Ø741	DREHKOPF	TURNING HEAD PIECE	TÊTE TOURNANTE
27	12	90677	SPLIT 8X50 MM GALV.	SPLINT	SPLIT PIN	GOUPILLE.
28	80	92300	BOLT 12x80 8.8 GALV.	SCHRAUBE	SCREW	BOULON
29	120	90483	SP. SKIVE M12 Ø24/13X3 HÆRDET GLV.	UNTERLEGSCHLEIBE	WASHER	RONDELLE DE SERRAGE
30	80	92050	MØTRIK M12, SELVLÅS, GALV. KV. 8.8	MUTTER SELBSTSCHLIESSEND	SELFLOCKING NUT	ÉCROU DE SÉCURITÉ
31	48	90663	SKIVE Ø17/Ø35X2 MM	SCHLEIBE	WASHER	RONDELLE
32	24	92317	BOLT 16X50 MM 8.8 GALV.	SCHRAUBE	SCREW	BOULON
33	24	92051	MØTRIK M16, SELVLÅS, GALV. KV. 8.8	MUTTER	NUT	ÉCROU
34	11	90721	SMØRENIPPEL LIGE M6x1 MM	SCHMIERNIPPEL	GREASE NIPPLE	GRAISSEUR
35	2	92033	MØTRIK M24, GALV. KV. 8.8	MUTTER	NUT	ÉCROU

KOMPLET VENSTRE SEKTION U/H/GODS MEGAROLL 2430

Seitensektion links, Side sektion left, Section laterale gauche

63197

Pos.	Qty.	Part nr.	Benævnelse	Bezeichnung	Description	Designation
1	1	63215	SIDERAMME VENSTRE - 2430	SEITENRAHMEN LINKS	SIDE FRAME LEFT	CADRE LATÉRAL GAUCHE
3	1	63210	UDLIGGERRAMME - VENSTRE	RAHME, LINKS	FRAME, LEFT	CADRE, GAUCHE
4	1	63216	SIDERAMME YDERST - VENSTRE	SEITENRAHMEN LINKS	SIDE FRAME LEFT	CADRE LATÉRAL GAUCHE

Sæt gods på aksler 2430 x 55 cm cambrige, Giessgut auf wellen, Metal on shafts, Metal sur arbres

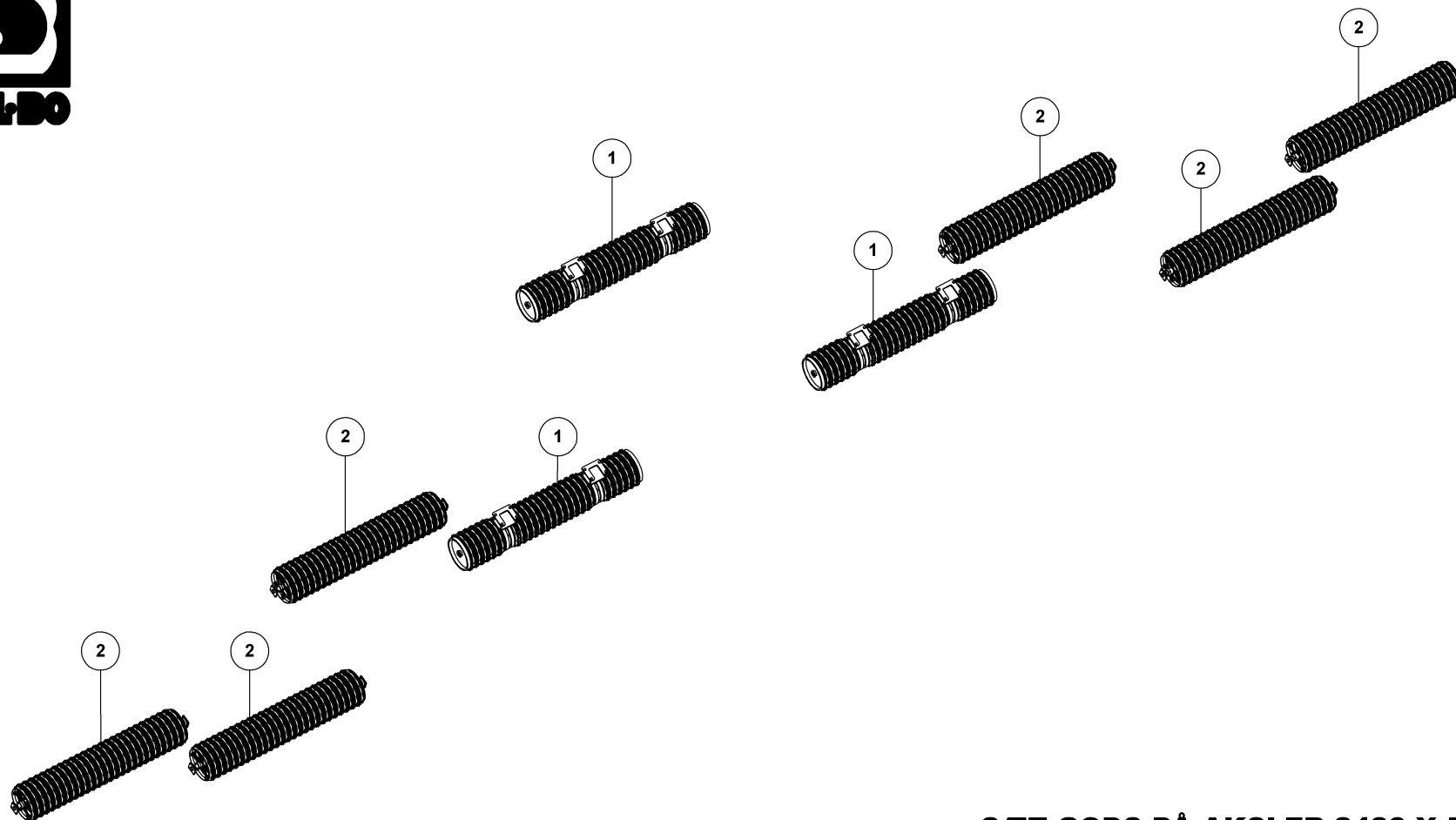

**SÆT GODS PÅ AKSLER 2430 X 55 CM
CAMBRIDGE SNOWFLAKE**

GISSGUT AUF WELLEN
METAL ON SHAFTS
MÉTAL SUR ARBRES

63199-7



SÆT GODS PÅ AKSLER 2430 X 55 CM CAMBRIDGE SNOWFLAKE

63199-7

GIESSGUT AUF WELLEN
METAL ON SHAFTS
MÉTAL SUR ARBRES

Pos.	Qty.	Part nr.	Benævnelse	Bezeichnung	Description	Designation
1	3	63221-7	GODS PÅ AKSEL 55 CM SNOWFLAKE	SATZ GIESSGUT FÜR DIE WELLEN	METAL SET FOR AXLE	MÉTAL SUR ARBRES
2	6	63222-7	GODS PÅ AKSEL 55 CM CAMBRIDGE L=2940	SATZ GIESSGUT FÜR DIE WELLEN	METAL SET FOR AXLE	MÉTAL SUR ARBRES

Gods på aksel 3 midterste aksler, Satz giessgut für die wellen, Metal set for axle, Metal sur arbres

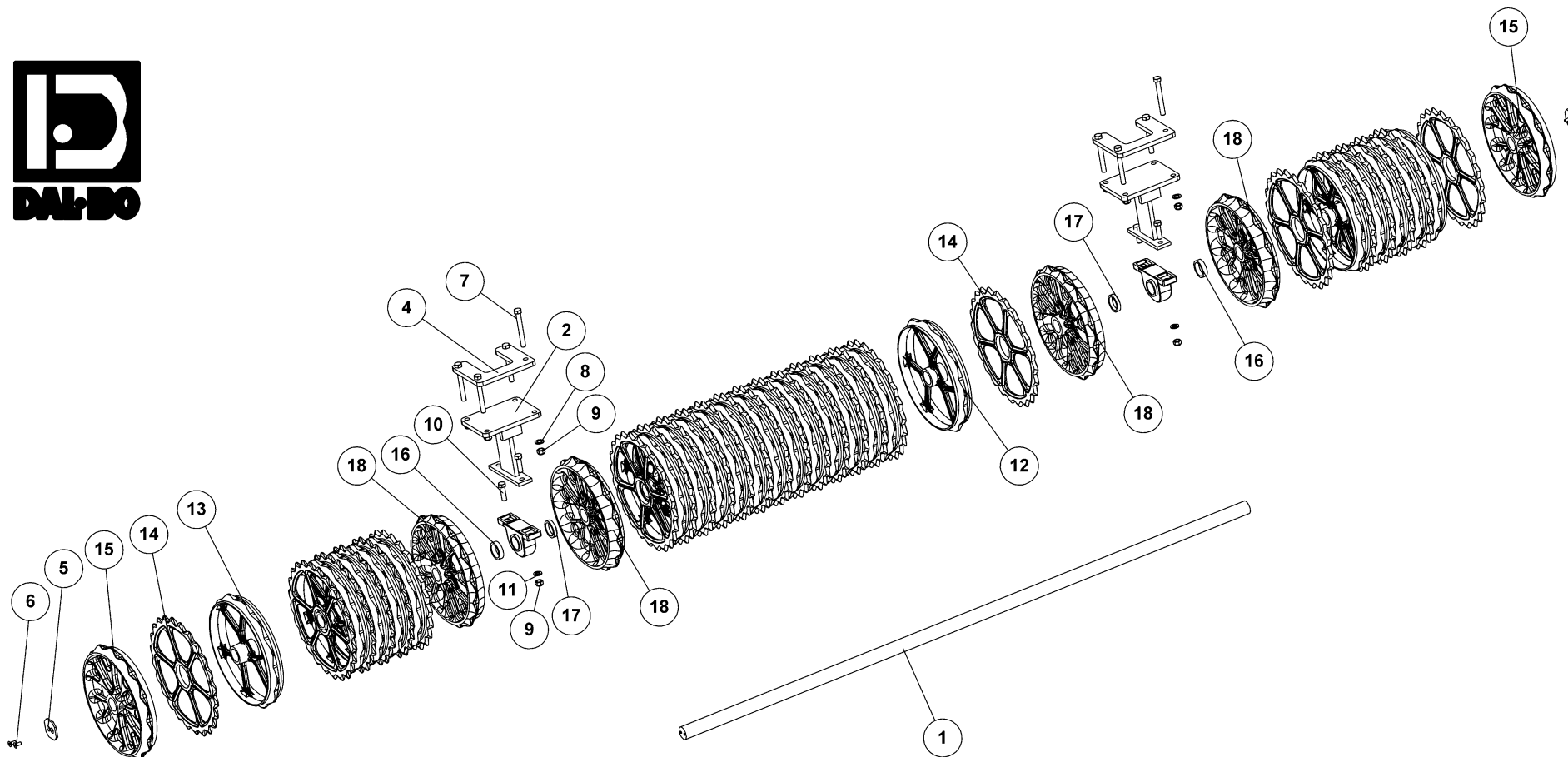

**GODS PÅ AKSEL 55 CM SNOWFLAKE
2430 - 3 MIDTERSTE AKSLER**

SATZ GIESSGUT FÜR DIE WELLEN
METAL SET FOR AXLE
MÉTAL SUR ARBRES

63221-7



GODS PÅ AKSEL 55 CM SNOWFLAKE 2430 - 3 MIDTERSTE AKSLER

63221-7

SATZ GIESSGUT FÜR DIE WELLEN
METAL SET FOR AXLE
MÉTAL SUR ARBRES

Pos.	Qty.	Part nr.	Benævnelse	Bezeichnung	Description	Designation
1	1	63587	AKSEL Ø60X2954 M/GEV. - MIDT	WELLE	SHAFT	ARBRE
2	2	33412	STØTTE FOR MIDTERLEJE	STÜTZE	SUPPORT	FIXATION
3	2	12459	KOMPLET STÅLEJE Ø60 MM - SKF SYJ65KF+H2313.	KOMPLETTES STEH LAGER	COMPLETE STEEL BEARING	PALIER COMPLET
4	2	33992	SPÆNDEPLADE - TOP	PLATTE	FASTENING PLATE	PLAQUE
5	2	90093	SKIVE TIL 60 MM AKSELENDE (80 MM NAV)	SCHEIBE	WASHER	RONDELLE
6	4	92417	BOLT 12 x 30 GALV 8.8 UNDERSÆNKET	SCHRAUBE	COUNTERSUNK SCREW	BOULON
7	8	92604	BOLT 20x170 8.8 GALV.	SCHRAUBE	SCREW	BOULON
8	8	90664	SPÆND. SKIVE Ø39 X Ø23 X 3	UNTERLEGSCHIEBE	SEALING WASHER	RONDELLE DE SERRAGE
9	12	92052	MØTRIK M20, SELVLÅS. GALV. KV. 8.8	MUTTER SELBSTGESICHERT	SELF-LOCKING NUT	ÉCROU DE SÉCURITÉ
10	4	92342	BOLT M20X70 MM 8.8 GALV.	SCHRAUBE	SCREW	BOULON
11	4	90805	SKIVE M20, Ø21X37X4 - HÆRDET	UNTERLEGSCHIEBE	WASHER	RONDELLE DE SERRAGE
12	1	95786	55 CM GLAT RING - SNOWFLAKE DUCTILE			
13	22	95784	55 CM GLAT RING - SNOWFLAKE DUCTILE			
14	26	95785	Ø55 CM TAKKET RING - SNOWFLAKE DUCTILE			
15	2	15788	55 CM GLAT ENDERING AFDREJET - SNOWFLAKE	GLATTER ENDRING	SMOOTH ENDRING	ANNEAU FIN LISSE
16	2	93130002090L90LX	AFSTANDSSTYKKE Ø80XØ63 L=20MM	ABSTANDSSTÜCK	SPACER	ENTRETOISE
17	2	93130001590L90LX	AFSTANDSSTYKKE Ø80XØ63 L=15MM	ABSTANDSSTÜCK	SPACER	ENTRETOISE
18	4	15789	55 CM GLAT MIDTERLEJERING - SNOWFLAKE			

Gods på aksel – sider, Satz giessgut für die wellen, Metal set for axle, Metal sur arbres

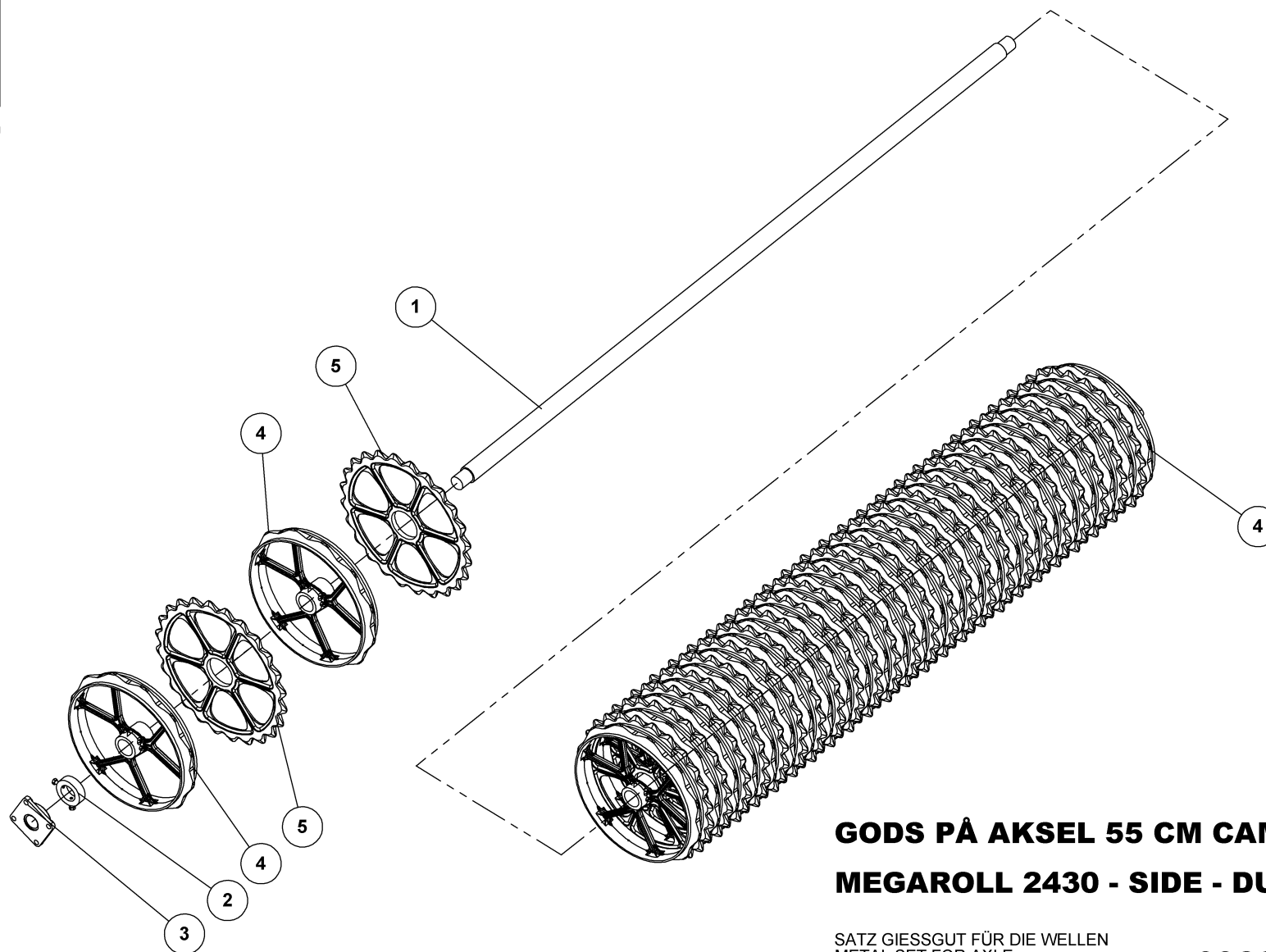

**GODS PÅ AKSEL 55 CM CAMBRIDGE L=2940
MEGAROLL 2430 - SIDE - DUCTILE**

SATZ GIESSGUT FÜR DIE WELLEN
METAL SET FOR AXLE
MÉTAL SUR ARBRES

63222-7



GODS PÅ AKSEL 55 CM CAMBRIDGE L=2940 MEGAROLL 2430 - SIDE - DUCTILE 63222-7

SATZ GIESSGUT FÜR DIE WELLEN
METAL SET FOR AXLE
MÉTAL SUR ARBRES

Pos.	Qty.	Part nr.	Benævnelse	Bezeichnung	Description	Designation
1	1	23386	AKSEL Ø60X2940	WELLE	SHAFT	ARBRE
2	2	12334	STOPRING Ø 60 KPL.	ANSCHLAGRING	STOP BUSHING	BAGUE D'ARRÊT
3	2	12437	FLANGELEJE Ø50 UCF 210 50 MFTRL	KOMPLETTES Y-LAGER	COMPLETE Y-BEARING	PALIER-Y COMPLET
4	27	95784	55 CM GLAT RING - SNOWFLAKE DUCTILE			
5	26	95785	Ø55 CM TAKKET RING - SNOWFLAKE DUCTILE			

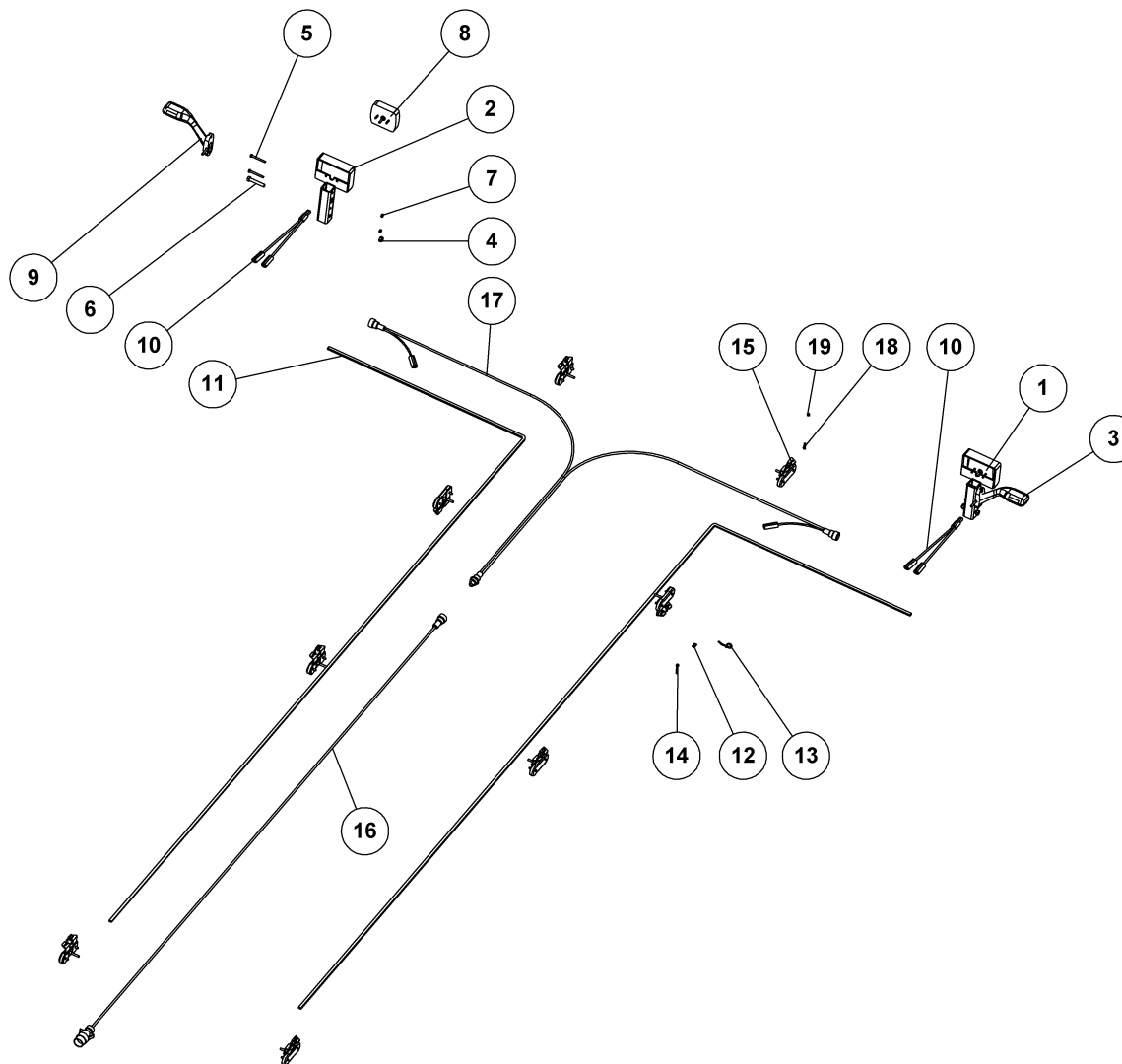

LYGTESÆT - LED
MEGAROLL

KABELSATZ
CABLE ASSEMBLY
ENSEMBLE DE CÂBLES

63310



LYGTESÆT - LED

KABELSATZ
CABLE ASSEMBLY
ENSEMBLE DE CÂBLES

MEGAROLL

63310

Pos.	Qty.	Part nr.	Benævnelse	Bezeichnung	Description	Designation
1	1	89706	BAGLYGTE - LED - VENSTRE MED NUMMERPLADELYS	RÜCKLICHT - BLINK/STOP/RÜCKLICHT	BACK LIGHTS - TURN/STOP/BACK	PHARE ARRIÈRE -CLIGNO./ARRÊT/PHARE ARRIÈRE
2	2	71454	LYGTESTANDER FÆLLES	LEUCHTSTÄNDER	LIGHT STAND	BÂTON DES LUMIÈRES
3	1	89715	MARKERINGSLYS VENSTRE - LED	LEUCHTE LINKS	MARKING LIGHTS, LEFT	LUMIÈRE DE SIGNALISATION GAUCHE
4	2	92049	MØTRIK M10, SELVLÅS, GALV. KV. 8.8	MUTTER	SELF-LOCKING NUT	ÉCROU
5	4	92253	BOLT M6X55, U/SKAF T GALV. KV. 8.8	SCHRAUBE	SCREW	BOULON
6	2	92277	BOLT M10X60, M/SKAF T GALV. KV. 8.8	SCHRAUBE	SCREW	BOULON
7	4	92027	MØTRIK M6 GALV. kl. 8	MUTTER	NUT	ÉCROU
8	1	89707	BAGLYGTE LED - HØJRE	RÜCKLICHT - BLINK/STOP/RÜCKLICHT	BACK LIGHTS - TURN/STOP/BACK	PHARE ARRIÈRE -CLIGNO./ARRÊT/PHARE ARRIÈRE
9	1	89716	MARKERINGSLYS HØJRE - LED	LEUCHTE RECHTS	MARKING LIGHTS, RIGHT	LUMIÈRE DE SIGNALISATION GAUCHE
10	2	89744	Y-KABEL FOR LED SLINGRELYGTE	KABELSATZ	CABLE ASSEMBLY	ENSEMBLE DE CÂBLES
11	2	89742	FLADKABEL 1X10M P&R PVC - LED	FLACHKABEL	FLAT CABLE	CÂBLE MÉPLAT
12	1	88146	KABELBØJLER 5 mm	KABELHALTER	CABLE BRACKET	COLLIER DE CÂBLE
13	1	89447	KABELBINDER 4,7 X 195 (STRIPS)	STRIPS	STRIPS	STRIPS
14	1	92386	PLADESKRUE PH Ø 4.8X40	SCHRAUBE	PLATE SCREW	VIS DE PLAQUE
15	8	89720	SIDEMARKERINGSLYS MVINKEL - LED	SEITENMARKIERUNGS LAMPE	SIDE MARKING LIGHT	LUMIÈRE DE SIGNALISATION LATÉRALE
16	1	89734	KABEL 1x12M - 7-POL STIK - LED	KABELSATZ	CABLE ASSEMBLY	ENSEMBLE DE CÂBLES
17	1	89735	FORLÆNGER/FORDELER KABEL 2x2,5M - LED	KABELSATZ	CABLE ASSEMBLY	ENSEMBLE DE CÂBLES
18	16	92238	BOLT M5X20, U/SKAF T GALV. KV. 8.8	SCHRAUBE	SCREW	BOULON
19	16	92026	MØTRIK M5, GALV. KV. 8.8	MUTTER	NUT	ÉCROU

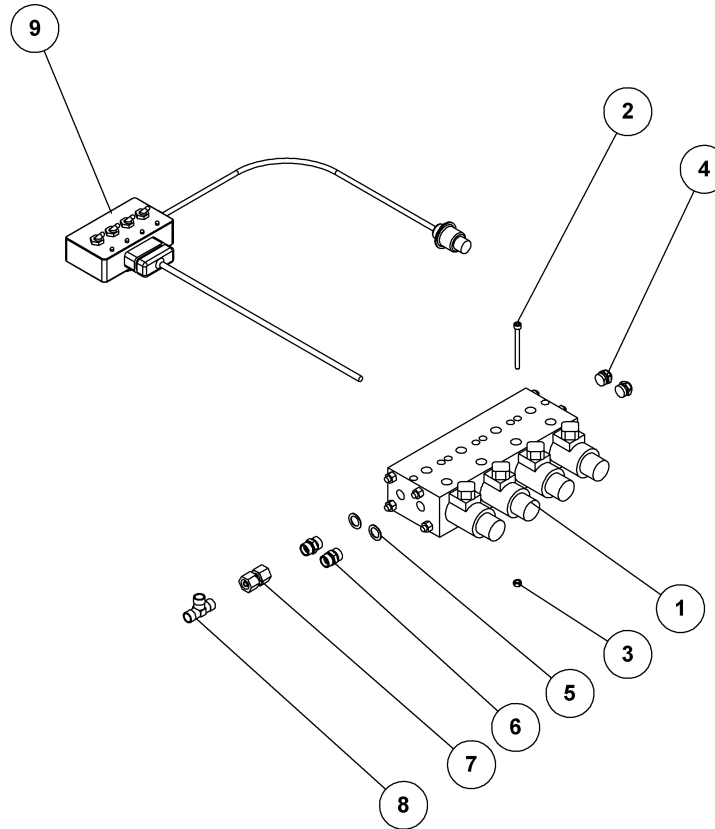

HYDRAULIK FOR EL-STYRING MEGAROLL

ELEKTR. HYDR. STEUERRING
EL.-HYDR. CONTROL (RING)
ANNEAU DE CONTRÔLE EL. HYDR.

63300



HYDRAULIK FOR EL-STYRING

MEGAROLL

63300

ELEKTR. HYDR. STEUERRING
 EL.-HYDR. CONTROL (RING)
 ANNEAU DE CONTRÔLE EL. HYDR.

Pos.	Qty.	Part nr.	Benævnelse	Bezeichnung	Description	Designation
1	1	90165	EL-VENTIL (MDF 4) MED SPOLER	KUGELHAHN	VALVE	VANETTE 3/8"
2	2	92244	BOLT M6 X70 UMBRACO	SCHRAUBE	SCREW	BOULON
3	2	92027	MØTRIK M6, GALV. KV. 8.8	MUTTER	NUT	ÉCROU
4	2	91093	SLUTPROP M/PAKNING 3/8"	SCHLUSSSTÖPSEL	END PLUG	BOUCHON DE FERMETURE
5	2	91028	3/8" BONDED SEALS PAKRING	BONDED SEALS PAKRING	BONDED SEAL WASHER	JOINT BONDED SEALS
6	2	91003	BRYSTNIPPEL M18 x 3/8" RG GALV.	VERSCHRAUBUNG	HEXAGON NIPPLE CONNECTOR	RACCORD DE JONCTIONS MÂLES
7	1	91025	RØRSTUDS M/2 OML.Ø 12-L M/O	GERADE VERSCHRAUBUNG	STRAIGHT CONNECTION	JOINT DROIT
8	1	91006	T-STYKKE M18X1.5 P-TV 12L	T-STÜCK	T-PIECE	T-PIÈCE
9	1	90166	ELSTYRINGS BOX MED 4 KONTAKTER	ELEKTR. HYDR. STEUERRING	EL.-HYDR. CONTROL (RING)	ANNEAU DE CONTRÔLE EL. HYDR.

Hydraulisk affjedring, Hydraulischem steinausloser, Hydr. stone safety release, Dispositif de relache de pierre hydr.

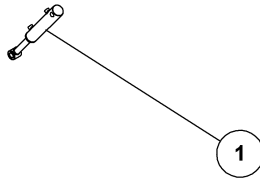

HYDRAULISK AFFJEDRING TROMLESEKTIONER MEGAROLL

MIT HYDRAULISCHEM STEINAUSLÖSER
WITH HYDR. STONE SAFETLY RELEASE
DISPOSITIF DE RELACHE DE PIERRE HYDR. **63301**



HYDRAULISK AFFJEDRING TROMLESEKTIONER

MEGAROLL

63301

MIT HYDRAULISCHEM STEINAUSLÖSER
WITH HYDR. STONE SAFETLY RELEASE
DISPOSITIF DE RELÂCHE DE PIERRE HYDR.

Pos.	Qty.	Part nr.	Benævnelse	Bezeichnung	Description	Designation
1	5	91840	CYLINDER 50/30/150 ø25 L=350	ZYLINDER	CYLINDER	VERRIN

Hydr. hydraulisk støtteben, Stutfuss, Jack, Bequille

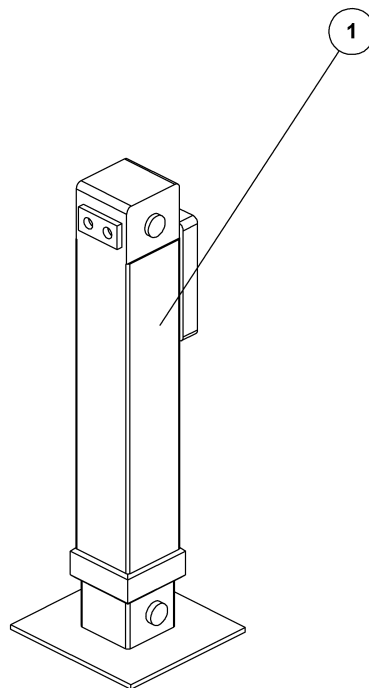

**HYDR. HYDRAULISK STØTTEBEN
MEGAROLL**

STÜTZFUSS
JACK
BÉQUILLE

63302



HYDR. HYDRAULISK STØTTEBEN

MEGAROLL

63302

STÜTZFUSS
JACK
BÉQUILLE

Pos.	Qty.	Part nr.	Benævnelse	Bezeichnung	Description	Designation
1	1	63226	STØTTEBEN HYDR. - 2430	STÜTZFUSS	JACK	BÉQUILLE

Vippecyliner, Klippzylinder, Tilting cylinder, verrin de basculement

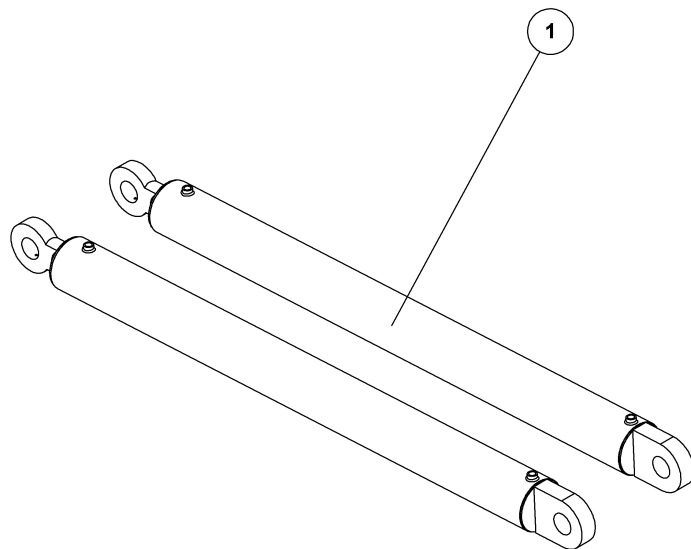

VIPPECYLINDER
MEGAROLL

KIPPZYLINDER
TILTING CYLINDER
VERRIN DE BASCULEMENT

63303



VIPPECYLINDER

KIPPZYLINDER
TILTING CYLINDER
VERRIN DE BASCULEMENT

MEGAROLL

63303

Pos.	Qty.	Part nr.	Benævnelse	Bezeichnung	Description	Designation
1	2	91882	CYLINDER 150/100X1800	ZYLINDER	RAN	VERRIN

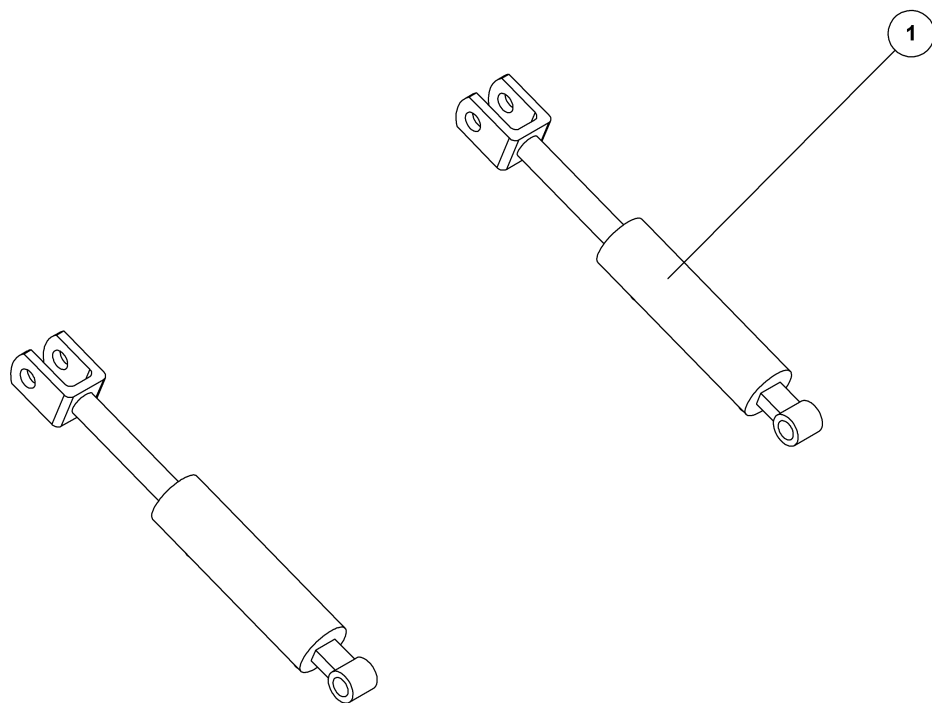

**HYDR. LØFT/ SÆNK BAGERSTE TROMLESEKTION
MEGAROLL**

HYDRAULIK TIEFENREGULIERUNG
HYDRAULIC DEPTH ADJUSTMENT
HYDRAULIQUE RÉGLAGE DE PROFOND

63304



HYDR. LØFT/ SÆNK BAGERSTE TROMLESEKTION

MEGAROLL

63304

HYDRAULIK TIEFENREGULIERUNG
HYDRAULIC DEPTH ADJUSTMENT
HYDRAULIQUE RÉGLAGE DE PROFOND

Pos.	Qty.	Part nr.	Benævnelse	Bezeichnung	Description	Designation
1	2	78275	CYLINDER 80X40X180 M. GAFFEL			

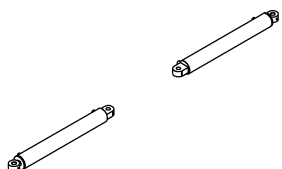
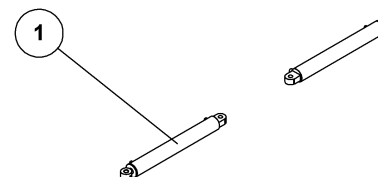

HYDR. UDKLAP YDERSTE SEKTIONER MEGAROLL

HYDRAULIK
HYDRAULIC
HYDRAULIQUE

63305



HYDR. UDKLAP YDERSTE SEKTIONER

MEGAROLL

63305

HYDRAULIK
HYDRAULIC
HYDRAULIQUE

Pos.	Qty.	Part nr.	Benævnelse	Bezeichnung	Description	Designation
1	4	91895	CYLINDER 90/40X700	ZYLINDER	CYLINDER	CYLINDRE

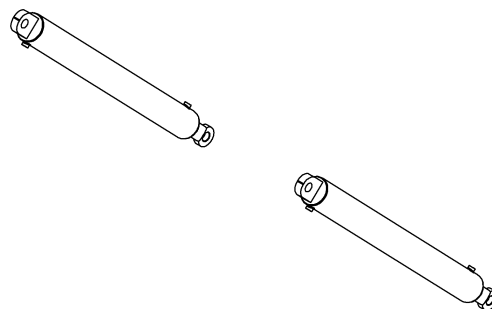
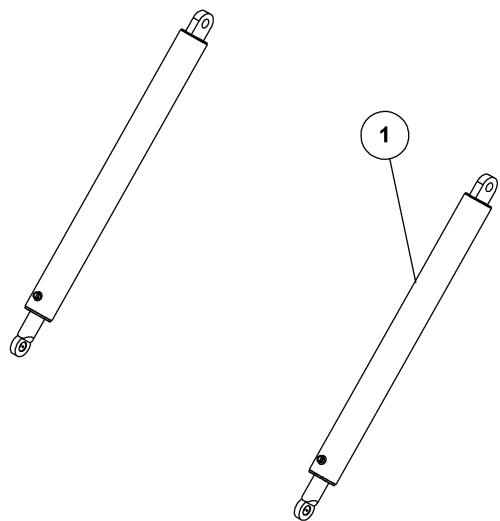

HYDR. UDKLAP OG VÆGTFORDELING SIDER MEGAROLL

HYDRAULIK
HYDRAULIC
HYDRAULIQUE

63306



HYDR. UDKLAP OG VÆGTFORDELING SIDER

MEGAROLL

63306

HYDRAULIK
HYDRAULIC
HYDRAULIQUE

Pos.	Qty.	Part nr.	Benævnelse	Bezeichnung	Description	Designation
1	4	91867	CYLINDER 110/70X1215	ZYLINDER	RAN	VERRIN

Hydr. vægtoverføring yderst, Hydraulik, Hydraulic, Hydraulique

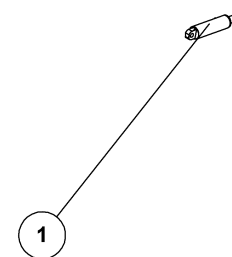

HYDR. VÆGTFORDELING YDERST MEGAROLL

HYDRAULIK
HYDRAULIC
HYDRAULIQUE

63307



HYDR. VÆGTFORDELING YDERST

MEGAROLL

63307

HYDRAULIK
HYDRAULIC
HYDRAULIQUE

Pos.	Qty.	Part nr.	Benævnelse	Bezeichnung	Description	Designation
1	2	48340	CYLINDER 526-AD-80/50X205-A			